

K-TRONIC

Typenreihe
Série
Série

K 200 / K 400
K 200 / K 400
K 200 / K 400



Ersatzteilliste Spare parts list Liste de pièces détachées



ERSATZTEILLISTE



SPARE PARTS LIST

LISTE DE PIECES DETACHEES

Typenreihe	K 200 / K 400	gültig ab	06 / 2001
Type	K 200 / K 400	valid from	06 / 2001
Série	K 200 / K 400	valable à partir de	06 / 2001

*Bei Ersatzteilbestellung sind folgende Angaben erforderlich:
Following information should be stated in your spare parts orders:
Veuillez indiquer s.v.p. les informations suivantes dans vos commandes.*

Kunde/Betreff:
Customer/Ref.: _____
Client/Objet:

MEIKO-Auftragsnummer
MEIKO-Serial No.: _____
No. de série MEIKO:

Maschinentype:
Type of machine: _____
Type de la machine:

Positions-Nr.:
Item No.: _____
Repère No.:

Benennung:
Denomination: _____
Dénomination:

Ersatzteilnummer:
Part No.: _____
Pièce No.:

Bei einigen Teilen sind zusätzliche Angaben nötig. Diese Teile sind in der Ersatzteilliste mit einem entsprechenden Hinweis versehen.

Some parts require more detailed information, these parts are especially stated in our list.

Il faut donner des informations supplémentaires pour quelques pièces.
Nous les avons munies de remarques spéciales.

Kennzeichnung der Ersatzteile:

* / V Diese Teile empfehlen wir auf Lager zu legen!

V = Verschleißteil!

Special marks of spares:

* / V We recommend to store these parts!

V = wear and tare part!

Marquage speciales des pieces:

* / V Nous recommandons de prendre ces pièces en stock!

V = pièce d'usure!

ERSATZTEILLISTE



SPARE PARTS LIST

LISTE DE PIECES DETACHEES

Auf nachfolgenden Ersatzteilblättern finden Sie einige Bauteile (Pumpen, Spulen, Motoren, Schalter und Heizungen), die nicht mit Ident Nummern angezogen sind. Die dazugehörigen Id. Nummern finden Sie in der Stückliste des Elektroschaltplanes.

Aufschlüsselung des Anhanges zur Ident Nr:

01 = Arbeitsrichtung Links-Rechts
02 = Arbeitsrichtung Rechts-Links
03 = Ausführung Links
04 = Ausführung Rechts
L-R = Arbeitsrichtung Links-Rechts
R-L = Arbeitsrichtung Rechts-Links

On the enclosed spare parts sheets you can find some construction parts (pumps, coils, motors, switches and heatings) which do not have an identification number. The corresponding ident numbers can be found in the parts list of the wiring diagram

Details of the enclosure:

01 = working direction left-right
02 = working direction right-left
03 = execution left
04 = execution right
L-R = working direction left-right
R-L = working direction right-left

Sur les fiches des pièces détachées en annexe vous trouverez quelques pièces de construction (pompes, bobines, moteurs, interrupteurs, chauffages) sans numéro d'identification. Vous trouverez les numéros correspondants dans la liste de pièces du schéma de connexions.

Détails de l'annexe du numéro d'identification:

01 = sens de travail gauche-droite
02 = sens de travail droite-gauche
03 = exécution gauche
04 = exécution droite
L-R = sens de travail gauche-droite
R-L = sens de travail droite-gauche

ERSATZTEILLISTE



SPARE PARTS LIST

LISTE DE PIECES DETACHEES

INHALTSVERZEICHNIS	CONTENTS	SOMMAIRE	SEITE PAGE
E 250 (EINLAUF 250MM)	E 250 (FEEDING TUNNEL 250MM)	E 250 (TUNNEL D' ENTREE 250MM)	10
KV 600 (KLEINE VORABRÄUMUNG 600MM)	KV 600 (COMPACT PRE-WASH ZONE 600MM)	KV 600 (ZONE DE PRELAVAGE COMPACTE 600MM)	11
CSS 750 (CHEMIESPARSYSTEMZONE 750MM)	CSS 750 (CSS ZONE 750MM)	CSS 750 (ZONE CSS 750MM)	12
V 750 (VORABRÄUMUNG 750MM)	V 750 (PRE-WASH ZONE 750MM)	V750 (ZONE DE PRELAVAGE 750MM)	13
VA 800 (VORABRÄUMUNG 800MM)	VA 800 (PRE-WASH ZONE 800MM)	VA 800 (ZONE DE PRELAVAGE 800MM)	14
VA 1200 (VORABRÄUMUNG 1200MM)	VA 1200 (PRE-WASH ZONE 1200MM)	VA 1200 (ZONE DE PRELAVAGE 1200MM)	15
HWZ I 800 (HAUPTWASCHZONE I 800MM)	HWZ I 800 (WASH ZONE I 800MM)	HWZ I 800 (ZONE DE LAVAGE I 800MM)	16
HWZ II 800 (HAUPTWASCHZONE II 800MM)	HWZ II 800 (WASH ZONE II 800MM)	HWZ II 800 (ZONE DE LAVAGE II 800MM)	17
HWZ II-P 1200 (HAUPTWASCHZONE II MIT PUMPENKLARSPÜLUNG 1200MM)	HWZ II-P 1200 (WASH ZONE II WITH PUMP RINSE 1200MM)	HWZ II-P 1200 (ZONE DE LAVAGE II AVEC RINCAGE A POMPE 1200MM)	18
F 500 (FRISCHWASSER-KLARSPÜLZONE 500MM)	F 500 (FRESH WATER FINAL RINSE ZONE 500MM)	F 500 (ZONE DE RINCAGE FINAL 500MM)	19
F + DEMI 500 (FRISCHWASSER- KLARSPÜLZONE MIT DEMIKLARSPÜLUNG 500MM)	F + DEMI 500 (FRESH WATER FINAL RINSE ZONE WITH DEMI. RINSING 500MM)	F + DEMI 500 (ZONE DE RINCAGE FINAL AVEC RINCAGE EAU DEMI 500MM)	20
F + PI 500 (FRISCHWASSER- KLARSPÜLZONE MIT INTEGRIERTER PUMPENKLARSPÜLUNG 500MM)	F + PI 500 (FRESH WATER FINAL RINSE ZONE WITH INTEGRATED PUMP RINSE 500MM)	F + PI 500 (ZONE DE RINCAGE FINAL AVEC RINCAGE A POMPE INTEGRE 500MM)	21
SPRITZSCHUTZTUNNEL	FEEDING TUNNEL	SAS DE ENTREE	22
TROCKNUNG	DRYING	SECHAGE	23

INHALTSVERZEICHNIS		CONTENTS	SOMMAIRE	SEITE PAGE
1.0	KORBTRANSPORT	BASKET TRANSPORT	TRANSPORT DE CASIERS	24
2.0	VORHANG	CURTAIN	RIDEAU	
2.1	VORHANG 650X480	CURTAIN 650X480	RIDEAU 650X480	26
2.2	VORHANG 650X400	CURTAIN 650X400	RIDEAU 650X400	27
2.3	VORHANG 610X480	CURTAIN 610X480	RIDEAU 610X480	28
2.4	VORHANG TROCKNUNG	CURTAIN DRYING	RIDEAU SECHAGE	29
3.0	WASCHSYSTEM	WASH SYSTEM	SYSTEME DE LAVAGE	
3.1	WASCHSYSTEM-KV	WASH SYSTEM-KV	SYSTEME DE LAVAGE-KV	30
3.2	WASCHSYSTEM-CSS 750 / V750	WASH SYSTEM-CSS 750 / V750	SYSTEME DE LAVAGE-CSS	31
3.2.1	WASCHSYSTEM-CSS TOP	WASH SYSTEM-CSS TOP	SYSTEME DE LAVAGE-CSS TOP	32
3.4.1	WASCHSYSTEM-VA/HWZ	WASH SYSTEM- VA/HWZ	SYSTEME DE LAVAGE- VA/HWZ	34
3.4.2	WASCHSYSTEM-VA/HWZ	WASH SYSTEM- VA/HWZ	SYSTEME DE LAVAGE- VA/HWZ	36
3.5	PUMPENKLARSPÜLUNG	PUMP FINAL RINSE	RINCAGE FINAL A POMPE	38
3.6.1	FRISCHWASSERKLARSPÜLUNG	FRESH WATER FINAL RINSE	RINCAGE FINAL A L'EAU CLAIRE	39
3.7	DEMI-KLARSPÜLUNG	FINAL RINSE-DEMI	RINCAGE FINAL-DEMI	40
3.8	KLARSPÜLUNG-PI	FINAL RINSE-PI	RINCAGE FINAL-PI	41
4.0	TANKABDECKSIEB	TANK COVERING SIEVE	TAMIS DE RECOUVEREMENT DE BAC	
4.1	TANKABDECKSIEB-KV	TANK COVERING SIEVE-KV	TAMIS DE RECOUVR. DE BAC-KV	42
4.2	TANKABDECKSIEB-CSS	TANK COVERING SIEVE-CSS	TAMIS DE RECOUVR. DE BAC-CSS	43
4.3	TANKABDECKSIEB	TANK COVERING SIEVE	TAMIS DE RECOUVR. DE BAC	44
4.4	TANKABDECKSIEB	TANK COVERING SIEVE	TAMIS DE RECOUVR. DE BAC	45
4.5	TANKABDECKSIEB	TANK COVERING SIEVE	TAMIS DE RECOUVR. DE BAC	46
5.0	TANKABLAUF	DRAIN	VIDANGE	
5.1	TANKABLAUF-KV	DRAIN-KV	VIDANGE-KV	47
5.2	TANKABLAUF-CSS	DRAIN-CSS	VIDANGE-CSS	48
5.3	TANKABLAUF	DRAIN	VIDANGE	49
5.4	TANKABLAUF	DRAIN	VIDANGE	51
6.0	WASCHPUMPE	WASH PUMP	POMPE DE LAVAGE	
6.1	WASCHPUMPE-KV	WASH PUMP-KV	POMPE DE LAVAGE-KV	52
6.2	WASCHPUMPE-CSS	WASH PUMP-CSS	POMPE DE LAVAGE-CSS	54
6.4	WASCHPUMPE 1,7KW	WASH PUMP 1,7KW	POMPE DE LAVAGE 1,7KW	56
6.5	WASCHPUMPE	WASH PUMP	POMPE DE LAVAGE	58
6.6	WASCHPUMPE	WASH PUMP	POMPE DE LAVAGE	60
7.0	TROCKNUNG	DRYING	SECHAGE	63

ERSATZTEILLISTE



SPARE PARTS LIST

Liste de pièces détachées

INHALTSVERZEICHNIS		CONTENTS	SOMMAIRE	SEITE PAGE
8.0	TÜR	DOOR	PORTE	
8.1	TÜR 500	DOOR 500	PORTE 500	64
8.2	TÜR 800	DOOR 800	PORTE 800	66
8.3	TÜR 1200	DOOR 1200	PORTE 1200	78
9.0	FRISCHWASSERINSTALLATION	FRESH WATER INSTALLATION	INSTALLATION A EAU CLAIRE	70
9.1	FRISCHWASSERNETZTRENNUNG	FRESH WATER MAINS ISOLATING DEVICE	DISPOSITIF DE ISOLEMENT DU RESEAU DE EAU	74
9.2	FILTER	FILTER	FILTRE	76
9.3	DRUCKMINDERVENTIL	PRESSURE REDUCING VALVE	REDUCTEUR DE PRESSION	77
9.4	MAGNETVENTIL	SOLENOID VALVE	ELECTROVANNE	78
9.5	DURCHFLUSSMESSER	FLOW CONTROL	DEBIT METRE	80
9.6	ÜBERDRUCKVENTIL	OVERPRESSURE VALVE	SOUPAPE DE SURPRESSION	81
9.7	NETZMITTELMISCHBEHÄLTER	RINSE-AID MIXING CHAMBER	RESERVOIR DE MELANGE DE PRODUIT DE RINCAGE	82
9.8	WÄRMETAUSCHER	HEAT EXCHANGER	EXCHANGEUR DE CHALEUR	83
9.9	ABSPERRSCHIEBER	STOP BAFFLE	CLAPET DE ARRET	84
9.10	MENGENREGLER	FLOW REGULATOR	REGULATEUR DE DEBIT	85
10.0	HEIZUNG	HEATING	CHAUFFAGE	
10.1	ELEKTROBEHEIZUNG	ELECTRICAL HEATING	CAUFFAGE ELECTRIQUE	87
10.1.1	TANKHEIZUNG ELEKTRISCH	TANK HEATING ELEMENT ELECTR.	RESISTANCE DU BAC ELECTR.	88
10.1.2	BOILER	BOILER	SURCHAFFEUR	90
10.1.3.1	BOILER	BOILER	SURCHAFFEUR	92
10.1.4	TROCKNUNGSHEIZREGISTER	DRYING-HEATING REGISTER	REGISTRE DE CHAUFF.-SECHAGE	94
11.0	TAKTSCHALTER	INTERVAL SWITCH	INT. DE SYNCHRONISATION	96
12.0	FRISCHWASSERSPARSCHALTER	FRESH WATER SAVING DEVICE	INT. ECONOMISEUR EAU DE RINCAGE	97
15.0	ZUBEHÖR	ACCESSORIES	ACCESSOIRES	
15.1.2	MASCHINENSTOLLEN	FEET OF MACHINE	PIEDS DE MACHINE	98
15.1.3	ROHRABDICHTUNG	TUBE PACKING	JOINT DE TUYAU	99
15.1.4	SCHWIMMERSCHALTER	FLOATING SWITCH	FLOTTEUR P. NIVEAU DE BAC	100
15.1.5	TISCHENDSCHALTER	TABLE END SWITCH	INTERRUPTEUR FIN DE COURSE	101
15.2.1.1	TANKABLAUF	DRAIN	VIDANGE	102
15.2.2	ABSAUGGEBLÄSE	EXTRACTION FAN	VENTILATEUR D'ASPIRATION	104
15.2.3	ABSAUGGEBLÄSE	EXTRACTION FAN	VENTILATEUR D'ASPIRATION	105
15.2.4	RADIALGEBLÄSE	RADIAL FAN	VENTILATEUR RADIAL	106
15.2.5	FROSTSCHUTZWÄCHTER	ANTI-FREEZE PROTECTION	PROTECTEUR ANTI-GEL	107
15.2.6	SCHWIMMERSCHALTER	FLOATING SWITCH	FLOTTEUR P. NIVEAU DE BAC	108
16.1	KURVE 90°	CURVE 90°	COURBE 90°	109
16.2	KURVE 180°	CURVE 180°	COURBE 180°	111

ERSATZTEILLISTE



SPARE PARTS LIST

LISTE DE PIECES DETACHEES

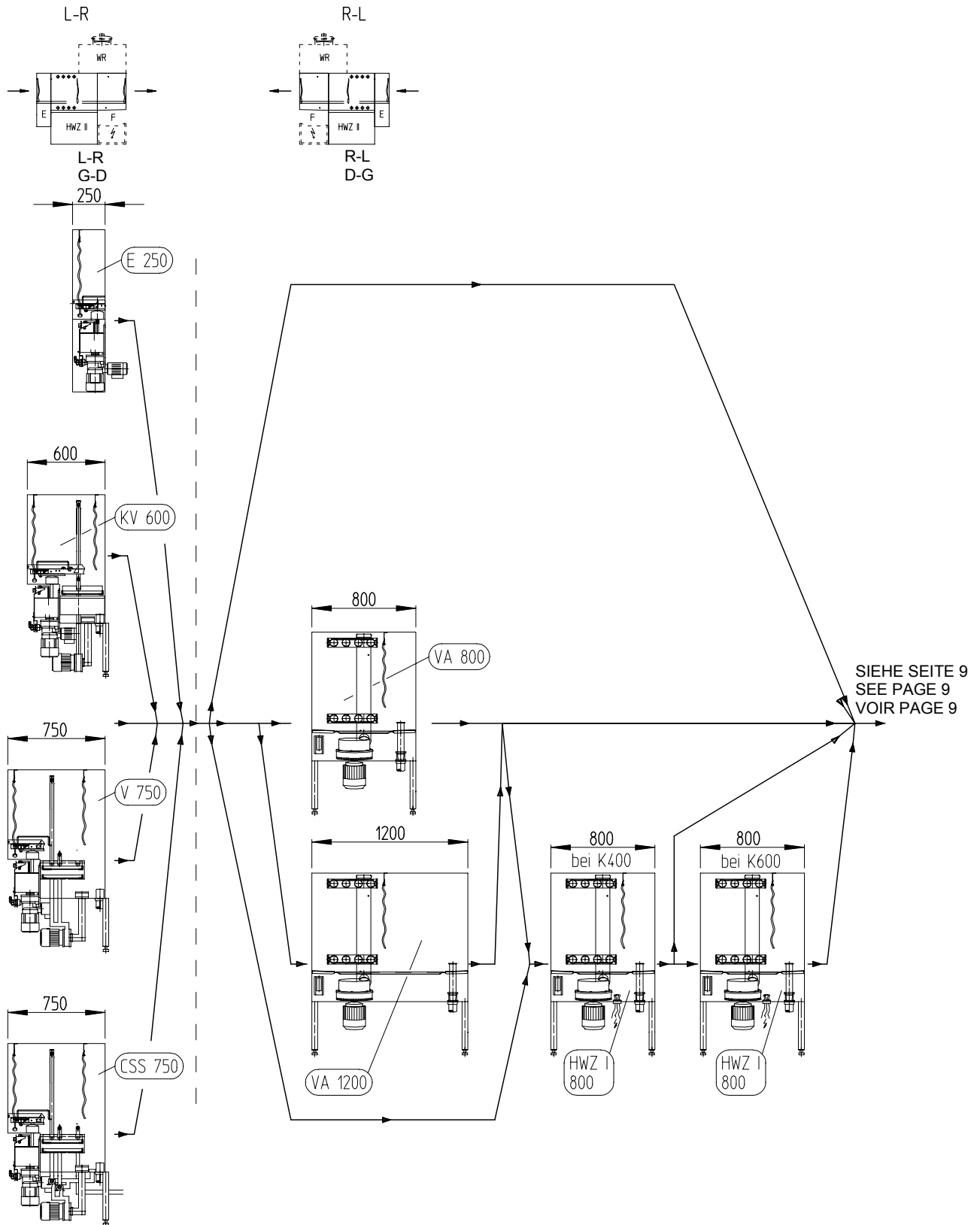

ERSATZTEILLISTE

SPARE PARTS LIST

LISTE DE PIECES DETACHEES

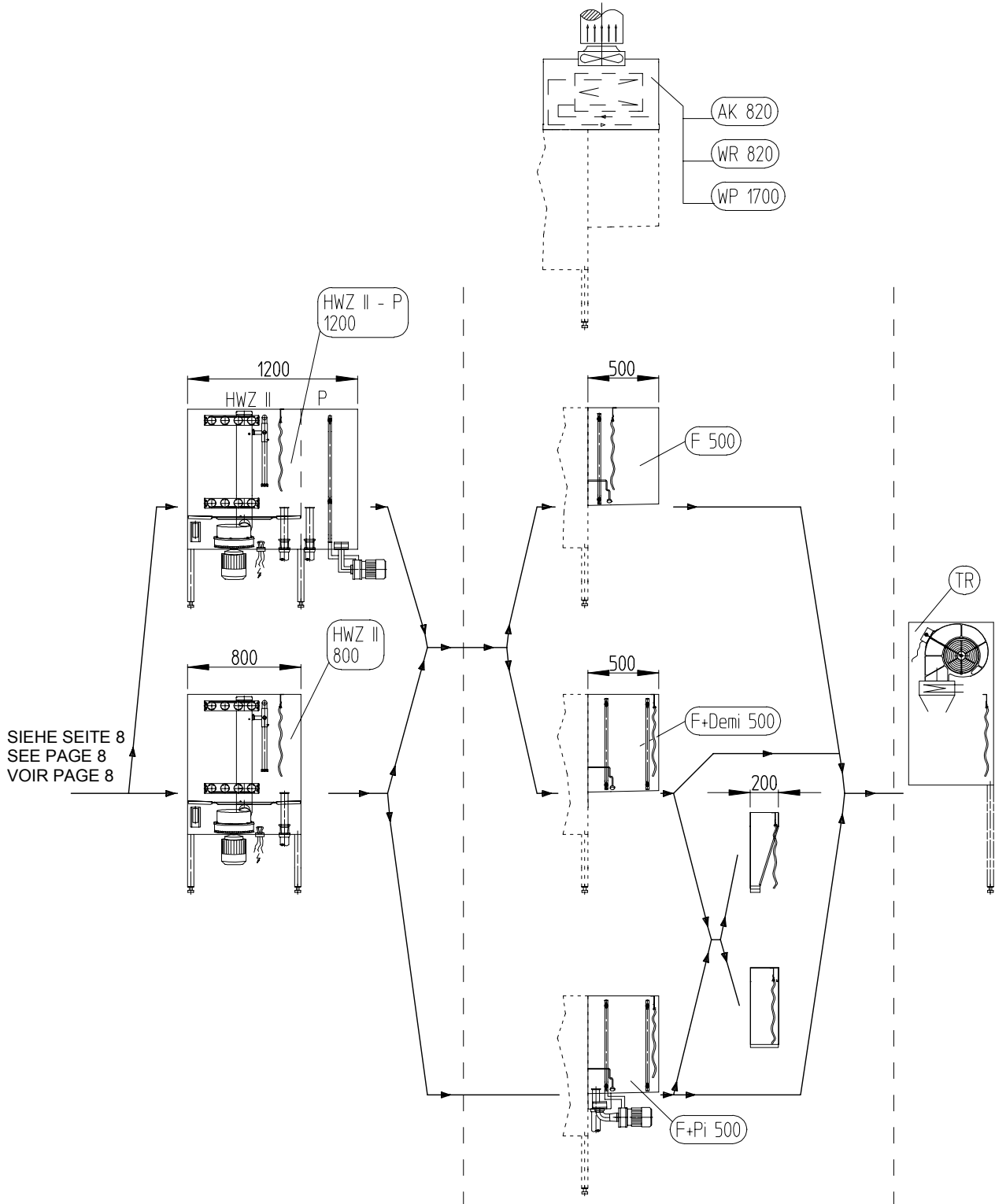

E 250 (EINLAUF 250MM)



E 250 (FEEDING TUNNEL 250MM)

E 250 (TUNNEL D'ENTREE 250MM)

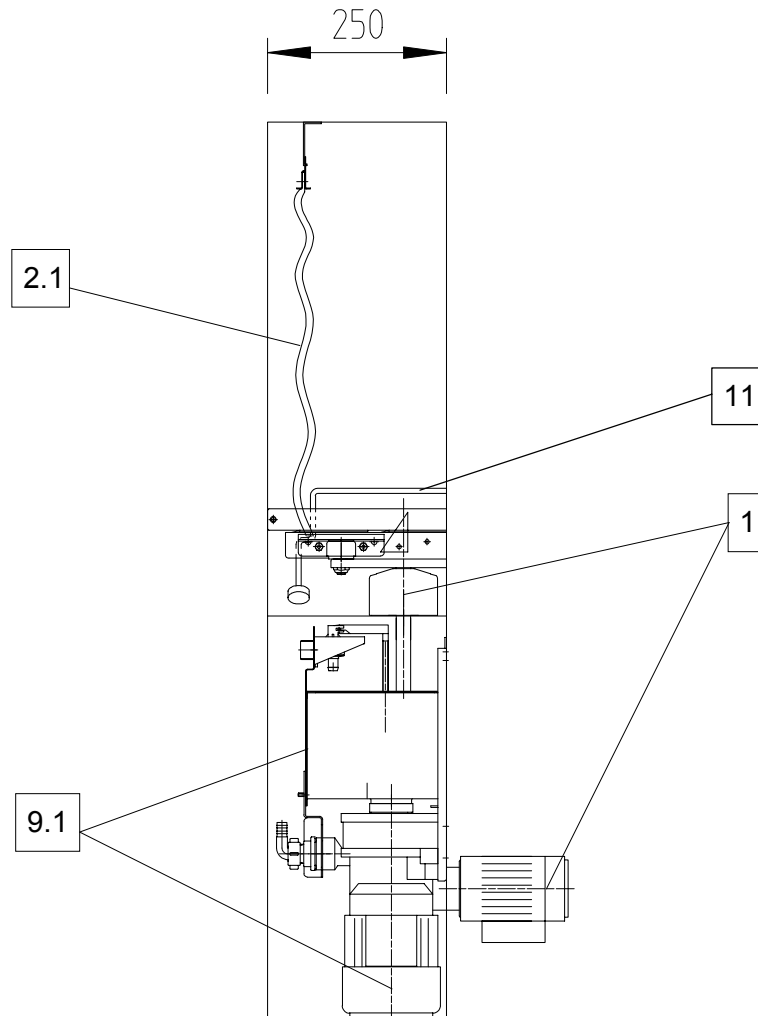

POS.	BEZEICHNUNG	DESIGNATION	DESIGNATION
1	ANTRIEB	DRIVE	ENTRAINEMENT
2.1	VORHANG 650X480	CURTAIN 650X480	RIDEAU 650X480
9.1	FRISCHWASSERNETZTRENNUNG	FRESH WATER MAINS ISOLATING DEVICE	DISPOSITIF DE ISOLEMENT DU RESEAU DE EAU
11	TAKTSCHALTER	INTERVAL SWITCH	INTERRUPTEUR DE SYNCHRONISATION

KV 600 (KLEINE VORABRÄUMUNG 600MM)



KV 600 (COMPACT PRE-WASH ZONE 600MM)

KV 600 (ZONE DE PRELAVAGE COMPACTE 600MM)

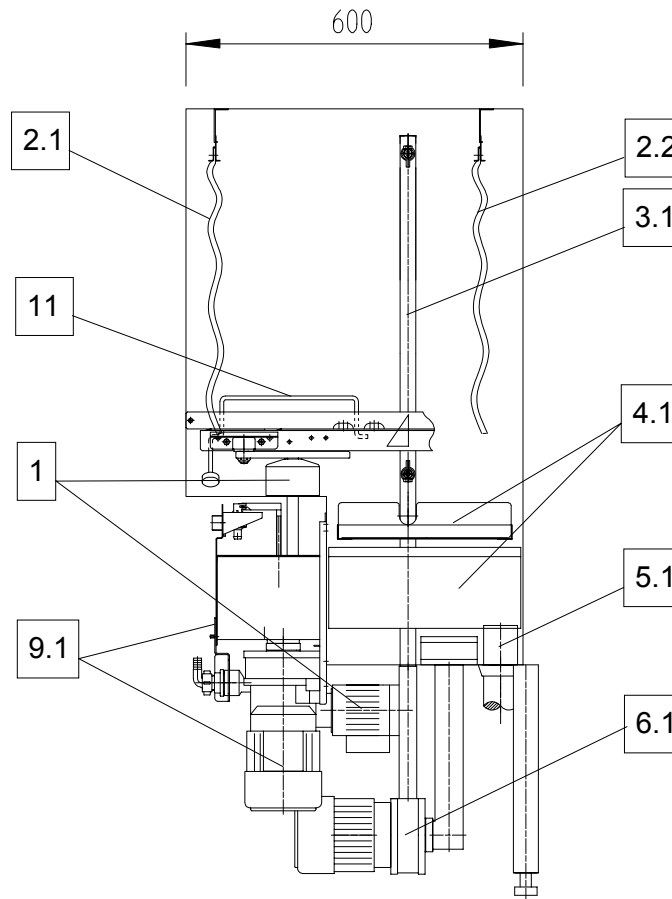

POS.	BEZEICHNUNG	DESIGNATION	DESIGNATION
1	ANTRIEB	DRIVE	ENTRAINEMENT
2.1	VORHANG 650X400	CURTAIN 650X400	RIDEAU 650X400
2.2	VORHANG 650X480	CURTAIN 650X480	RIDEAU 650X480
3.1	WASCHSYSTEM-KV	WASH SYSTEM-KV	SYSTEME DE LAVAGE-KV
4.1	SIEB-KV	SIEVE-KV	TAMIS-KV
5.1	ABLAUF	DRAIN	VIDANGE
6.1	WASCHPUMPE-KV	WASH PUMP-KV	POMPE DE LAVAGE-KV
9.1	FRISCHWASSERNETZTRENNUNG	FRESH WATER MAINS ISOLATING DEVICE	DISPOSITIF DE ISOLEMENT DU RESEAU DE EAU
11	TAKTSCHALTER	INTERVAL SWITCH	INTERRUPTEUR DE SYNCHRONISATION

CSS 750 (CHEMIESPARSYSTEMZONE 750MM)



CSS 750 (CSS ZONE 750MM)

CSS 750 (ZONE CSS 750MM)

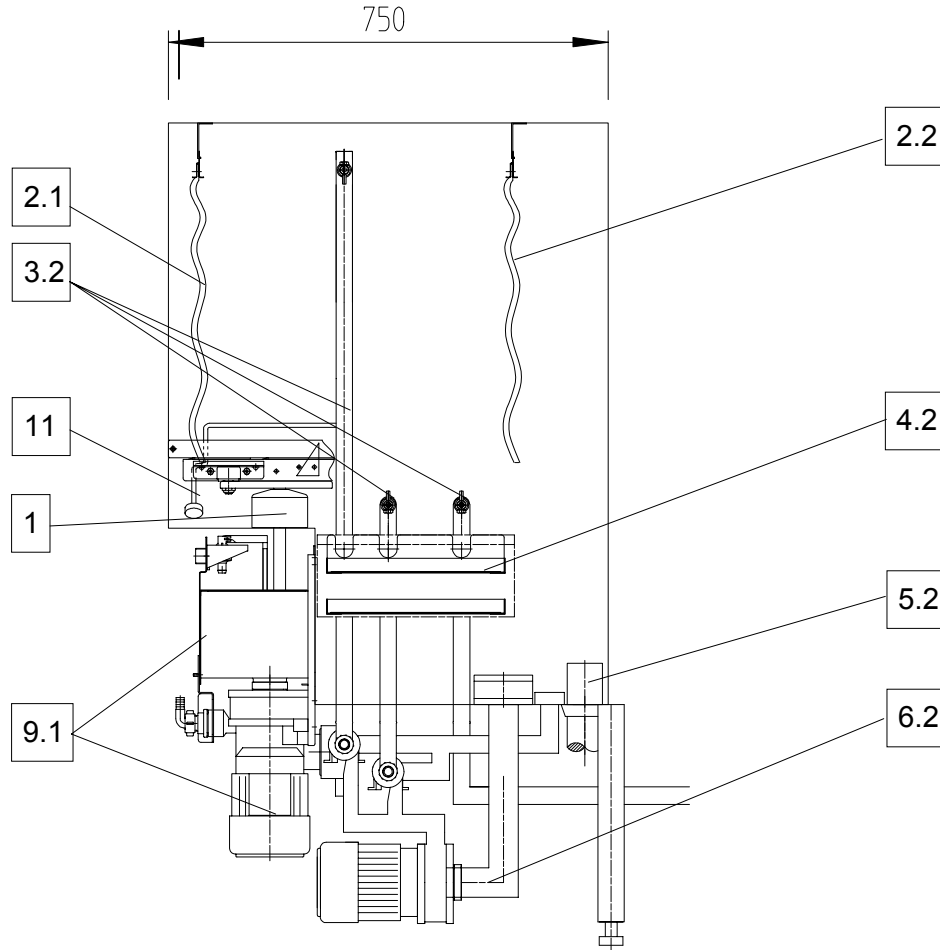

POS.	BEZEICHNUNG	DESIGNATION	DESIGNATION
------	-------------	-------------	-------------

1	ANTRIEBE	DRIVE	ENTRAINEMENT
2.1	VORHANG 650X480	CURTAIN 650X480	RIDEAU 650X480
2.2	VORHANG 650X400	CURTAIN 650X400	RIDEAU 650X400
3.2	WASCHSYSTEM-CSS	WASH SYSTEM-CSS	SYSTEME DE LAVAGE-CSS
4.2	SIEB-CSS	SIEVE-CSS	TAMIS-CSS
5.2	ABLAUF	DRAIN	VIDANGE
6.2	WASCHPUMPE-CSS	WASH PUMP-CSS	POMPE DE LAVAGE-CSS
9.1	FRISCHWASSERNETZTRENNUNG	FRESH WATER MAINS ISOLATING DEVICE	DISPOSITIF DE ISOLEMENT DU RESEAU DE EAU
11	TAKTSCHALTER	INTERVAL SWITCH	INTERRUPTEUR DE SYNCHRONISATION

V 750 (VORABRÄUMUNG 750MM)



V 750 (PRE-WASH ZONE 750MM)

V750 (ZONE DE PRELAVAGE 750MM)

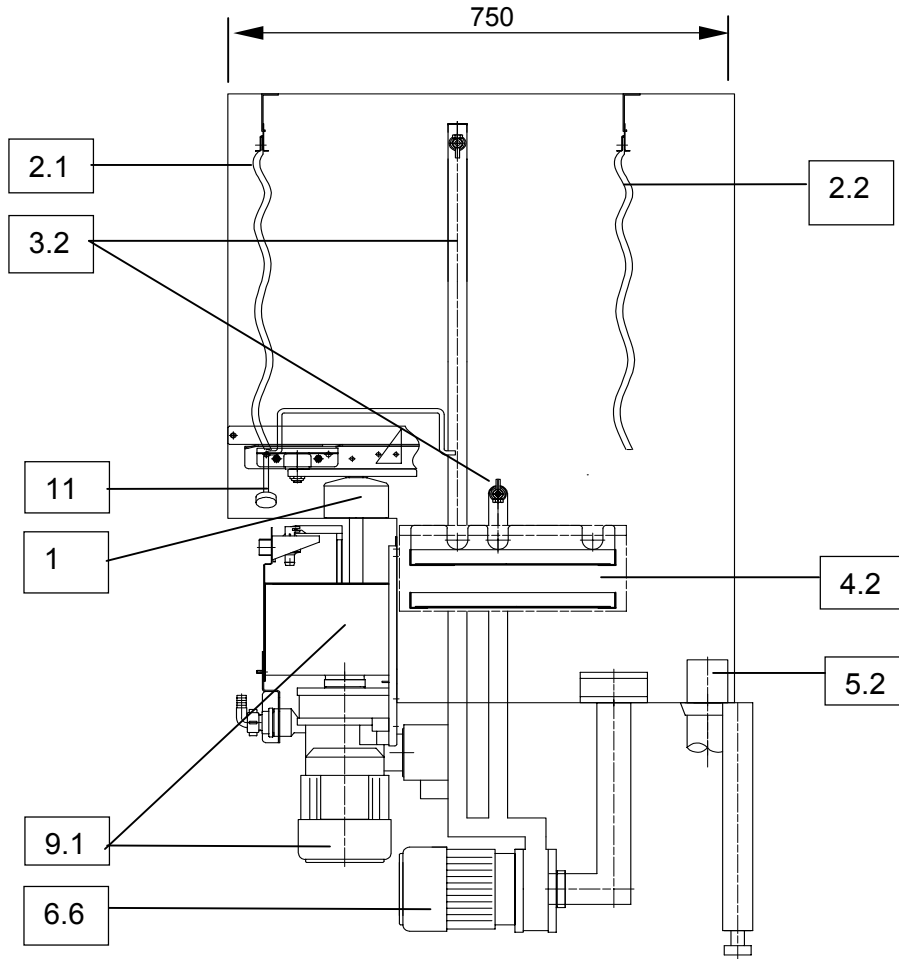

POS.	BEZEICHNUNG	DESIGNATION	DESIGNATION
2.1	VORHANG 650X480	CURTAIN 650X480	RIDEAU 650X480
2.2	VORHANG 650X400	CURTAIN 650X400	RIDEAU 650X400
3.2	WASCHSYSTEM-V	WASH SYSTEM-V	SYSTEME DE LAVAGE-V
4.2	SIEB	SIEVE	TAMIS
5.2	ABLAUF	DRAIN	VIDANGE
6.6	WASCHPUMPE V750	WASH PUMP V750	POMPE DE LAVAGE V750
9.1	FRISCHWASSERNETZTRENNUNG	FRESH WATER MAINS ISOLATING DEVICE	DISPOSITIF DE ISOLEMENT DU RESEAU DE EAU
11	TAKTSCHALTER	INTERVAL SWITCH	INTERRUPTEUR DE SYNCHRONISATION

VA 800 (VORABRÄUMUNG 800MM)



VA 800 (PRE-WASH ZONE 800MM)

VA 800 (ZONE DE PRELAVAGE 800MM)

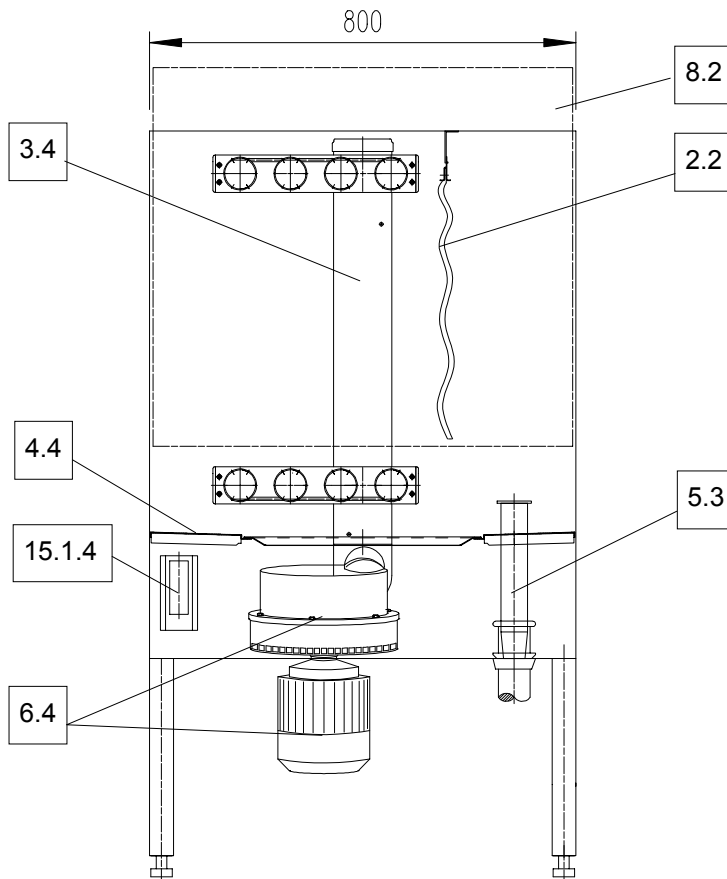

POS.	BEZEICHNUNG	DESIGNATION	DESIGNATION
2.2	VORHANG 650X400	CURTAIN 650X400	RIDEAU 650X400
3.4	WASCHSYSTEM VA/HWZ	WASH SYSTEM VA/HWZ	SYSTEME DE LAVAGE VA/HWZ
4.4	SIEB	SIEVE	TAMIS
5.3	ABLAUF	DRAIN	VIDANGE
6.4	WASCHPUMPE 1,7KW	WASH PUMP 1,7KW	POMPE DE LAVAGE 1,7KW
8.2	TÜR 800	DOOR 800	PORTE 800
15.1.4	SCHWIMMERSCHALTER	FLOATING SWITCH	FLOTTEUR POUR NIVEAU DE BAC

VA 1200 (VORABRÄUMUNG 1200MM)



VA 1200 (PRE-WASH ZONE 1200MM)

VA 1200 (ZONE DE PRELAVAGE 1200MM)

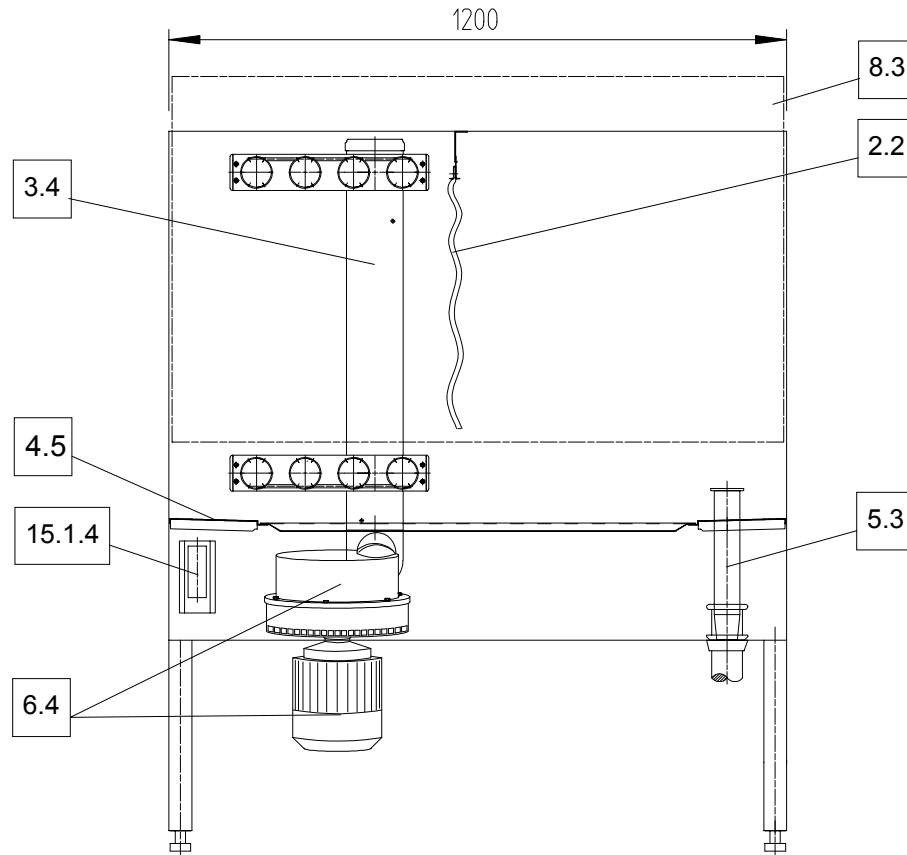

POS.	BEZEICHNUNG	DESIGNATION	DESIGNATION
2.2	VORHANG 650X400	CURTAIN 650X400	RIDEAU 650X400
3.4	WASCHSYSTEM VA/HWZ	WASH SYSTEM VA/HWZ	SYSTEME DE LAVAGE VA/HWZ
4.5	SIEB	SIEVE	TAMIS
5.3	ABLAUF	DRAIN	VIDANGE
6.4	WASCHPUMPE 1,7KW	WASH PUMP 1,7KW	POMPE DE LAVAGE 1,7KW
8.3	TÜR 1200	DOOR 1200	PORTE 1200
15.1.4	SCHWIMMERSCHALTER	FLOATING SWITCH	FLOTTEUR POUR NIVEAU DE BAC

HWZ I 800 (HAUPTWASCHZONE I 800MM)



HWZ I 800 (WASH ZONE I 800MM)

HWZ I 800 (ZONE DE LAVAGE I 800MM)

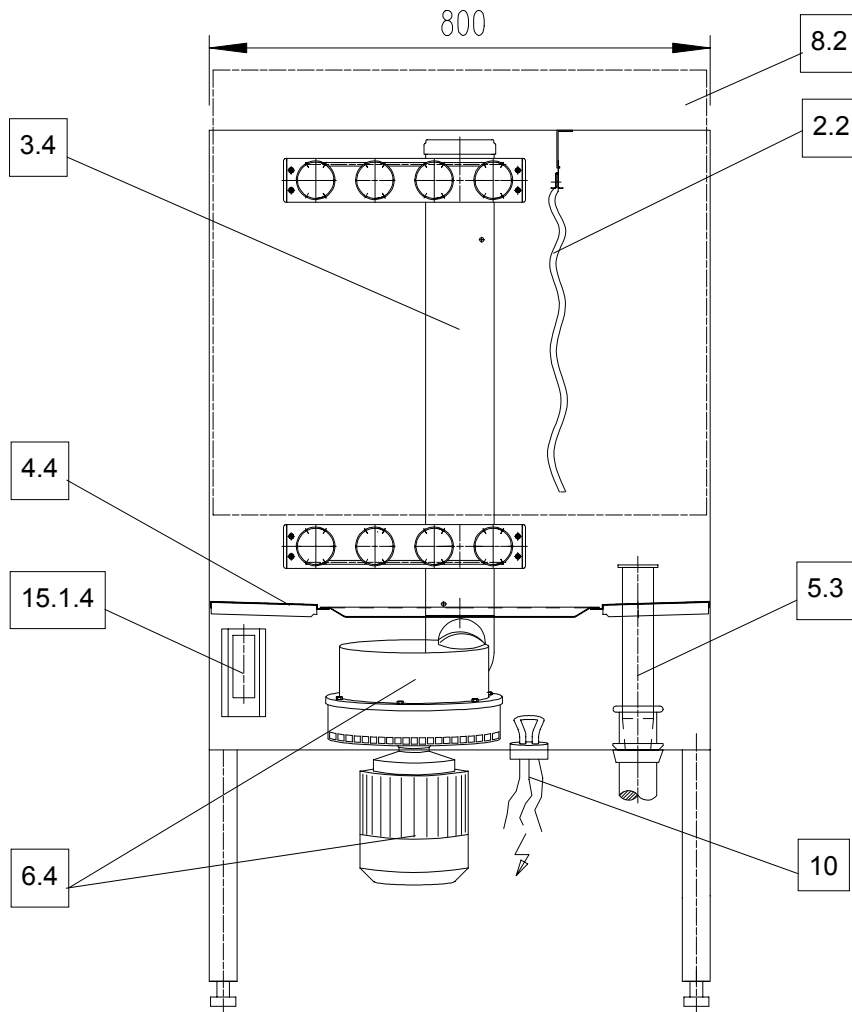

POS.	BEZEICHNUNG	DESIGNATION	DESIGNATION
2.2	VORHANG 650X400	CURTAIN 650X400	RIDEAU 650X400
3.4	WASCHSYSTEM VA/HWZ	WASH SYSTEM VA/HWZ	SYSTEME DE LAVAGE VA/HWZ
4.4	SIEB	SIEVE	TAMIS
5.3	ABLAUF	DRAIN	VIDANGE
6.4	WASCHPUMPE 1,7KW	WASH PUMP 1,7KW	POMPE DE LAVAGE 1,7KW
8.2	TÜR 800	DOOR 800	PORTE 800
10	HEIZUNG	HEATING ELEMENT	RESISTANCE
15.1.4	SCHWIMMERSCHALTER	FLOATING SWITCH	FLOTTEUR POUR NIVEAU DE BAC

HWZ II 800 (HAUPTWASCHZONE II 800MM)

HWZ II 800 (WASH ZONE II 800MM)

HWZ II 800 (ZONE DE LAVAGE II 800MM)

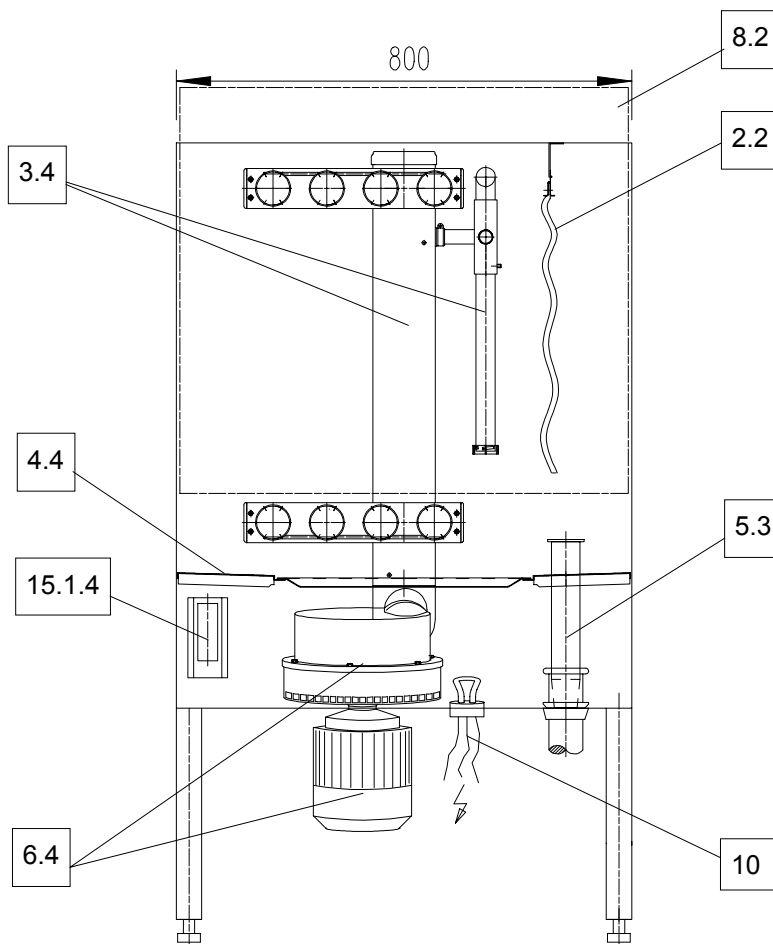

POS.	BEZEICHNUNG	DESIGNATION	DESIGNATION
2.2	VORHANG 650X400	CURTAIN 650X400	RIDEAU 650X400
3.4	WASCHSYSTEM VA/HWZ	WASH SYSTEM VA/HWZ	SYSTEME DE LAVAGE VA/HWZ
4.4	SIEB	SIEVE	TAMIS
5.3	ABLAUF	DRAIN	VIDANGE
6.4	WASCHPUMPE 1,7KW	WASH PUMP 1,7KW	POMPE DE LAVAGE 1,7KW
8.2	TÜR 800	DOOR 800	PORTE 800
10	HEIZUNG	HEATING ELEMENT	RESISTANCE
15.1.4	SCHWIMMERSCHALTER	FLOATING SWITCH	FLOTTEUR POUR NIVEAU DE BAC

HWZ II-P 1200 (HAUPTWASCHZONE II MIT PUMPENKLARSPÜLUNG 1200MM)



HWZ II-P 1200 (WASH ZONE II WITH PUMP RINSE 1200MM)

HWZ II-P 1200 (ZONE DE LAVAGE II AVEC RINCAGE A POMPE 1200MM)

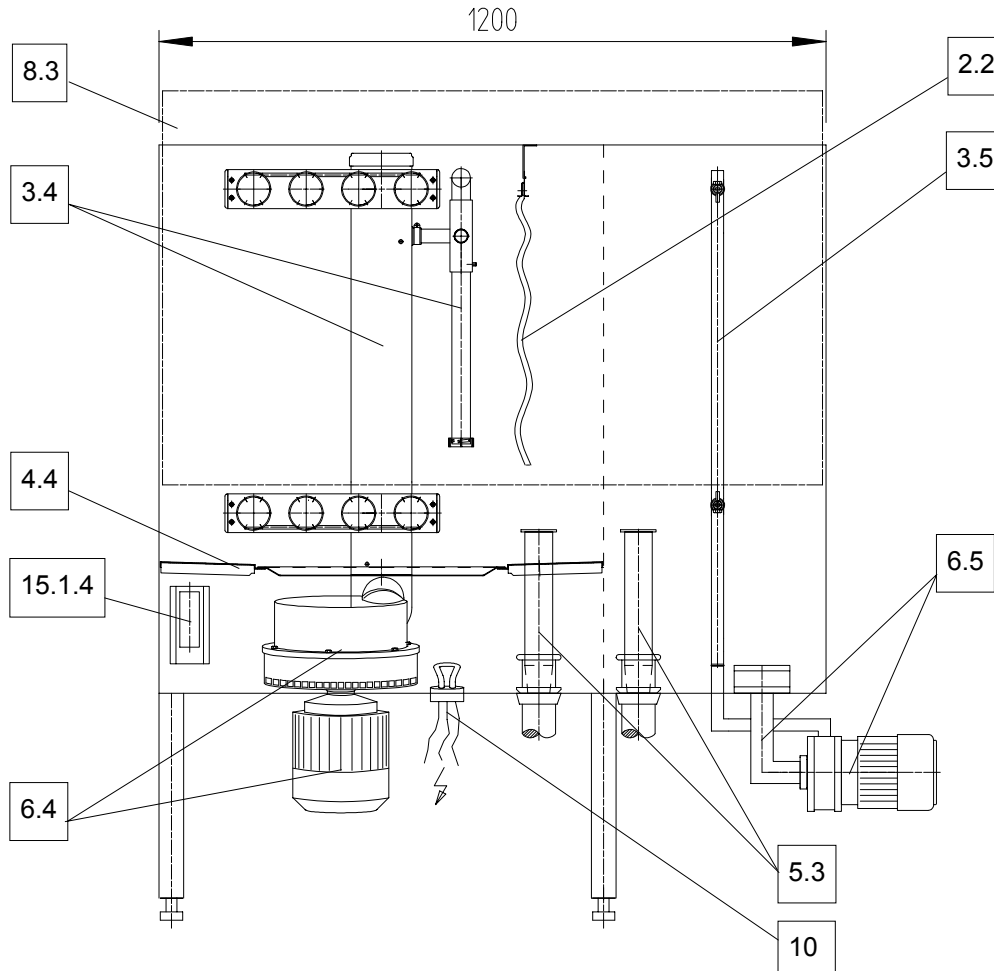

POS.	BEZEICHNUNG	DESIGNATION	DESIGNATION
------	-------------	-------------	-------------

2.2	VORHANG 650X400	CURTAIN 650X400	RIDEAU 650X400
3.4	WASCHSYSTEM VA/HWZ	WASH SYSTEM VA/HWZ	SYSTEME DE LAVAGE VA/HWZ
3.5	PUMPENKLARSPÜLUNG	PUMP FINAL RINSE	RINCAGE FINAL A POMPE
4.4	SIEB	SIEVE	TAMIS
5.3	ABLAUF	DRAIN	VIDANGE
6.4	WASCHPUMPE 1,7KW	WASH PUMP 1,7KW	POMPE DE LAVAGE 1,7KW
6.5	WASCHPUMPE	WASH PUMP	POMPE DE LAVAGE
8.3	TÜR 1200	DOOR 1200	PORTE 1200
10	HEIZUNG	HEATING ELEMENT	RESISTANCE
15.1.4	SCHWIMMERSCHALTER	FLOATING SWITCH	FLOTTEUR POUR NIVEAU DE BAC

F 500 (FRISCHWASSERKLARSPÜLZONE 500MM)

F 500 (FRESH WATER FINAL RINSE ZONE 500MM)

F 500 (ZONE DE RINCAGE FINAL 500MM)

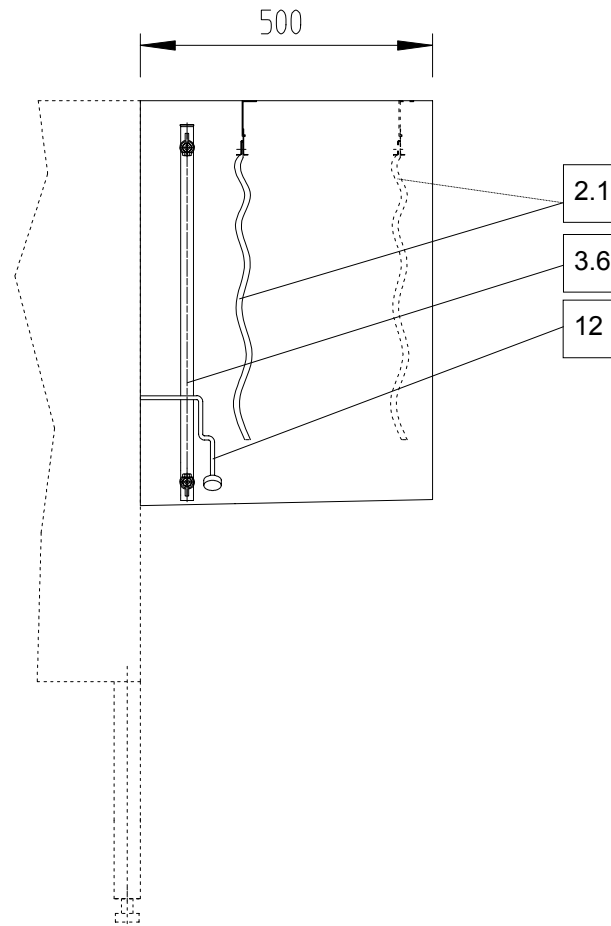

POS.	BEZEICHNUNG	DESIGNATION	DESIGNATION
2.1	VORHANG 650X480	CURTAIN 650X480	RIDEAU 650X480
3.6	FRISCHWASSERKLARSPÜLUNG	FRESH WATER FINAL RINSE	RINCAGE FINAL A L'EAU CLAIRE
12	FRISCHWASSERSPARSCHALTER	FRESH WATER SAVING DEVICE	INT. ECONOMISEUR EAU DE RINCAGE

F + DEMI 500 (FRISCHWASSERKLARSPÜLZONE MIT DEMIKLARSPÜLUNG 500MM)



F + DEMI 500 (FRESH WATER FINAL RINSE ZONE WITH DEMI. RINSING 500MM)

F + DEMI 500 (ZONE DE RINCAGE FINAL AVEC RINCAGE EAU DEMI 500MM)

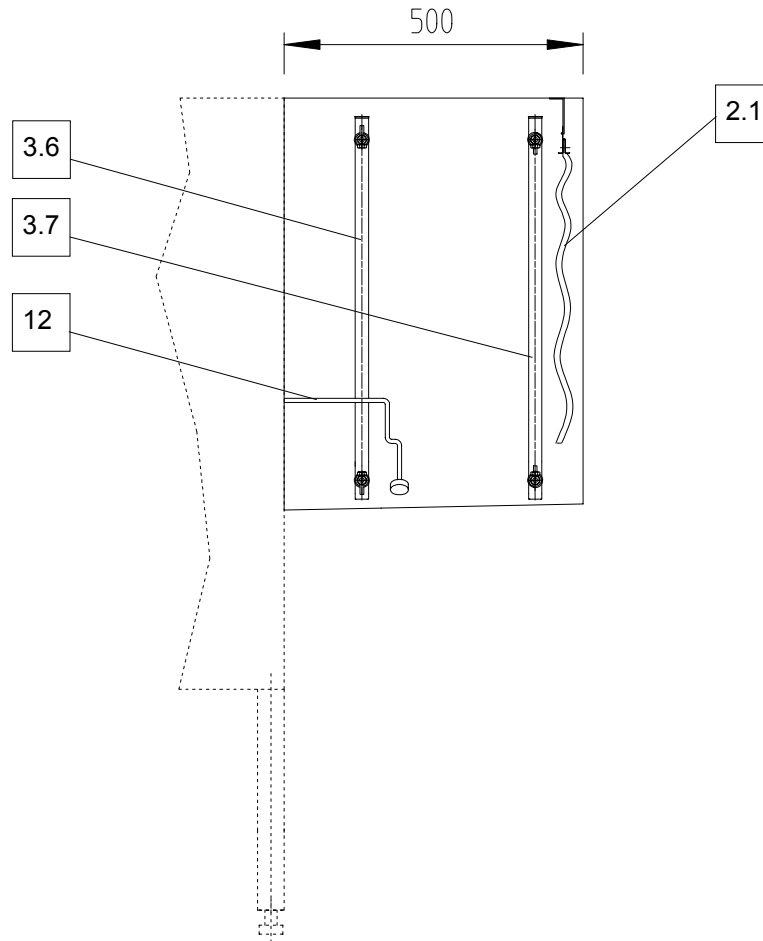

POS.	BEZEICHNUNG	DESIGNATION	DESIGNATION
2.1	VORHANG 650X480	CURTAIN 650X480	RIDEAU 650X480
3.6	FRISCHWASSERKLARSPÜLUNG	FRESH WATER FINAL RINSE	RINCAGE FINAL A L'EAU CLAIRE
3.7	KLARSPÜLUNG-DEMI	FINAL RINSE-DEMI	RINCAGE FINAL-DEMI
12	FRISCHWASSERSPARSCHALTER	FRESH WATER SAVING DEVICE	INT. ECONOMISEUR EAU DE RINCAGE

F + PI 500 (FRISCHWASSERKLARSPÜLZONE MIT INTEGRIERTER PUMPENKLARSPÜLUNG 500MM)



F + PI 500 (FRESH WATER FINAL RINSE ZONE WITH INTEGRATED PUMP RINSE 500MM)

F + PI 500 (ZONE DE RINCAGE FINAL AVEC RINCAGE A POMPE INTEGRE 500MM)

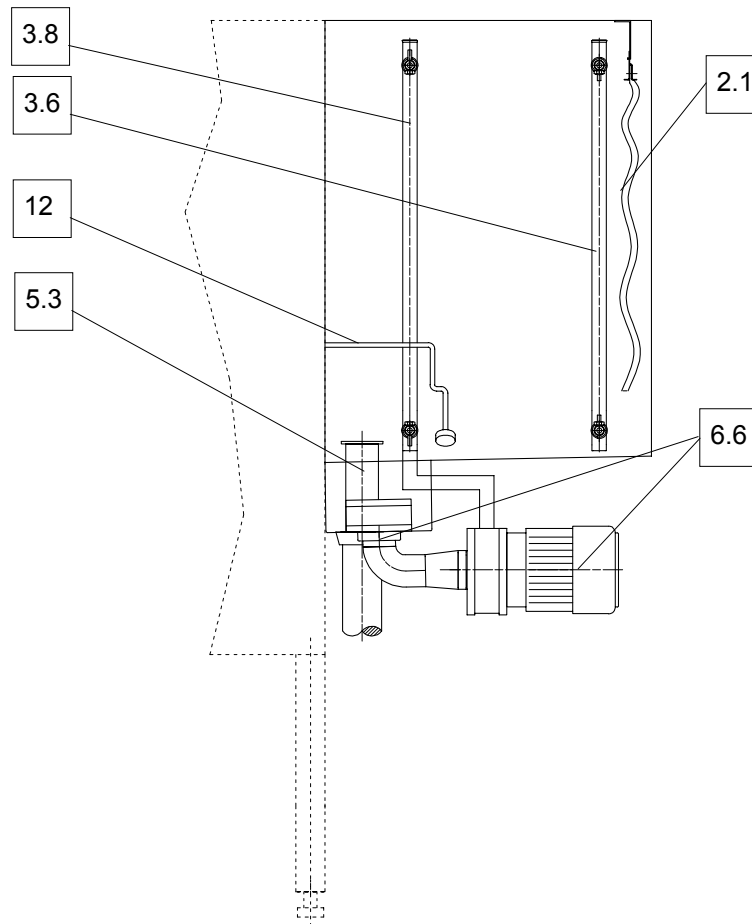

POS.	BEZEICHNUNG	DESIGNATION	DESIGNATION
2.1	VORHANG 650X480	CURTAIN 650X480	RIDEAU 650X480
3.6	FRISCHWASSERKLARSPÜLUNG	FRESH WATER FINAL RINSE	RINCAGE FINAL A L'EAU CLAIRE
3.8	KLARSPÜLUNG-PI	FINAL RINSE-PI	RINCAGE FINAL-PI
5.3	ABLAUF	DRAIN	VIDANGE
6.6	WASCHPUMPE-PI	WASH PUMP-PI	POMPE DE LAVAGE-PI
12	FRISCHWASSERSPARSCHALTER	FRESH WATER SAVING DEVICE	INT. ECONOMISEUR EAU DE RINCAGE

SPRITZSCHUTZTUNNEL



FEEDING TUNNEL

SAS DE ENTREE

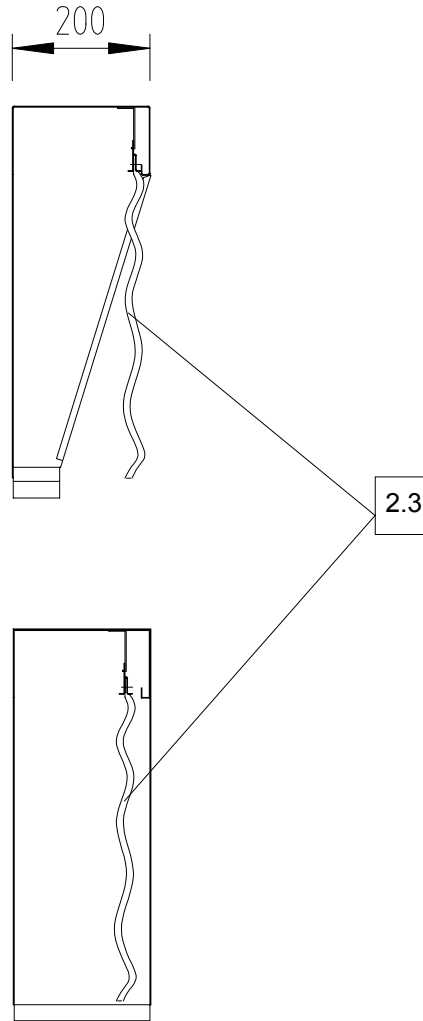

POS.	BEZEICHNUNG	DESIGNATION	DESIGNATION
2.3	VORHANG 610X480	CURTAIN 610X480	RIDEAU 610X480

TROCKNUNG

DRYING

SECHAGE

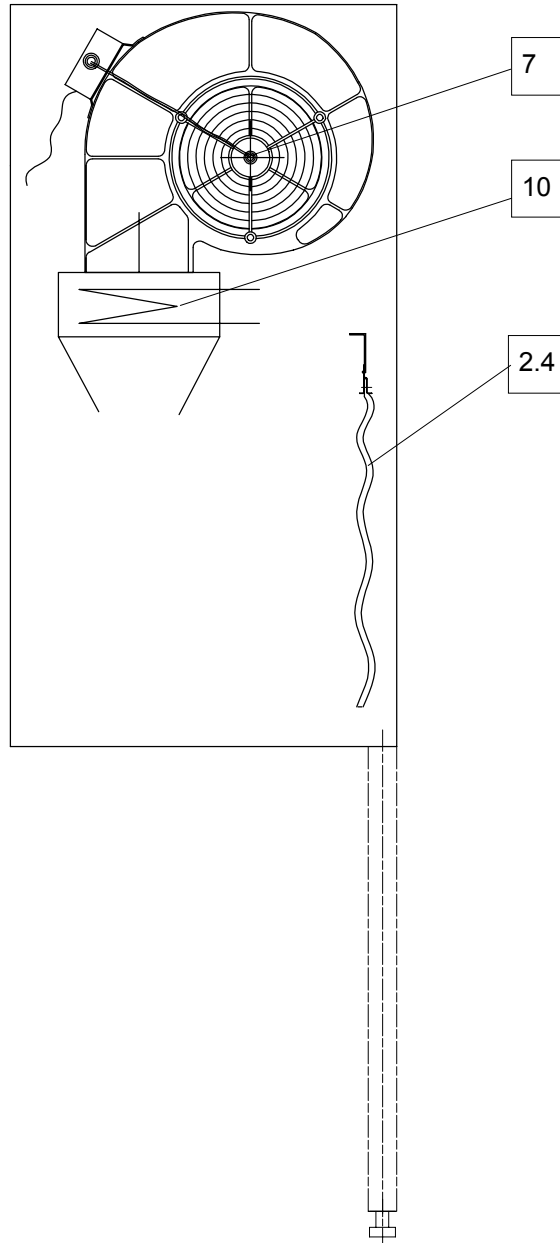

POS.	BEZEICHNUNG	DESIGNATION	DESIGNATION
2.4	VORHANG TROCKNUNG	CURTAIN DRYING	RIDEAU SECHAGE
7	TROCKNUNG	DRYING	SECHAGE
10	HEIZUNG	HEATING ELEMENT	RESISTANCE

1 KORBTRANSPORT



1 BASKET TRANSPORT

1 TRANSPORT DE CASIERS

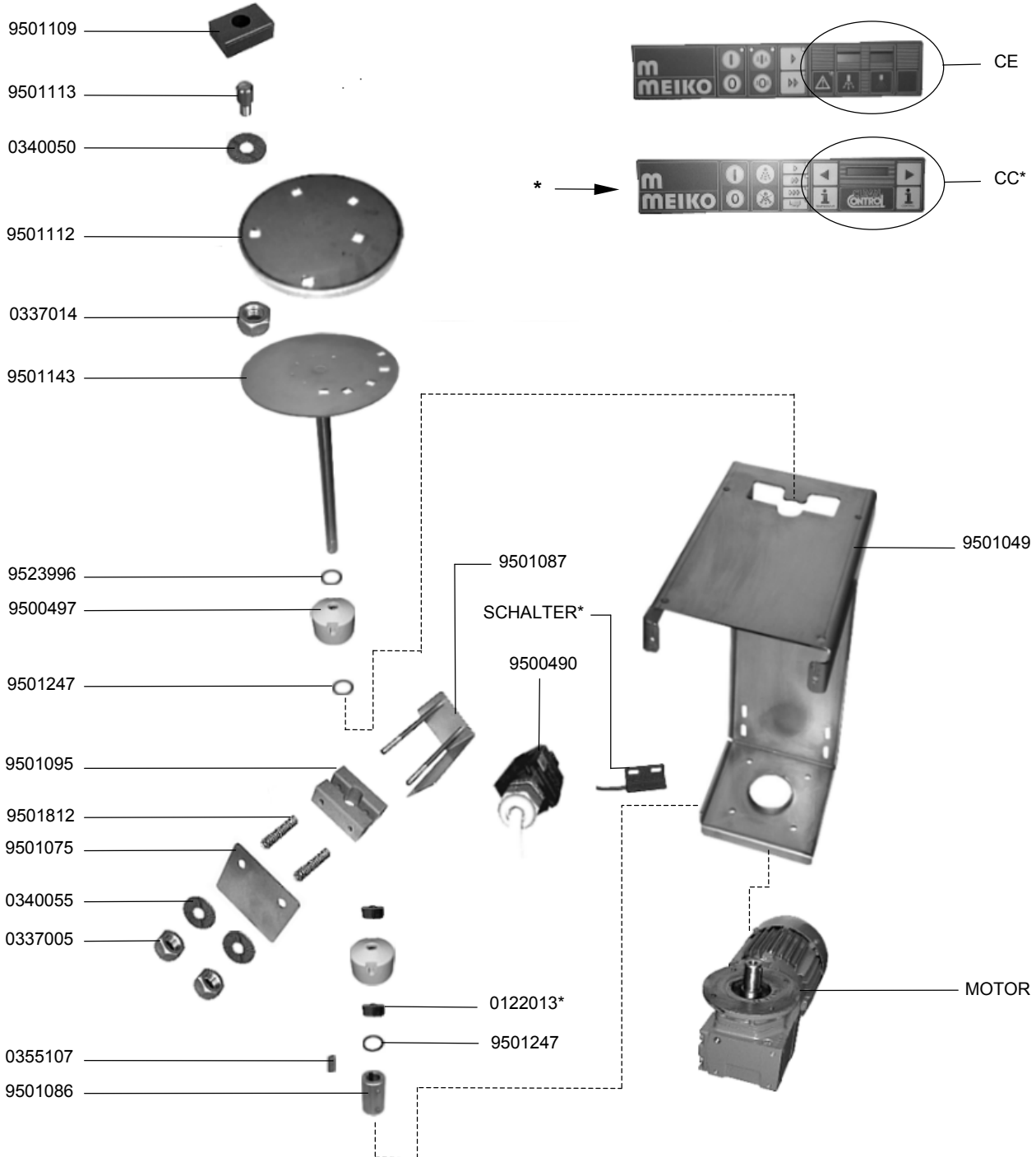

1 KORBTRANSPORT



1 BASKET TRANSPORT

1 TRANSPORT DE CASIERS

IDENT.-NR. IDENT.-NO.	BEZEICHNUNG	DESIGNATION	DESIGNATION	
	MOTOR	SIEHE ELEKTROSCHALTPLAN	SEE ELECTRIC WIRING DIAGRAM	VOIR SCHEMA ELECTRIQUE
	9501049	KONSOLE	CONSOLE	CONSOLE
V	9501109	KULISSENSTEIN	SLIDING BLOCK	COULISSEAU
	9501113	KURBELBOLZEN	CRANK BOLT	BOULON A MANIVELLE
	0340050	SCHEIBE	DISK	DISQUE
	9501112	ABDECKUNG	COVER	CHAPE
	0337014	MUTTER M12	NUT M12	ECROU M12
	9501143	KURBELTRIEB	CRANK GEAR	TRANSMISSION A BIELE
	9523996	DISTANZBUCHSE	SPACER	DOVILLE DE ECARTEMENT
	9500497	ABDECKUNG	COVER	RECOUVREMENT
*	9501247	O-RING	O-RING	BAGUE
	9501095	LAGERSCHALE	BEARING PILLOW	COQUILLE DE SUPPORT
	9501812	DRUCKFEDER	PRESSURE SPRING	RESSORT DE PRESSION
	9501075	SCHALTBLECH	SWITCHING LEVER	LEVIER INTERRUPTEUR
	0340055	SCHEIBE	DISK	DISQUE
	0337005	MUTTER M8	NUT M8	ECROU M8
	0355107	PASSFEDER	FEATHER KEY	RESSORT DE AJUSTAGE
	9501086	STECKKUPPLUNG	SLEEVE COUPLER	DISPOSITIF DE ACCOUPLEMENT
	0122013	MAGNET	MAGNET	AIMANT
	9501087	SPANNPLATTE	TIGHTENING PLATE	TAQUE DE SERRAGE
	9500490	STÖSSEL	TAPPET	POUSSOIR
	SCHALTER	SIEHE ELEKTROSCHALTPLAN	SEE ELECTRIC WIRING DIAGRAM	VOIR SCHEMA ELECTRIQUE

2.1 VORHANG



2.1 CURTAIN

2.1 RIDEAU

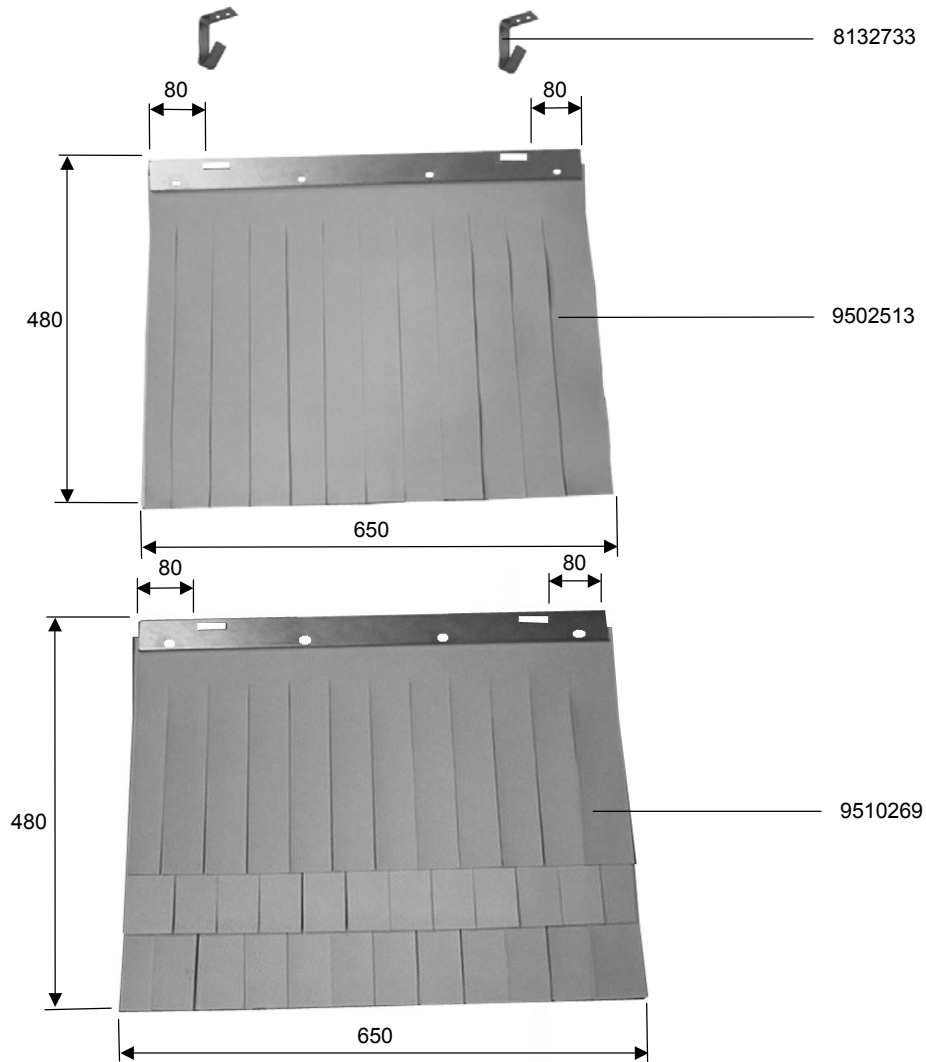

IDENT.-NR. IDENT.-NO.	BEZEICHNUNG	DESIGNATION	DESIGNATION
--------------------------	-------------	-------------	-------------

V 9510269	VORHANG 650X480	CURTAIN 650X480	RIDEAU 650X480
V 9502513	VORHANG 650X480	CURTAIN 650X480	RIDEAU 650X480
8132733	VORHANGBEFESTIGUNG	CURTAIN FIXATION	FIXATION POUR RIDEAU

2.2 VORHANG

2.2 CURTAIN

2.2 RIDEAU

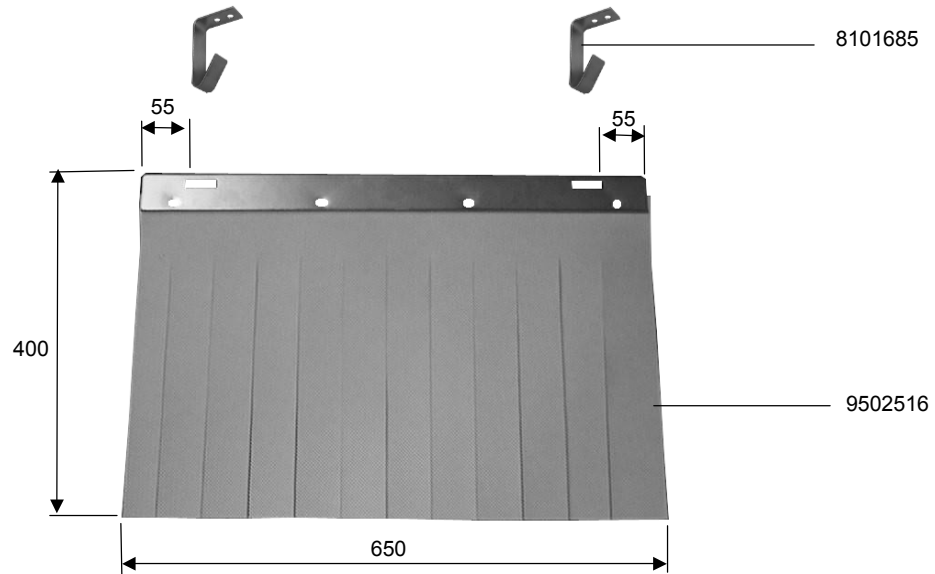

IDENT.-NR. IDENT.-NO.	BEZEICHNUNG	DESIGNATION	DESIGNATION
--------------------------	-------------	-------------	-------------

V 9502516	VORHANG 650X400	CURTAIN 650X400	RIDEAU 650X400
8101685	VORHANGAUFHÄNGEWINKEL	CURTAIN SUSPENSION ANGLE	ANGLE DE ACCROCHAGE DE RIDEAU

2.3 VORHANG



2.3 CURTAIN

2.3 RIDEAU

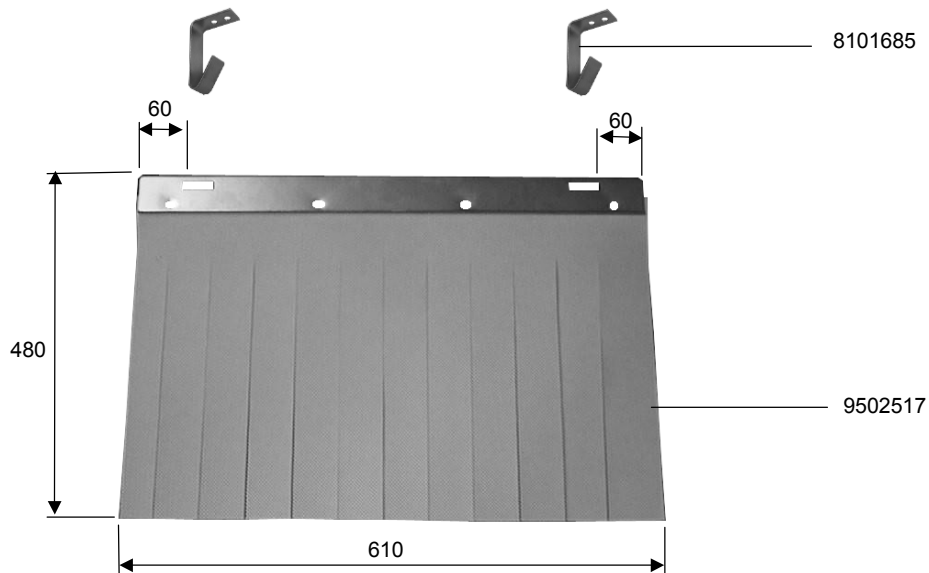

IDENT.-NR. IDENT.-NO.	BEZEICHNUNG	DESIGNATION	DESIGNATION
--------------------------	-------------	-------------	-------------

V 9502517	VORHANG 610X480	CURTAIN 610X480	RIDEAU 610X480
8101685	VORHANGAUFHÄNGEWINKEL	CURTAIN SUSPENSION ANGLE	ANGLE DE ACCROCHAGE DE RIDEAU

2.4 VORHANG

2.4 CURTAIN

2.4 RIDEAU

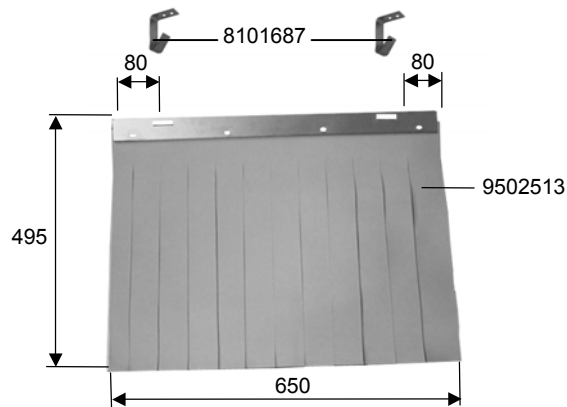
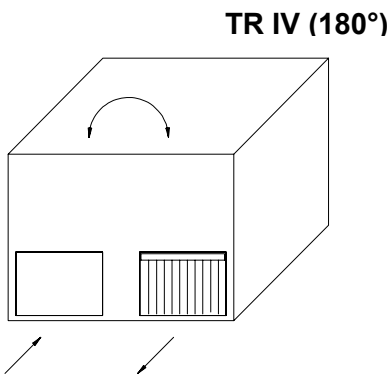
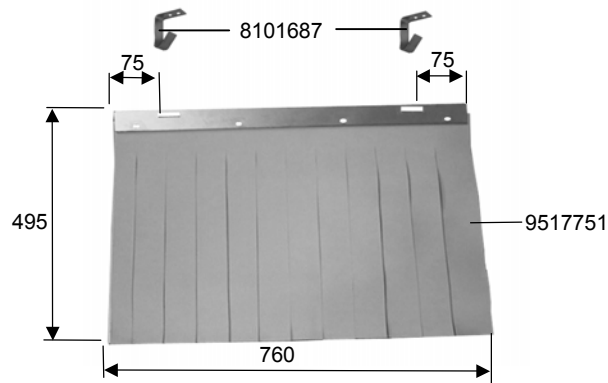
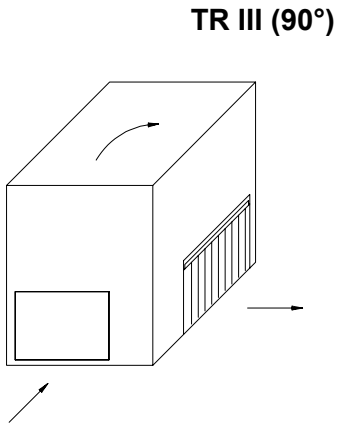
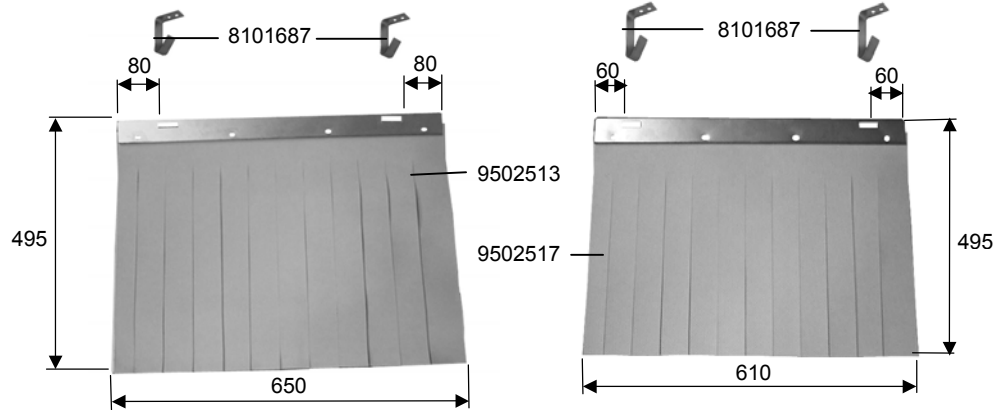
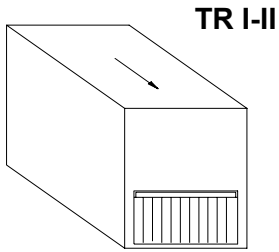

IDENT.-NR. IDENT.-NO.	BEZEICHNUNG	DESIGNATION	DESIGNATION
--------------------------	-------------	-------------	-------------

V 9502513	VORHANG 650X480	CURTAIN B=650X480 A=60	RIDEAU B=650X480 A=60
V 9502517	VORHANG 610X480	CURTAIN B=610X480 A=60	RIDEAU B=610X480 A=60
V 9517751	VORHANG 770X480	CURTAIN B=770X480 A=75	RIDEAU B=770X480 A=75
8101687	VORHANGAUFHÄNGEWINKEL	CURTAIN SUSPENSION ANGLE	ANGLE DE ACCROCHAGE DE RIDEAU

3.1 KV-WASCHSYSTEM



3.1 KV-WASH SYSTEM

3.1 KV-SYSTEME DE LAVAGE

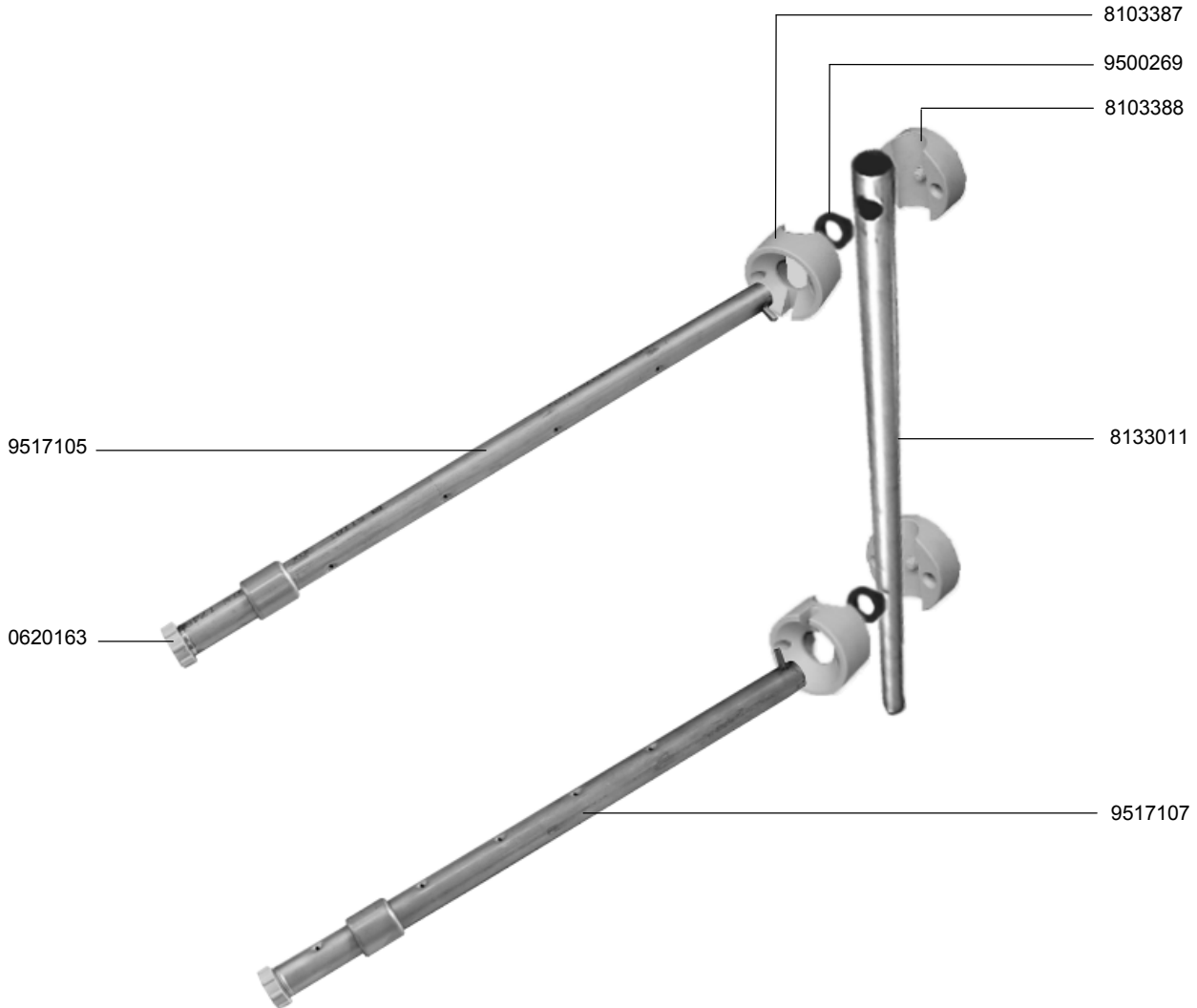

IDENT.-NR. IDENT.-NO.	BEZEICHNUNG	DESIGNATION	DESIGNATION
9517107	WASCHARM UNTEN KPL.	LOWER WASH ARM CPL.	BRAS DE LAVAGE INF. CPL.
8133011	STEIGROHR	ASCENDING PIPE	COLONNE DE LEVATION
* 8103388	KUPPLUNG RÜCKTEIL	CLUTCH BACK PART	ACCOUPLLEMENT ARRIERE
* 9500269	DICHTUNG	PACKING	JOINT
* 8103387	KUPPLUNG VORDERTEIL	CLUTCH FRONT PART	ACCOUPLLEMENT FRONTALE
9517105	WASCHARM OBEN KPL.	UPPER WASH ARM CPL.	BRAS DE LAVAGE SUP. CPL.
* 0620163	VERSCHLUSSKAPPE K163	CLOSING CAP K163	CAPUCHON K163

3.2 CSS 750 / V 750 WASCHSYSTEM



3.2 CSS 750 / V 750 WASH SYSTEM

3.2 CSS 750 / V 750 SYSTEM DE LAVAGE

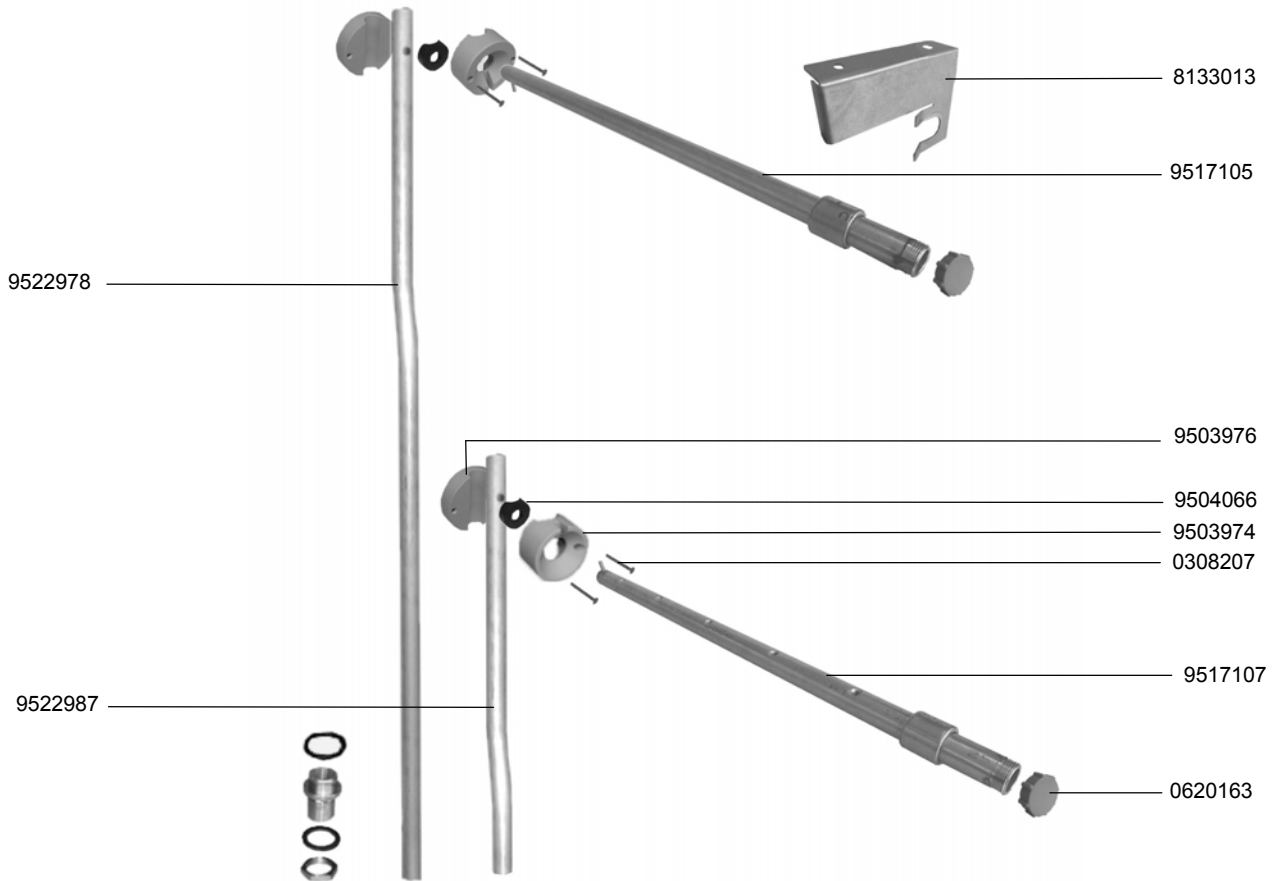

IDENT.-NR. IDENT.-NO.	BEZEICHNUNG	DESIGNATION	DESIGNATION
* 0620163	KAPPE	CAP	CAPOUCHON
9517107	WASCHARM UNTEN KPL.	LOWER WASH ARM CPL.	BRAS DE LAVAGE INF. CPL.
0308207	SCHRAUBE M4X10	SCREW M4X10	VIS M4X10
* 9503974	KUPPLUNG VORDERTEIL	CLUTCH FRONT PART	ACCOUPLLEMENT FRONTALE
* 9504066	DICHTUNG	PACKING	JOINT
* 9503976	KUPPLUNG RÜCKTEIL	CLUTCH BACK PART.	ACCOUPLLEMENT ARRIERE
9517105	WASCHARM OBEN KPL.	UPPER WASH ARM CPL.	BRAS DE LAVAGE SUP. CPL.
8133013	HALTERUNG	SUPPORT	SUPPORT
9522978	STEIGROHR	ASCENDING PIPE	COLONNE DE LEVATION
9522987	STEIGROHR	ASCENDING PIPE	COLONNE DE LEVATION

3.2.1 CSS TOP-SPÜLARM



3.2.1 CSS TOP-RINSE ARM

3.2.1 CSS TOP-BRAS DE LAVAGE

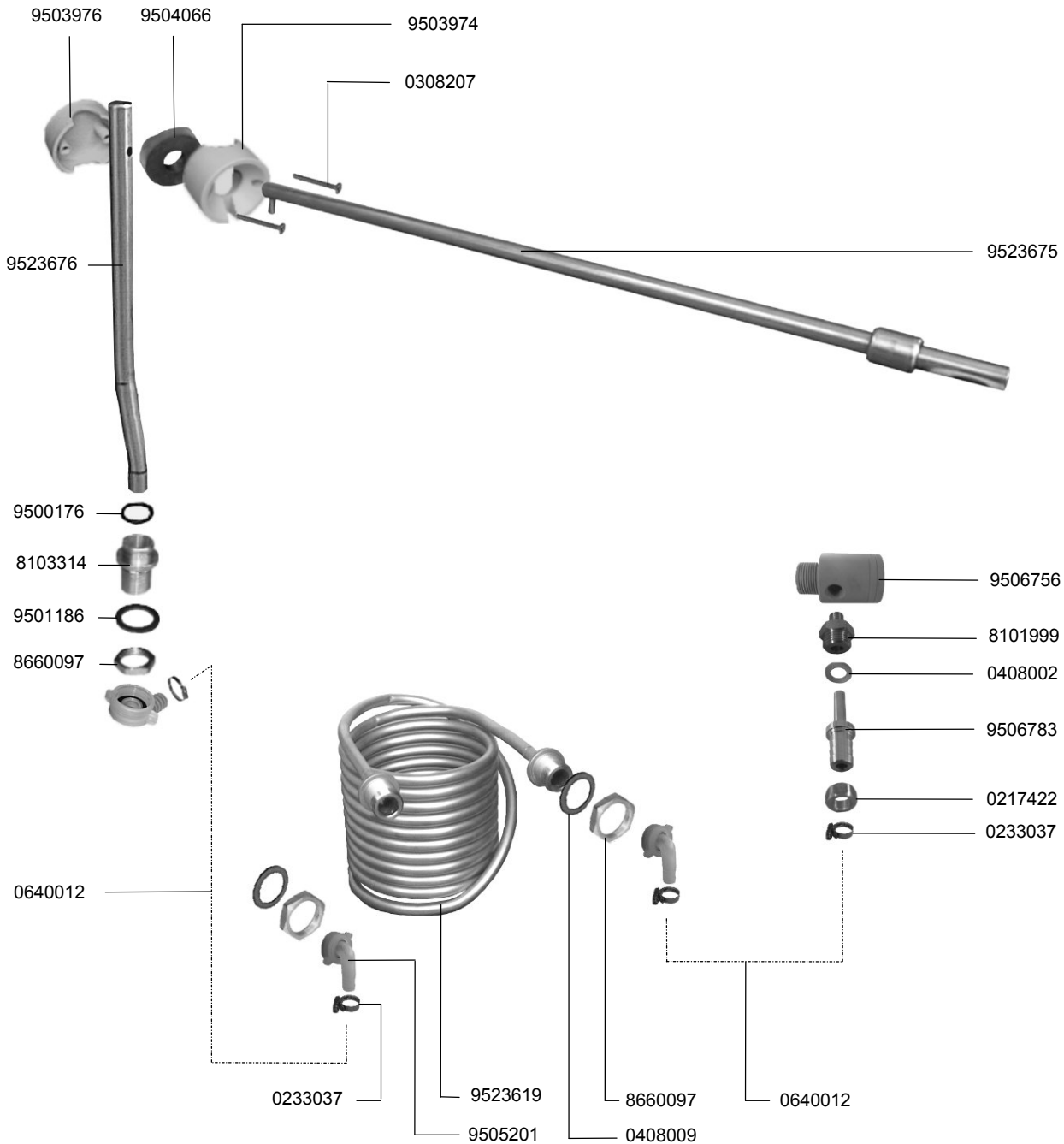

3.2.1 CSS TOP-SPÜLARM



3.2.1 CSS TOP-RINSE ARM

3.2.1 CSS TOP-BRAS DE LAVAGE

IDENT.-NR. IDENT.-NO.	BEZEICHNUNG	DESIGNATION	DESIGNATION
0233037	SCHLAUCHKLEMME	HOSE WIRE CLAMP	COLLIER DE SERRAGE
0217422	ÜBERWURFMUTTER	SLEEVE NUT	ECROU RACCORD
9506783	BLLENDE	STOP	OBTURATEUR
0408002	DICHTUNG	PACKING	JOINT
8101999	ADAPTER	ADAPTER	ADAPTEUR
9506756	VERBINDUNGSTEIL	CONNECTION PART	PIECE DE CONNEXION
9523675	SPÜLARM CSS BYPASS	FINAL RINSE ARM CSS	BRAS DE RINCAGE FINAL CSS
0308207	SCHRAUBE M4X10	SCREW M4X10	VIS M4X10
* 9503974	KUPPLUNG VORDERTEIL	CLUTCH FRONT PART	ACCOUPEMENT FRONTALE
* 9504066	DICHTUNG	PACKING	JOINT
* 9503976	KUPPLUNG RÜCKTEIL	CLUTCH BACK PART	ACCOUPEMENT ARRIERE
9523676	STEIGROHR	ASCENDING PIPE	COLONNE DE LEVATION
* 9500176	O-RING	O-RING	BAGUE
8103314	TANKDURCHFÜHRUNG	TANKTHROUGH-LEAD	TRAVERSEE DU BAC
9501186	DICHTUNG	PACKING	JOINT
8660097	MUTTER	NUT	ECROU
0640012	SCHLAUCH	HOSE	TUYAU
0233037	SCHLAUCHKLEMME	HOSE WIRE CLAMP	COLLIER DE SERRAGE
9505201	ANSCHLUSSWINKEL	CONNECTION ANGLE	ANGLE DE CONNEXION
9523619	WÄRMETAUSCHER	HEAT EXCHANGER	ECHANGEUR DE CHALEUR
0408009	DICHTUNG	PACKING	JOINT

3.4.1 VA/HWZ-WASCHSYSTEM



3.4.1 VA/HWZ -WASH SYSTEM

3.4.1 SYSTEME DE LAVAGE- VA/HWZ

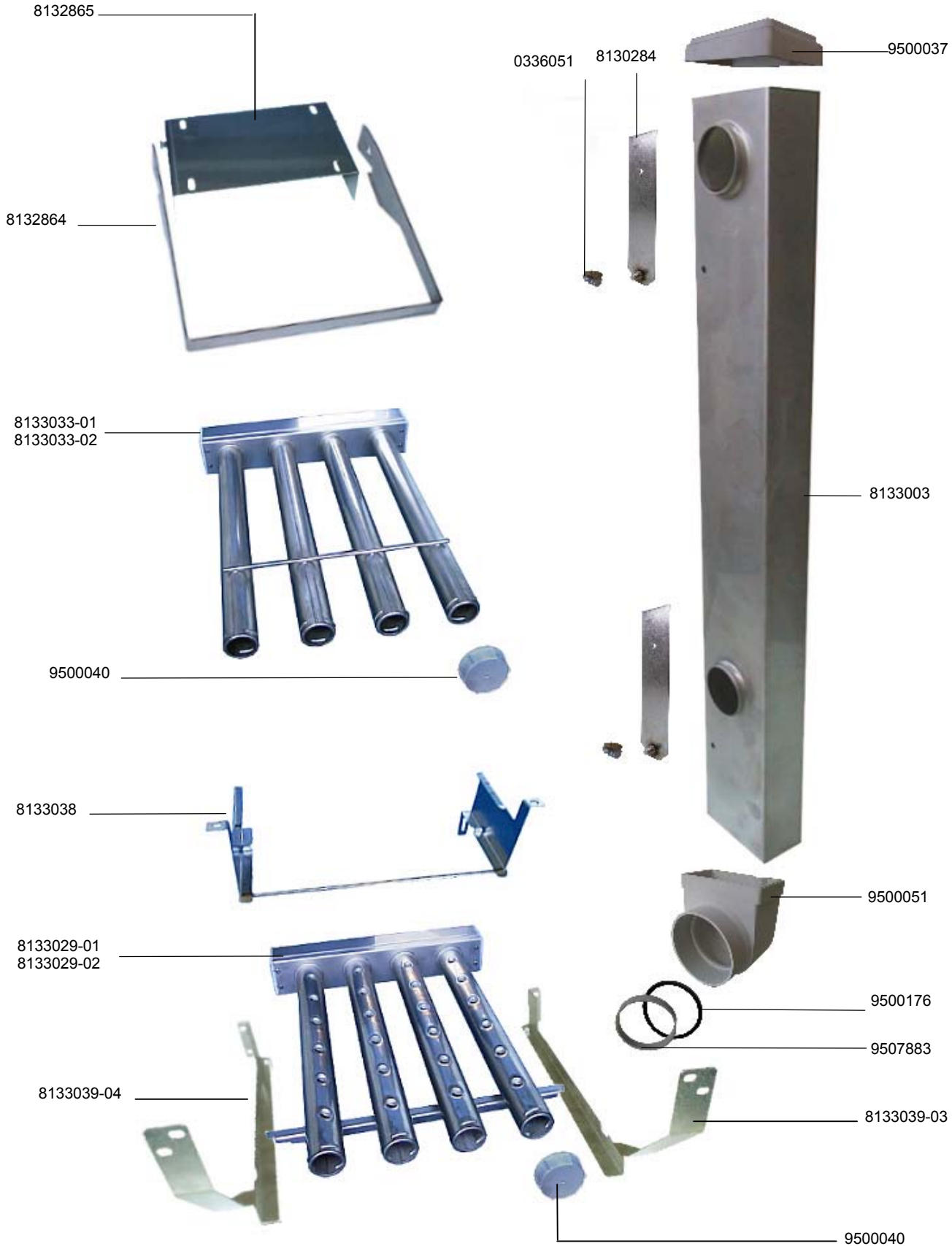

3.4.1 VA/HWZ-WASCHSYSTEM



3.4.1 VA/HWZ -WASH SYSTEM

3.4.1 SYSTEME DE LAVAGE- VA/HWZ

IDENT.-NR. IDENT.-NO.	BEZEICHNUNG	DESIGNATION	DESIGNATION
9507883	STÜTZRING	SUPPORT RING	BAGUE DE SUPPORT
* 9500176	O-RING	O-RING	O-RING
9500051	STEIGROHRANSCHLUSS	ASCENDING PIPE CONNECTION	CONNEXION POUR COLONNE DE LEVATION
8133003	STEIGROHR	ASCENDING PIPE	COLONNE DE LEVATION
9500037	STEIGROHRDECKEL	LID	COUVERCLE
8130284	DROSSELBLECH	THROTTLE PLATE	TOLE DE D'ETRANGLEMENT
0336051	HUTMUTTER M6	CAP NUT M6	ECROU BORGNE M6
8132865	BEFESTIGUNGSPLATTE	FIXATION PLATE	PLAQUE DE FIXATION
8132864	BÜGEL	SUPPORT	SUPPORT
8133033-01	WASCHSYSTEM OBEN KPL. L-R	UPPER WASHSYSTEM CPL. L-R	SYSTEME DE LAVAGE SUP. CPL.G-D
8133033-02	WASCHSYSTEM OBEN KPL. R-L	UPPER WASHSYSTEMCPL. R-L	SYSTEME DE LAVAGE SUP. CPL.D-G
* 9500040	VERSCHLUSSKAPPE	CLOSING CAP	CAPOUCHON
8133038	AUFLAGE	SUPPORT	SUPPORT
8133029-01	WASCHSYSTEM UNTEN KPL. L-R	LOWER WASHSYSTEM CPL. L-R	SYSTEME DE LAVAGE INF. CPL G-D
8133029-02	WASCHSYSTEM UNTEN KPL. R-L	LOWER WASHSYSTEM CPL. R-L	SYSTEME DE LAVAGE INF. CPL D-G
8133039-03	WASCHSYSTEMAUFLAGE RECHTS UNTEN	WASCHSYSTEMAUFLAGE RECHTS UNTEN	SUPPORT OF WASH SYSTEM BOTTOM - RIGHT HAND SIDE
8133039-04	WASCHSYSTEMAUFLAGE LINKS UNTEN	WASCHSYSTEMAUFLAGE LINKS UNTEN	SUPPORT OF WASH SYSTEM BOTTOM - LEFT HAND SIDE

3.4.2 VA/HWZ-WASCHSYSTEM



3.4.2 VA/HWZ -WASH SYSTEM

3.4.2 SYSTEME DE LAVAGE- VA/HWZ

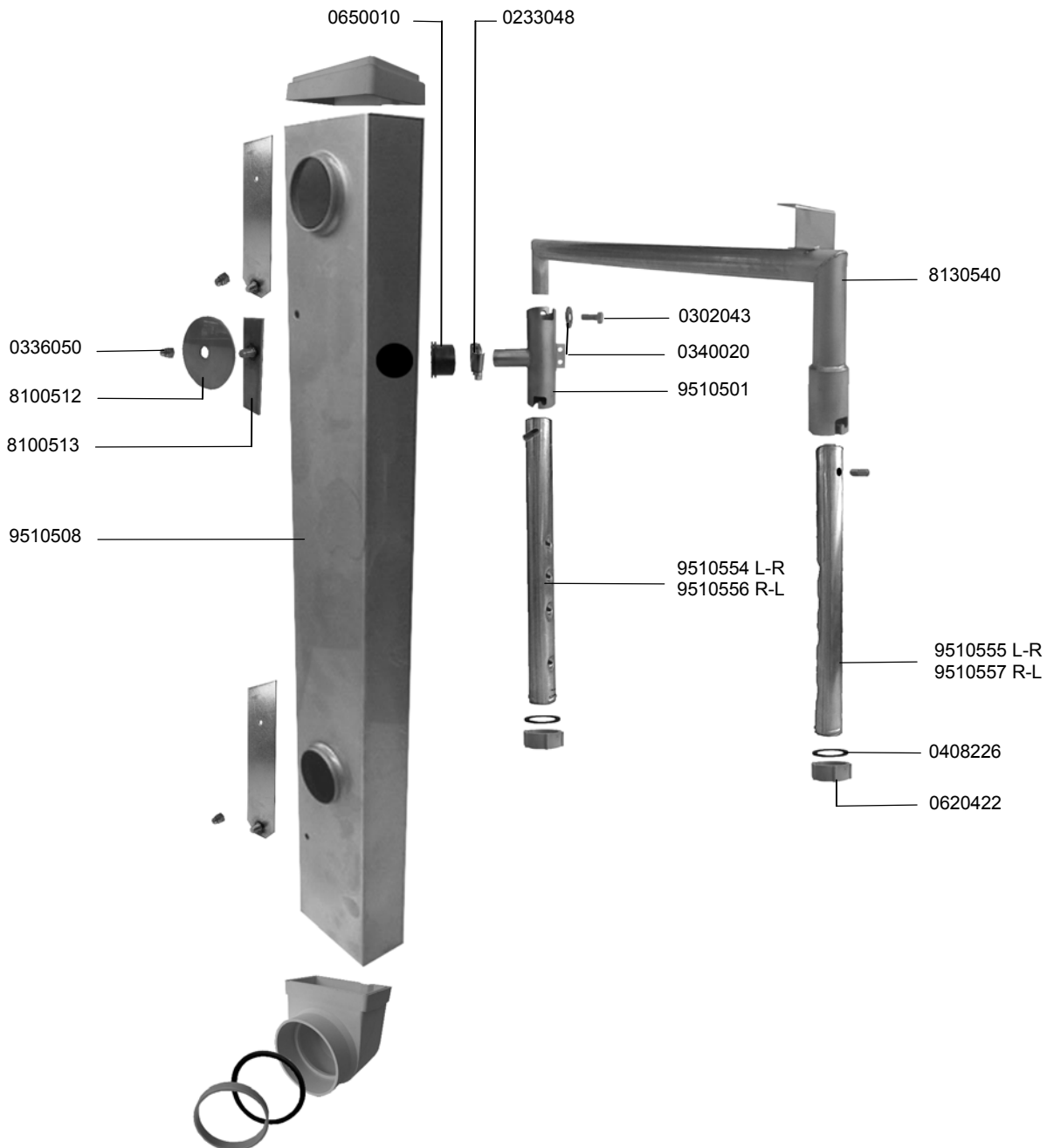

3.4.2 VA/HWZ-WASCHSYSTEM



3.4.2 VA/HWZ -WASH SYSTEM

3.4.2 SYSTEME DE LAVAGE- VA/HWZ

IDENT.-NR. IDENT.-NO.	BEZEICHNUNG	DESIGNATION	DESIGNATION
* 0620422	VERSCHLUSSKAPPE	CLOSING CAP	CAPOUCHON
V 0408226	DICHTUNG	PACKING	JOINT
9510555	WASCHARM KPL. L-R	WASHARM CPL. L-R	BRAS DE LAVAGE CPL.G-D
9510557	WASCHARM KPL. R-L	WASHARM CPL. R-L	BRAS DE LAVAGE CPL.D-G
9510554	WASCHARM KPL. L-R	WASHARM CPL. L-R	BRAS DE LAVAGE CPL.G-D
9510556	WASCHARM KPL. R-L	WASHARM CPL. R-L	BRAS DE LAVAGE CPL.D-G
9510501	BAJONETTROHR	DISTRIBUTING BAYONET	BAIONNETTE DISTRIBUTEUR
0340020	SCHEIBE	DISK	DISQUE
0302043	SKT.SCHRAUBE M5X10	HEXAGONE SCREW M5X10	VIS A 6 PANS M5X10
8130540	VERTEILERROHR	DISTRIBUTING PIPE	TUYAU DISTRIBUTEUR
0233048	SCHLAUCHKLEMME 20-32	HOSE WIRE CLAMP 20-32	COLLIER DE SERRAGE 20-32
0650010	GUMMITÜLLE	RUBBER BUSHING	DOUILLE EN CAOUTCHOUC
0336050	HUTMUTTER M5	CAP NUT M5	ECROU BORGNE M5
8100512	SCHEIBE	DISK	DISQUE
8100513	STEIGROHRVERSCHLUSSBLECH	STOPPER	TOLE DE OBTURATION
9510508	STEIGROHR	ASCENDING PIPE	COLONNE DE LEVATION

3.5 PUMPENKLARSPÜLUNG



3.5 PUMP FINAL RINSE

3.5 RINCAGE FINAL A POMPE

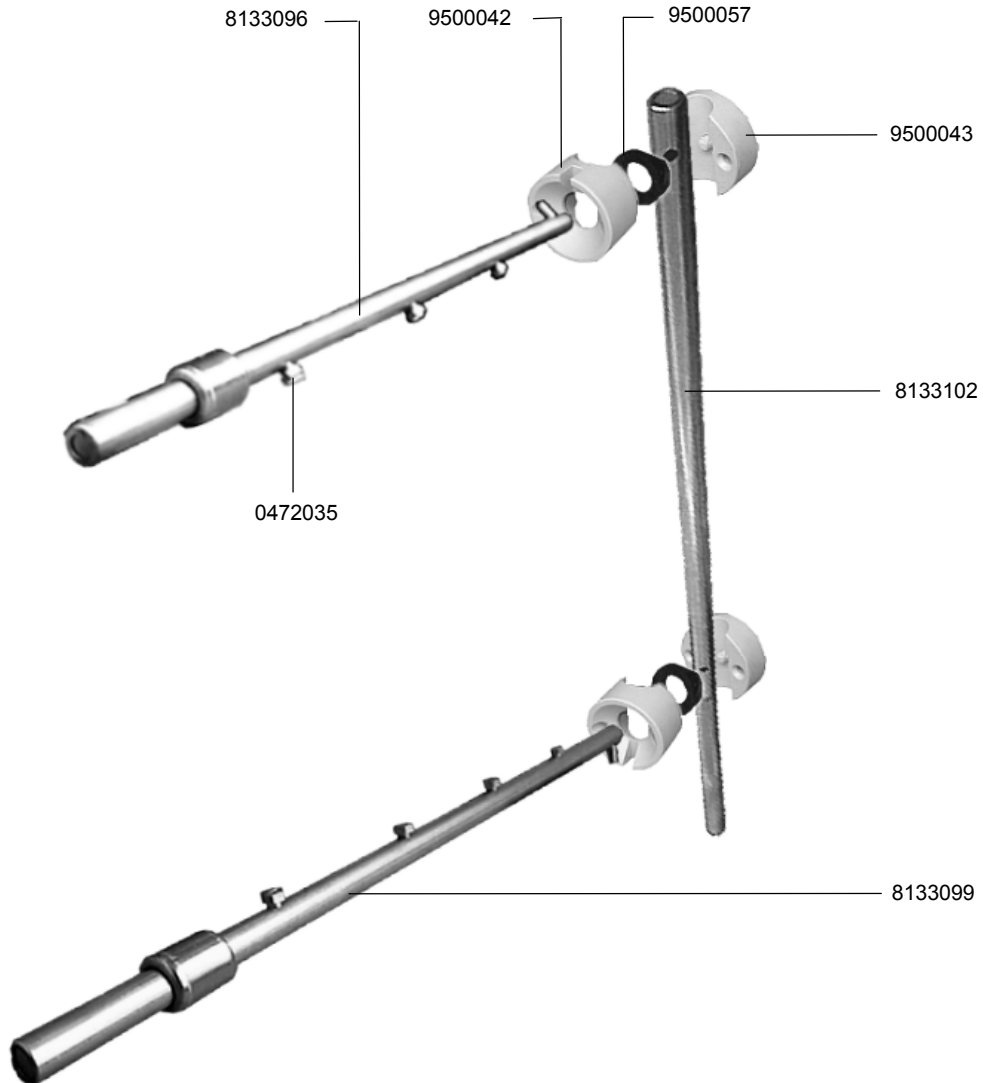

IDENT.-NR. IDENT.-NO.	BEZEICHNUNG	DESIGNATION	DESIGNATION
8133099	WASCHARM UNTEN KPL.	LOWER WASH ARM CPL.	BRAS DE LAVAGE INF. CPL.
8133102	STEIGROHR	ASCENDING PIPE	COLONNE DE LEVATION
* 9500043	KUPPLUNG RÜCKTEIL	CLUTCH BACK PART	ACCOUPEMENT ARRIERE
* 9500057	DICHTUNG	PACKING	JOINT
* 9500042	KUPPLUNG VORDERTEIL	CLUTCH FRONT PART	ACCOUPEMENT FRONTALE
8133096	WASCHARM OBEN KPL.	UPPER WASH ARM CPL.	BRAS DE LAVAGE SUP. CPL.
* 0472035	DÜSE	NOZZLE	GICLEUR

3.6.1 FRISCHWASSERKLARSPÜLUNG



3.6.1 FRESH WATER FINAL RINSE

3.6.1 RINCAGE FINAL A L'EAU CLAIRE

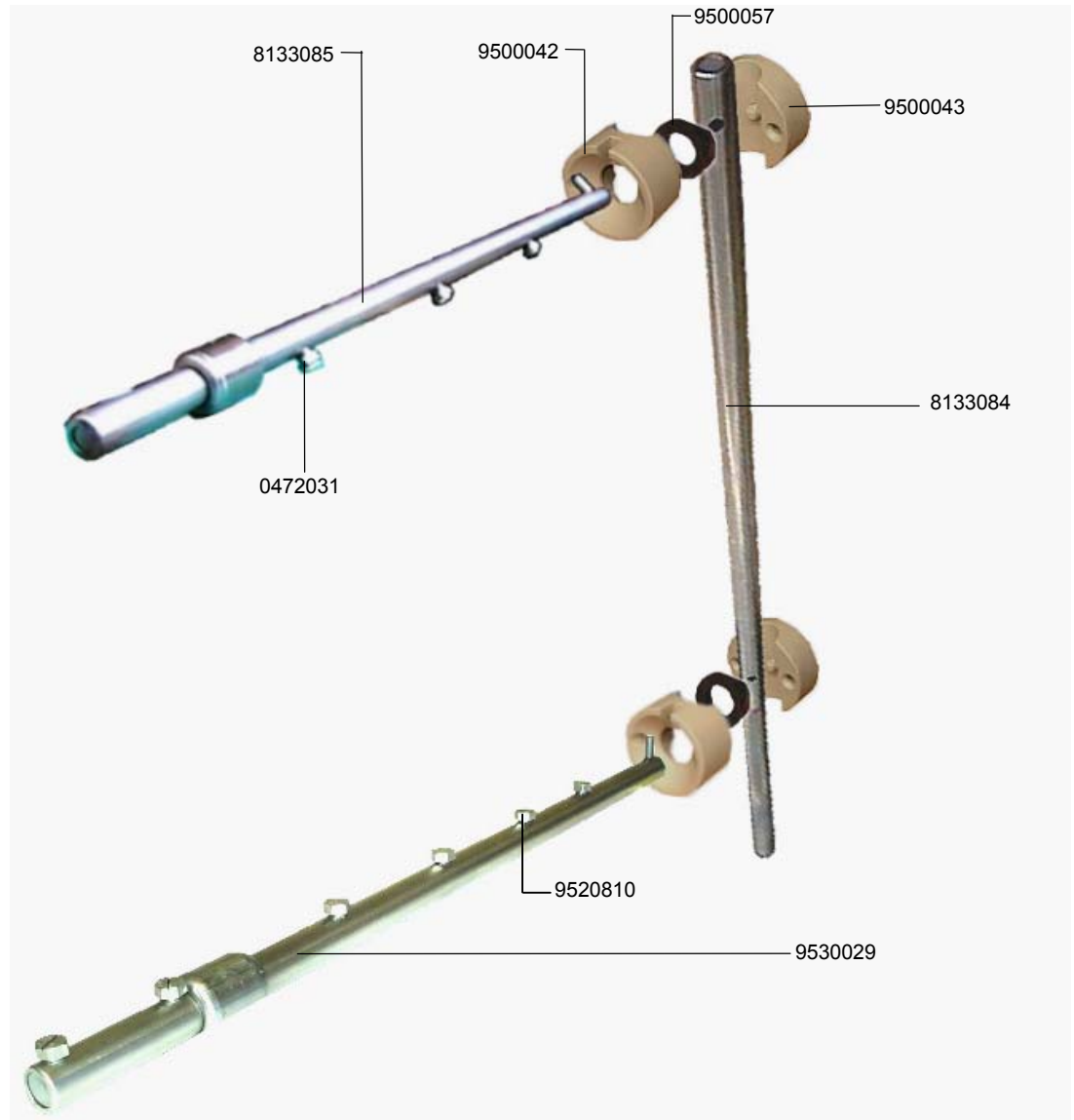

IDENT.-NR. IDENT.-NO.	BEZEICHNUNG	DESIGNATION	DESIGNATION
9530029	WASCHARM UNTEN KPL.	LOWER WASH ARM CPL.	BRAS DE LAVAGE INF. CPL.
* 9520810	DÜSE UNTEN	LOWER NOZZLE	GICLEUR INF.
8133084	STEIGROHR	ASCENDING PIPE	COLONNE DE LEVATION
* 9500043	KUPPLUNG RÜCKTEIL	CLUTCH BACK PART	ACCOUPLLEMENT ARRIERE
* 9500057	DICHTUNG	PACKING	JOINT
* 9500042	KUPPLUNG VORDERTEIL	CLUTCH FRONT PART	ACCOUPLLEMENT FRONTALE
8133085	WASCHARM OBEN KPL	UPPER WASH ARM CPL.	BRAS DE LAVAGE SUP. CPL.
* 0472031	DÜSE OBEN	UPPER NOZZLE	GICLEUR SUP.

3.7 DEMI-KLARSPÜLUNG



3.7 DEMI- FINAL RINSE

3.7 RINCAGE FINAL-DEMI

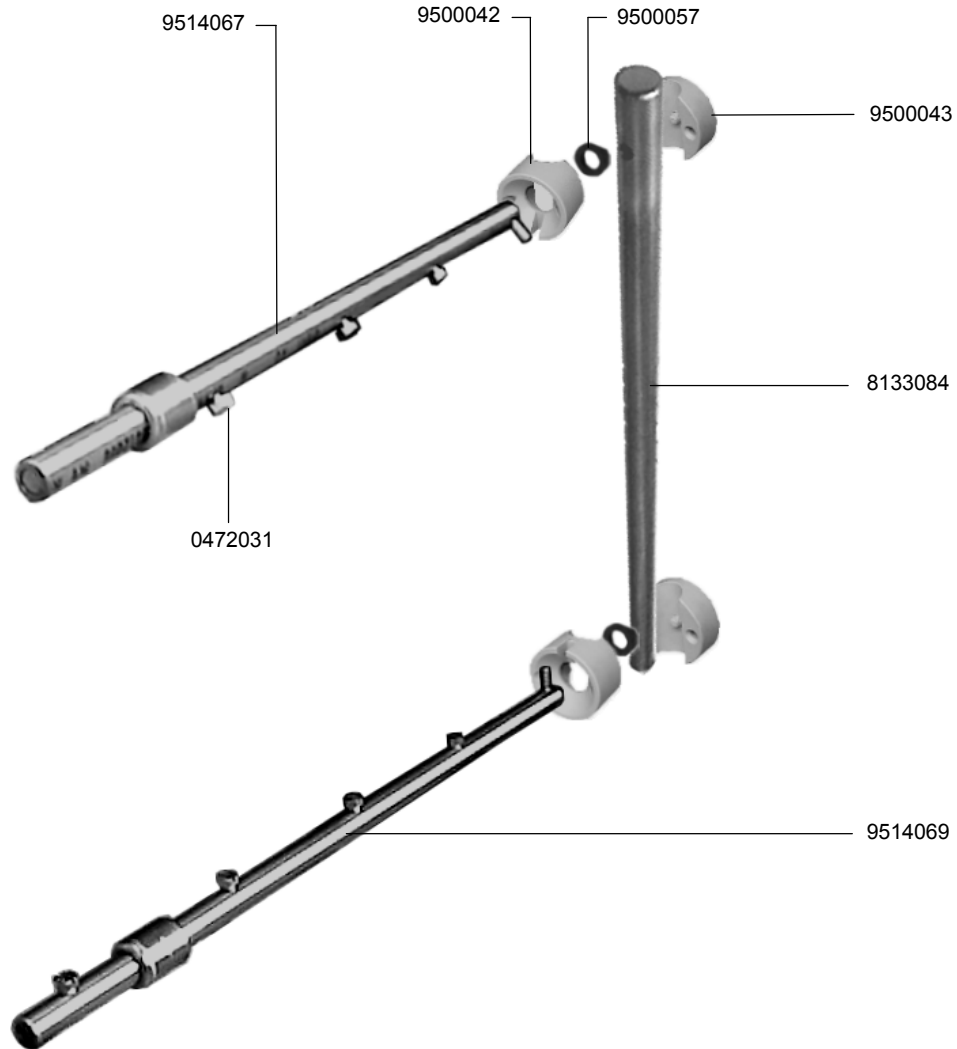

IDENT.-NR. IDENT.-NO.	BEZEICHNUNG	DESIGNATION	DESIGNATION
9514069	WASCHARM UNTEN KPL.	LOWER WASH ARM CPL.	BRAS DE LAVAGE INF. CPL.
8133084	STEIGROHR	ASCENDING PIPE	COLONNE DE LEVATION
* 9500043	KUPPLUNG RÜCKTEIL	CLUTCH BACK PART	ACCOUPEMENT ARRIERE
* 9500057	DICHTUNG	PACKING	JOINT
* 9500042	KUPPLUNG VORDERTEIL	CLUTCH FRONT PART	ACCOUPEMENT FRONTALE
9514067	WASCHARM OBEN KPL.	UPPER WASH ARM CPL.	BRAS DE LAVAGE SUP. CPL.
* 0472031	DÜSE	NOZZLE	GICLEUR

3.8 PI-KLARSPÜLUNG

3.8 PI- FINAL RINSE

3.8 RINCAGE FINAL-PI

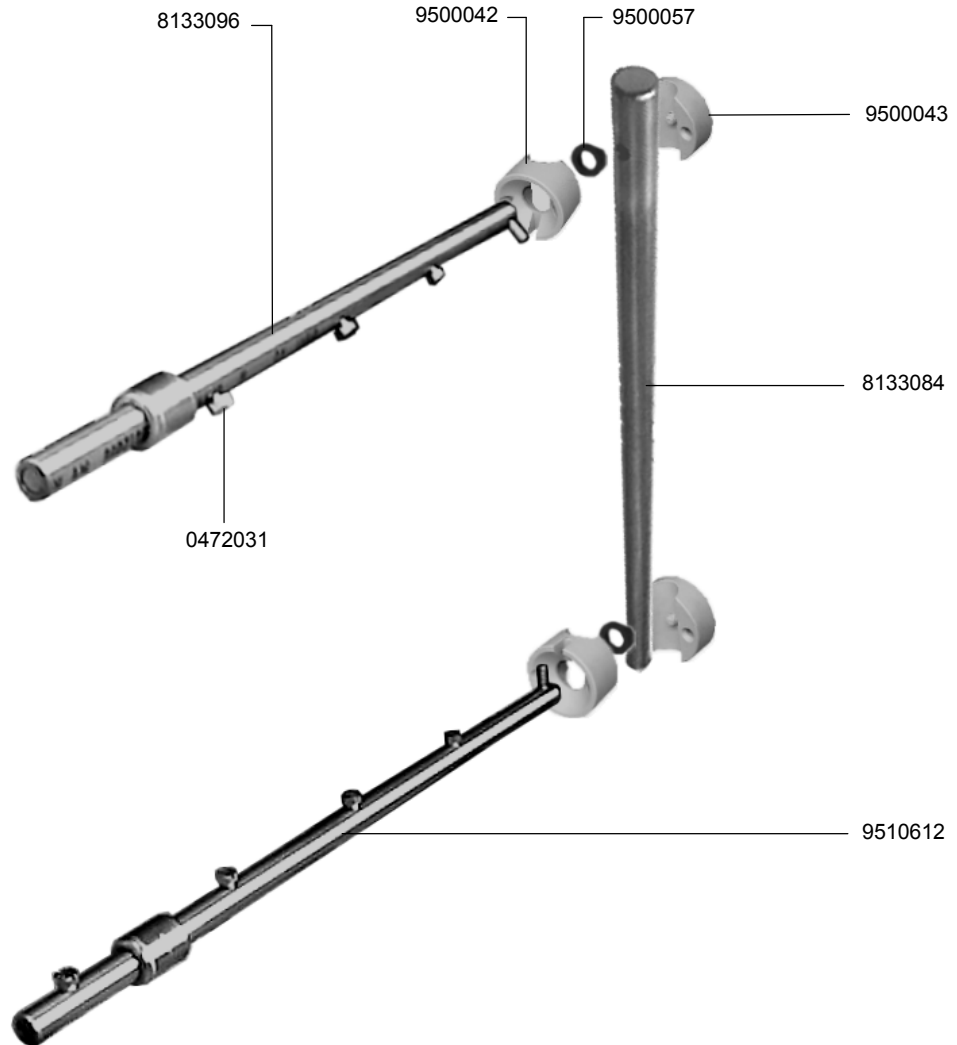

IDENT.-NR. IDENT.-NO.	BEZEICHNUNG	DESIGNATION	DESIGNATION
9510612	WASCHARM UNTEN KPL.	LOWER WASH ARM CPL.	BRAS DE LAVAGE INF. CPL.
8133084	STEIGROHR	ASCENDING PIPE	COLONNE DE LEVATION
* 9500043	KUPPLUNG RÜCKTEIL	CLUTCH BACK PART	ACCOUPEMENT ARRIERE
* 9500057	DICHTUNG	PACKING	JOINT
* 9500042	KUPPLUNG VORDERTEIL	CLUTCH FRONT PART	ACCOUPEMENT FRONTALE
8133096	WASCHARM OBEN KPL.	UPPER WASH ARM CPL.	BRAS DE LAVAGE SUP. CPL.
* 0472031	DÜSE	NOZZLE	GICLEUR

4.1 TANKABDECKSIEB-KV



4.1 TANK COVERING SIEVE-KV

4.1 TAMIS DE RECOUVREMENT DE BAC-KV

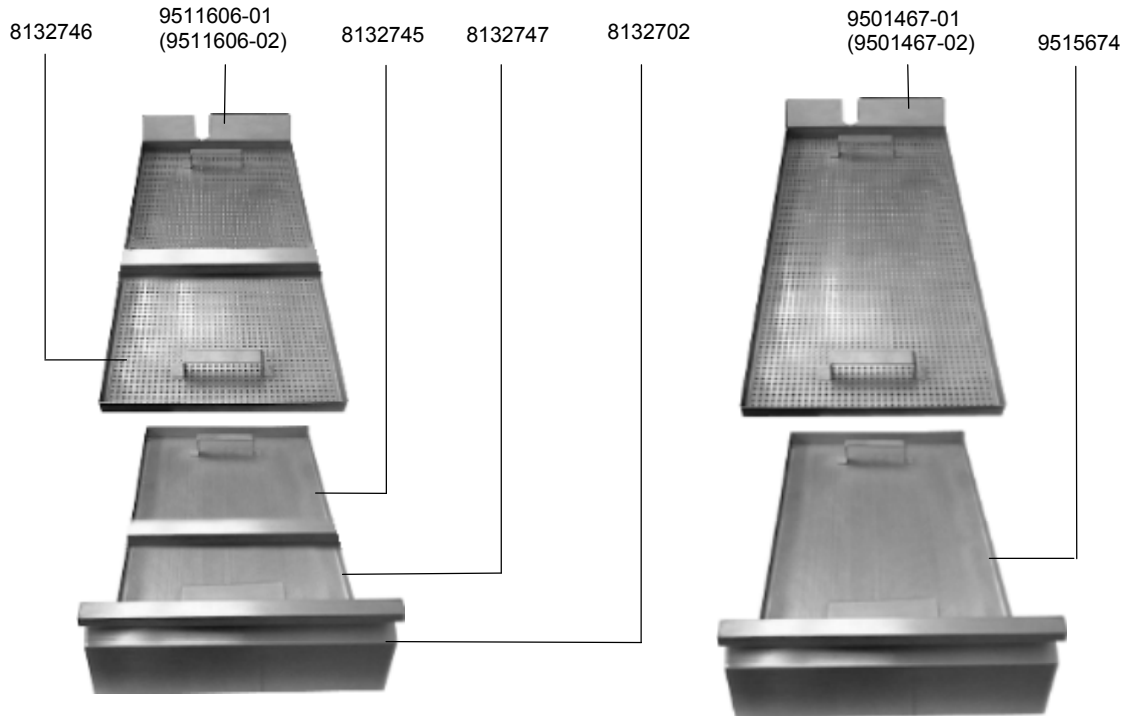

IDENT.-NR. IDENT.-NO.	BEZEICHNUNG	DESIGNATION	DESIGNATION
9515674	TANKABDECKSIEB FEIN	TANK COVERING SIEVE	TAMIS DE RECOUVREMENT DE BAC
9501467-01	TANKABDECKSIEB GROB L-R	TANK COVERING SIEVE L-R	TAMIS DE RECOUVREMENT DE BAC G-D
9501467-02	TANKABDECKSIEB GROB R-L NICHT ABGEBILDET	TANK COVERING SIEVE R-L NOT DISPLAYED	TAMIS DE RECOUVREMENT DE BAC D-G PAS D'IMAGE
8132702	BLENDE	FRONT SHEET	TOLE FRONTALE
8132747	TANKABDECKSIEB FEIN	TANK COVERING SIEVE	TAMIS DE RECOUVREMENT DE BAC
8132745	TANKABDECKSIEB FEIN	TANK COVERING SIEVE	TAMIS DE RECOUVREMENT DE BAC
9511606-01	TANKABDECKSIEB FEIN L-R	TANK COVERING SIEVE L-R	TAMIS DE RECOUVREMENT DE BAC G-D
9511606-02	TANKABDECKSIEB FEIN R-L NICHT ABGEBILDET	TANK COVERING SIEVE R-L NOT DISPLAYED	TAMIS DE RECOUVREMENT DE BAC D-G PAS D'IMAGE
8132746	TANKABDECKSIEB GROB	TANK COVERING SIEVE	TAMIS DE RECOUVREMENT DE BAC

4.2 TANKABDECKSIEB-CSS



4.2 TANK COVERING SIEVE-CSS

4.2 TAMIS DE RECOUVREMENT DE BAC-CSS

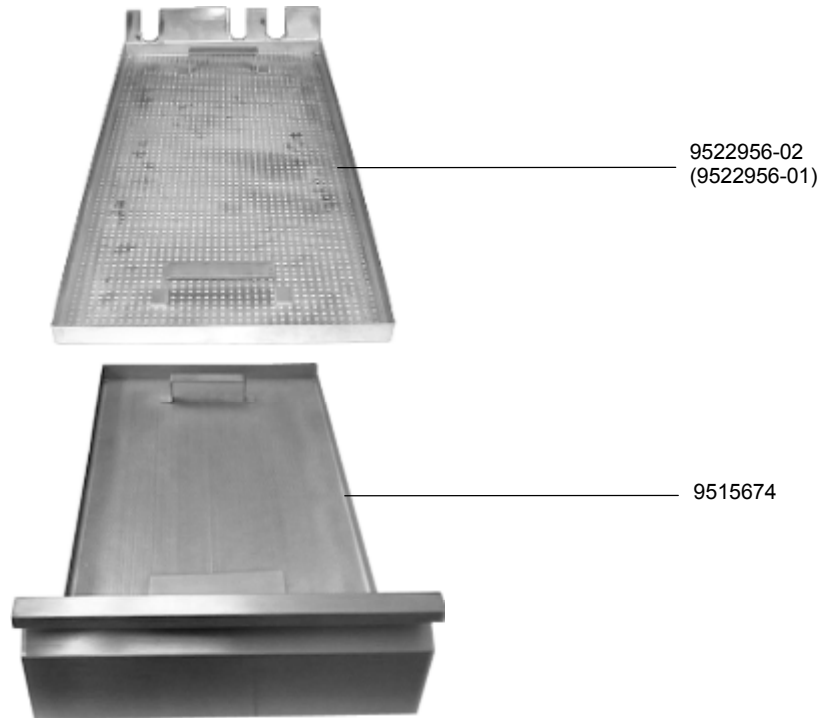

IDENT.-NR. IDENT.-NO.	BEZEICHNUNG	DESIGNATION	DESIGNATION
9515674	TANKABDECKSIEB FEIN	TANK COVERING SIEVE	TAMIS DE RECOUVREMENT DE BAC
9522956-01	TANKABDECKSIEB GROB L-R NICHT ABGEBILDET	TANK COVERING SIEVE L-R NOT DISPLAYED	TAMIS DE RECOUVREMENT DE BAC G-D PAS D'IMAGE
9522956-02	TANKABDECKSIEB GROB R-L	TANK COVERING SIEVE R-L	TAMIS DE RECOUVREMENT DE BAC D-G

4.3 TANKABDECKSIEB



4.3 TANK COVERING SIEVE

4.3 TAMIS DE RECOUVREMENT DE BAC

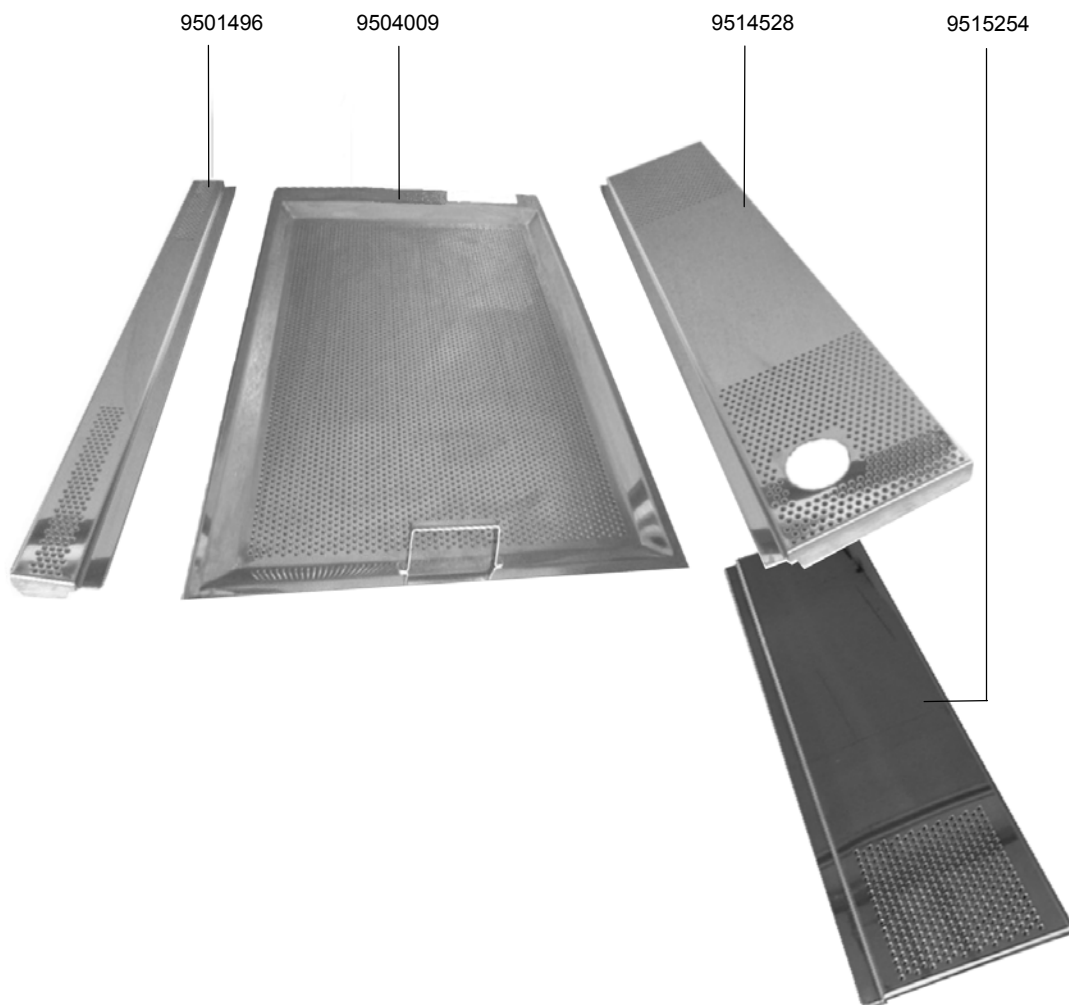

IDENT.-NR. IDENT.-NO.	BEZEICHNUNG	DESIGNATION	DESIGNATION
9515254	SIEBAUFLAGE SEITLICH	SIEVE SUPPORT	SUPPORT DE TAMIS
9514528	SIEBAUFLAGE SEITLICH	SIEVE SUPPORT	SUPPORT DE TAMIS
9504009	TANKABDECKSIEB	TANK COVERING SIEVE	TAMIS DE RECOUVREMENT DE BAC
9501496	SIEBAUFLAGE SEITLICH	SIEVE SUPPORT	SUPPORT DE TAMIS

4.4 TANKABDECKSIEB



4.4 TANK COVERING SIEVE

4.4 TAMIS DE RECOUVREMENT DE BAC

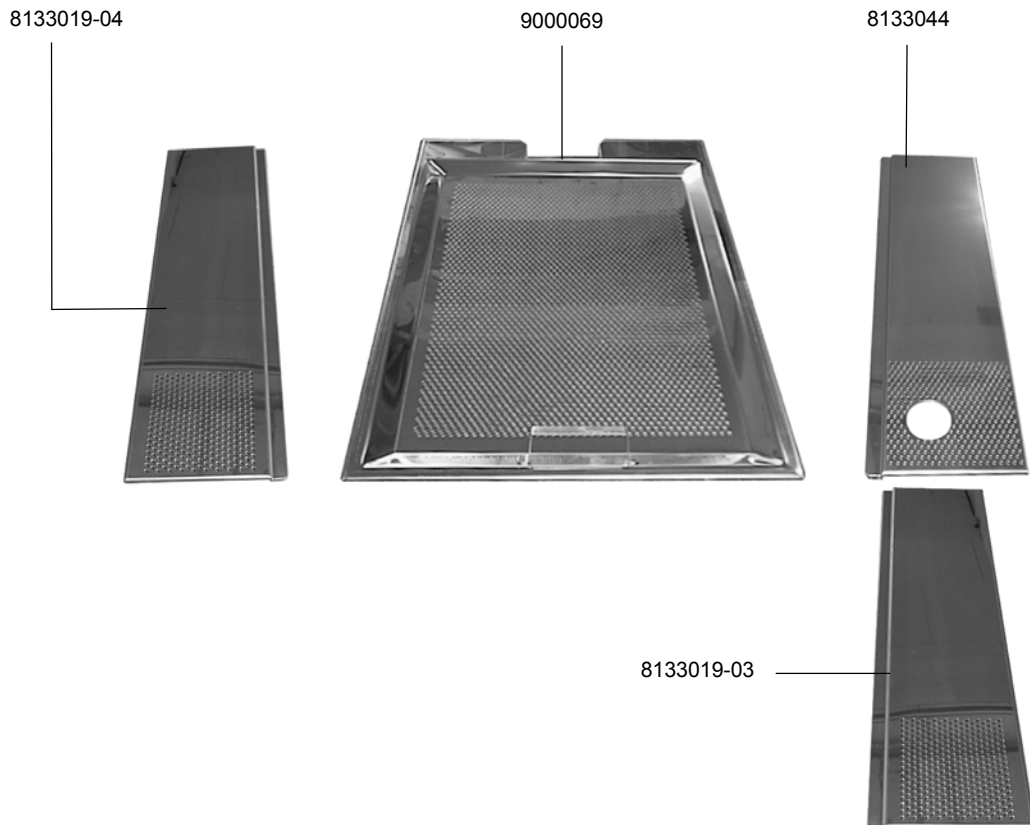

IDENT.-NR. IDENT.-NO.	BEZEICHNUNG	DESIGNATION	DESIGNATION
8133044	SIEBAUFLAGE SEITLICH	SIEVE SUPPORT	SUPPORT DE TAMIS
9000069	TANKABDECKSIEB	TANK COVERING SIEVE	TAMIS DE RECOUVREMENT DE BAC
8133019-03	SIEBAUFLAGE SEITLICH	SIEVE SUPPORT	SUPPORT DE TAMIS
8133019-04	SIEBAUFLAGE SEITLICH	SIEVE SUPPORT	SUPPORT DE TAMIS

4.5 TANKABDECKSIEB



4.5 TANK COVERING SIEVE

4.5 TAMIS DE RECOUVREMENT DE BAC

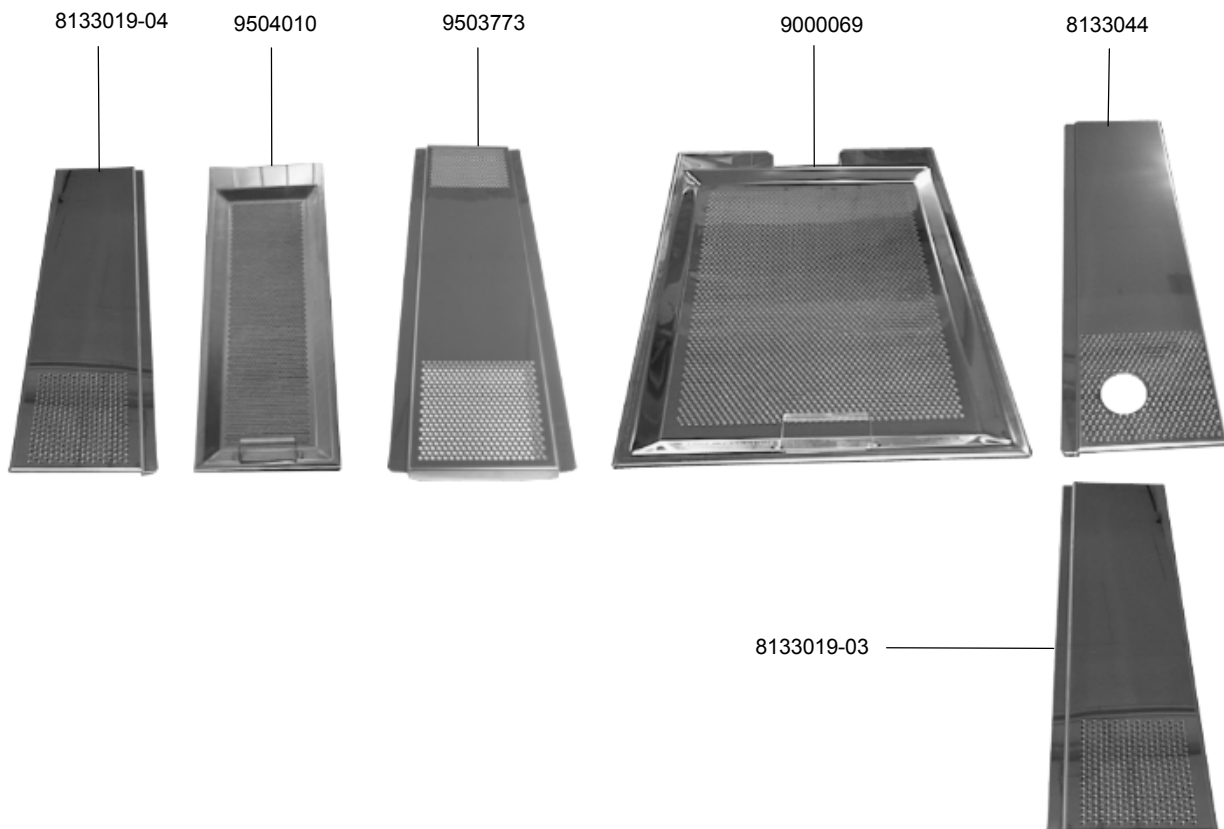

IDENT.-NR. IDENT.-NO.	BEZEICHNUNG	DESIGNATION	DESIGNATION
8133044	SIEBAUFLAGE SEITLICH	SIEVE SUPPORT	SUPPORT DE TAMIS
9000069	TANKABDECKSIEB	TANK COVERING SIEVE	TAMIS DE RECOUVREMENT DE BAC
9503773	SIEBAUFLAGE MITTIG	SIEVE SUPPORT	SUPPORT DE TAMIS
9504010	TANKABDECKSIEB	TANK COVERING SIEVE	TAMIS DE RECOUVREMENT DE BAC
8133019-03	SIEBAUFLAGE SEITLICH	SIEVE SUPPORT	SUPPORT DE TAMIS
8133019-04	SIEBAUFLAGE SEITLICH	SIEVE SUPPORT	SUPPORT DE TAMIS

5.1 TANKABLAUF

5.1 TANK DRAIN

5.1 VIDANGE DE BAC



8132739

IDENT.-NR. IDENT.-NO.	BEZEICHNUNG	DESIGNATION	DESIGNATION
--------------------------	-------------	-------------	-------------

8132739

ABLAUF

DRAIN

VIDANGE

5.2 TANKABLAUF



5.2 TANK DRAIN

5.2 VIDANGE DE BAC



9523271

IDENT.-NR. IDENT.-NO.	BEZEICHNUNG	DESIGNATION	DESIGNATION
--------------------------	-------------	-------------	-------------

9523271

ABLAUF

DRAIN

VIDANGE

5.3 TANKABLAUF

5.3 TANK DRAIN

5.3 VIDANGE DE BAC

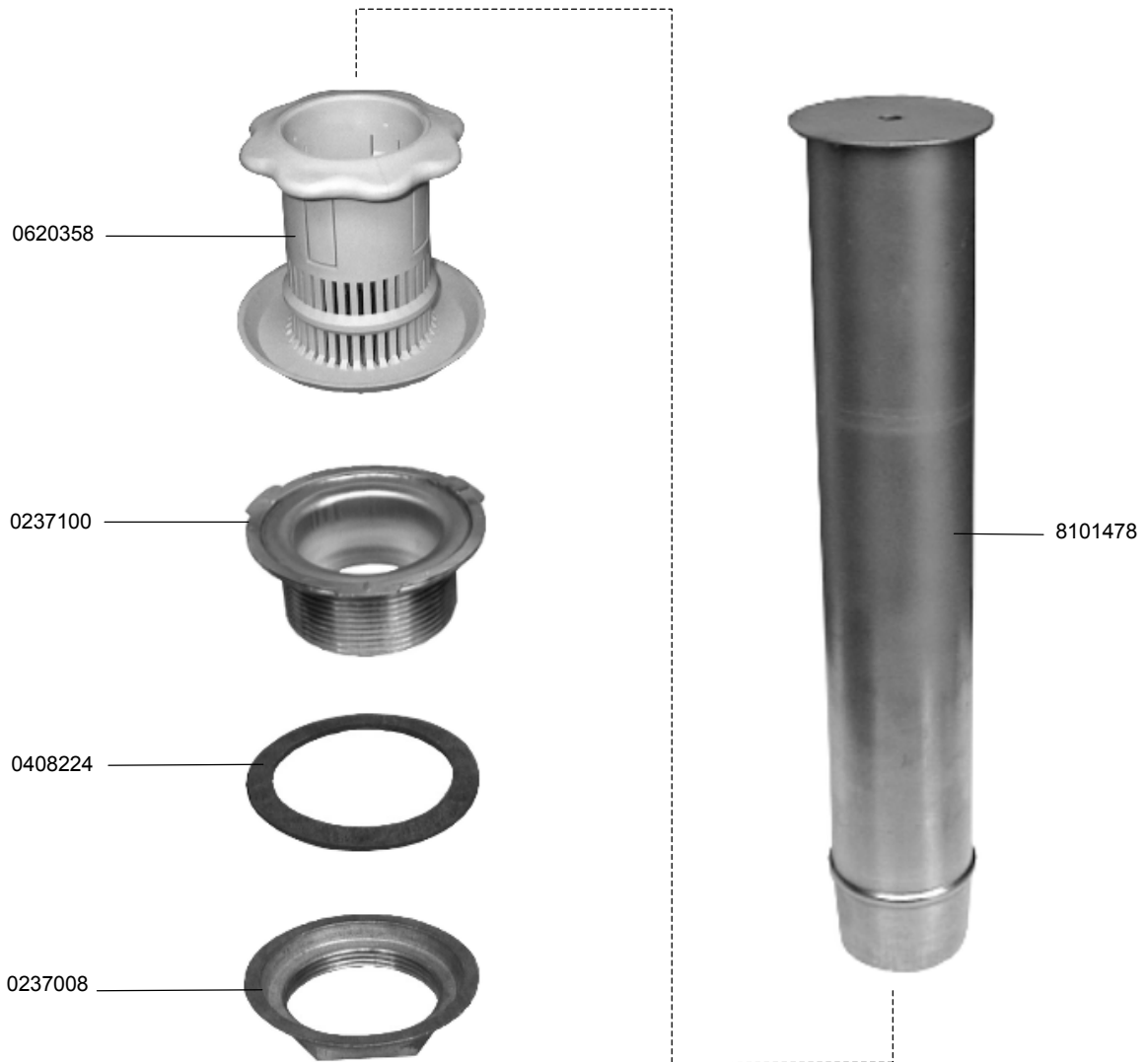

IDENT.-NR. IDENT.-NO.	BEZEICHNUNG	DESIGNATION	DESIGNATION
* 8101478	TRICHTERSTANDROHR	FUNNEL STAND PIPE	TROP-PLEIN ANTONNOIR
* 0620358	SIEB FUER STANDROHR K 363	SIEVE F. DRAIN PLUG K 363	TAMIS P. TUYAU DE VIDANGE K 363
0237100	ABLAUF G 2" KOMPLETT	DRAIN 2" 434131240	VIDANGE 2"
0408224	GUMMIDICHTUNG 78X60X2	RUBBER PACKING 78X60X2	JOINT EN CAOUTCHOUC 78X60X2
0237008	STANDR.VENT.-MUTTER 9942 2" X 88 MM MS.	NUT. NO. 9942 MS2 " X 88 MM	ECROU NO. 9942 MS 2 " X 88 MM

5.4 TANKABLAUF

5.4 TANK DRAIN

5.4 VIDANGE DE BAC

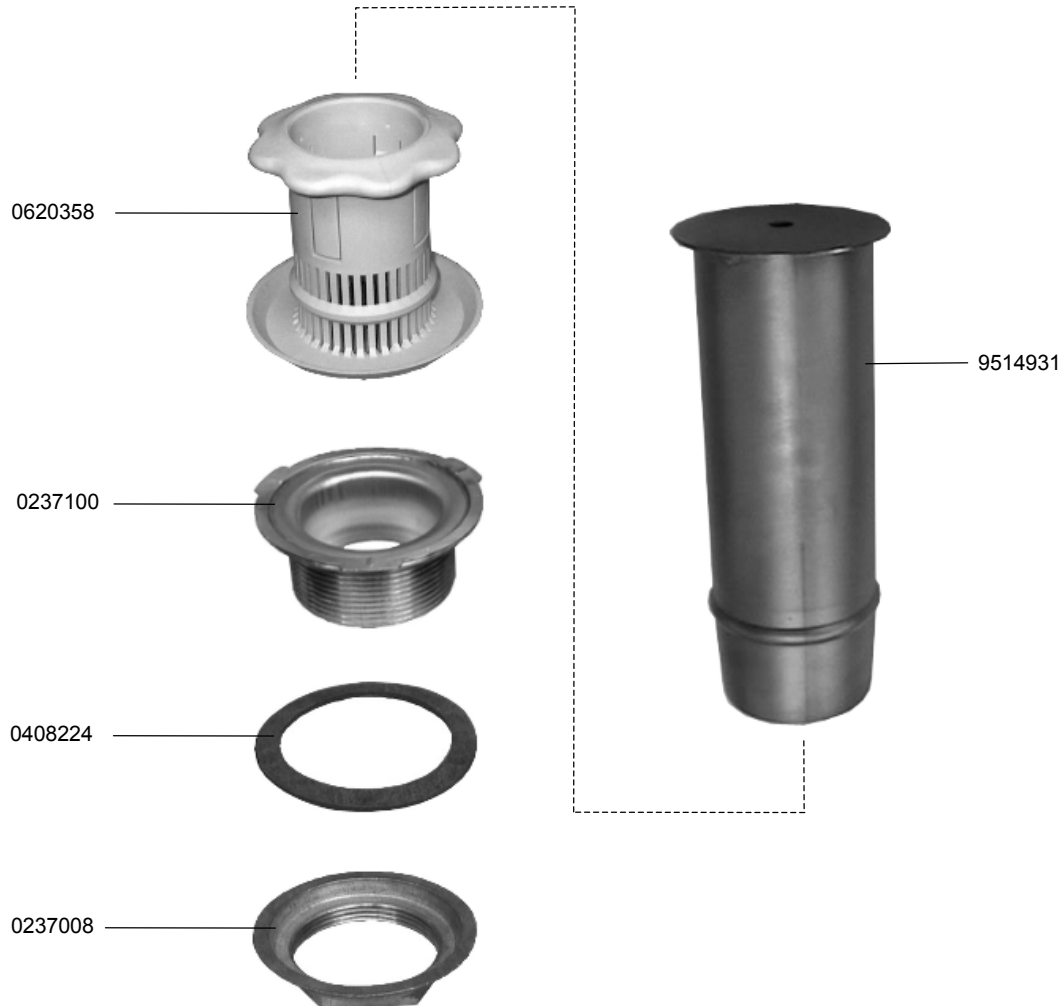

IDENT.-NR. IDENT.-NO.	BEZEICHNUNG	DESIGNATION	DESIGNATION
* 9514931	TRICHTERSTANDROHR	FUNNEL STAND PIPE	TROP-PLEIN ANTONNOIR
* 0620358	SIEB FUER STANDROHR K 363	SIEVE F. DRAIN PLUG K 363	TAMIS P. TUYAU DE VIDANGE K 363
0237100	ABLAUF G 2" KOMPLETT	DRAIN 2" 434131240	VIDANGE 2"
0408224	GUMMIDICHTUNG 78X60X2	RUBBER PACKING 78X60X2	JOINT EN CAOUTCHOUC 78X60X2
0237008	STANDR.VENT.-MUTTER 9942 2" X 88 MM MS.	NUT. NO. 9942 MS2 " X 88 MM	ECROU NO. 9942 MS 2 " X 88 MM

6.1 WASCHPUMPE KV



6.1 WASHPUMP KV

6.1 POMPE DE LAVAGE KV

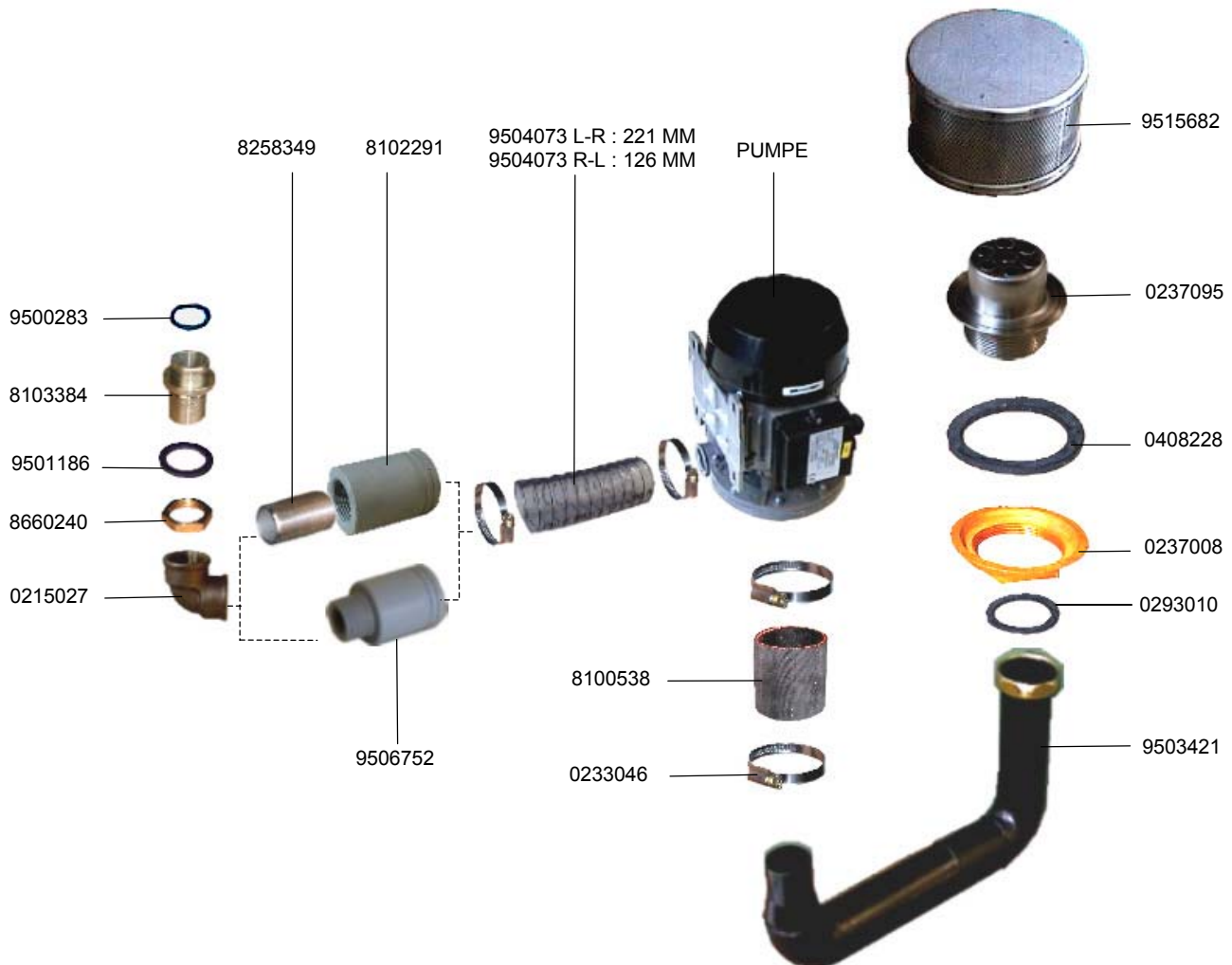

6.1 WASCHPUMPE KV



6.1 WASHPUMP KV

6.1 POMPE DE LAVAGE KV

IDENT.-NR. IDENT.-NO.	BEZEICHNUNG	DESIGNATION	DESIGNATION
9503421	ANSAUGSTUTZEN	SUCTION PORT	MANCHON DE ASPIRATION
0293010	DICHTUNG	PACKING	JOINT
0237008	MUTTER 2"	NUT 2"	ECROU 2"
0408228	DICHTUNG	PACKING	JOINT
0237095	ANSAUGSIEB	SUCTION SIEVE	FILTRE DE ASPIRATION
9515682	ANSAUGSIEB	SUCTION SIEVE	FILTRE DE ASPIRATION
PUMPE	SIEHE ELEKTROSCHALTPLAN	SEE ELECTRIC WIRING DIAGRAMM	VOIR SCHEMA ELECTRIQUE
9504073	SCHLAUCH L-R, 221 MM	HOSE L-R, 221 MM	TUYAU G-D, 221 MM
9504073	SCHLAUCH R-L, 126 MM	HOSE R-L, 126 MM	TUYAU D-G, 126 MM
8102291	NIPPEL	NIPPLE	NIPPLE
8258349	GEWINDENIPPEL	NIPPLE	NIPPLE
9500283	O-RING	O-RING	BAGUE
8103384	TANKDURCHFÜHRUNG	TANKTHROUGH-LEAD	TRAVERSEE DU BAC
9501186	DICHTUNG	PACKING	JOINT
8660240	MUTTER 3/4"	NUT 3/4"	ECROU 3/4"
0215027	WINKEL 3/4"	ANGLE 3/4"	ANGLE 3/4"
9506752	VERBINDUNGSTEIL	CONNECTION PART	PIECE DE CONNEXION
8100538	SCHLAUCH	HOSE	TUYAU
0233046	SCHLAUCHKLEMME 32-50	HOSE WIRE CLAMP 32 50	COLLIER DE SERRAGE 32-50

6.2 WASCHPUMPE CSS



6.2 WASH PUMP CSS

6.2 POMPE DE LAVAGE CSS

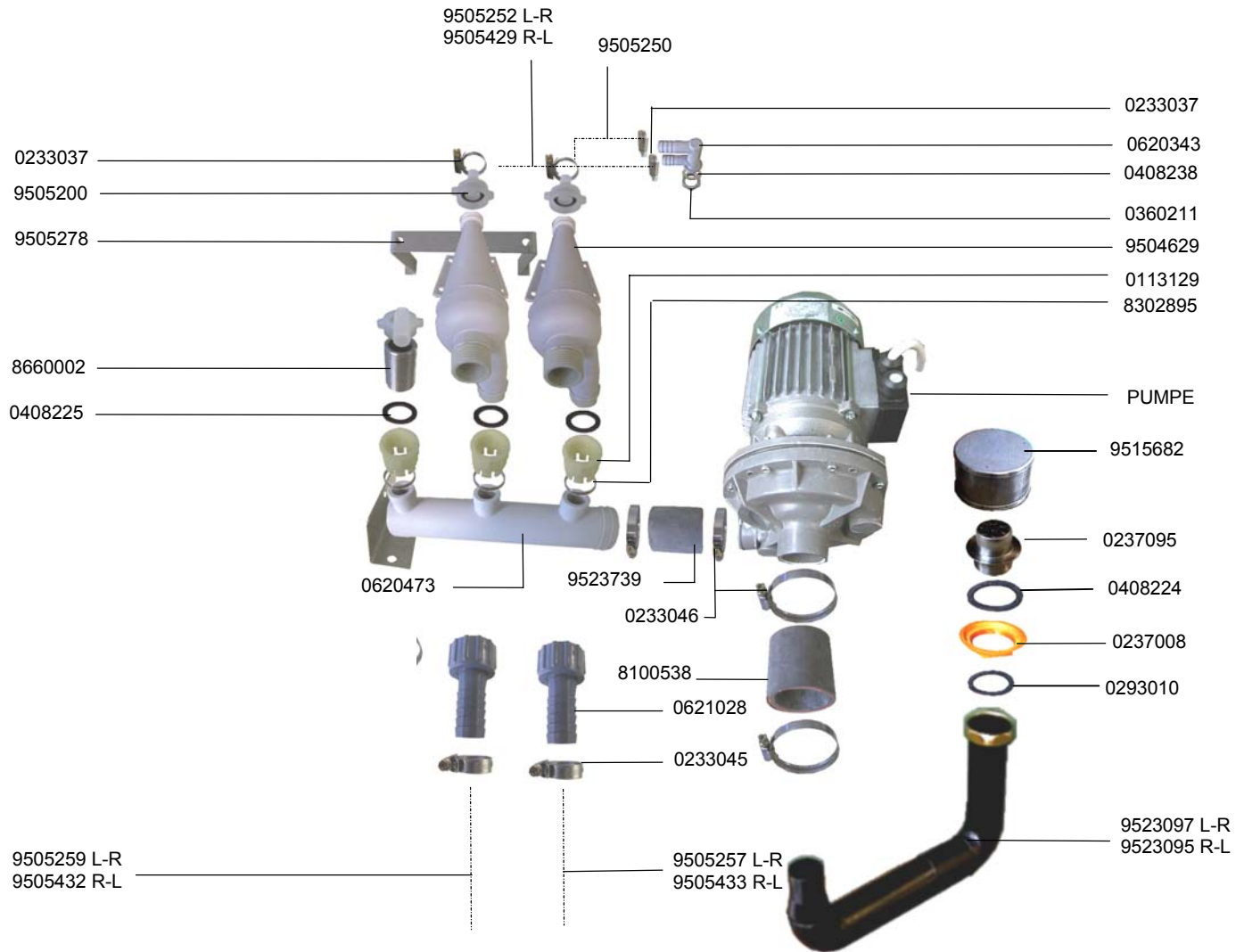

6.2 WASCHPUMPE CSS



6.2 WASH PUMP CSS

6.2 POMPE DE LAVAGE CSS

IDENT.-NR. IDENT.-NO.	BEZEICHNUNG	DESIGNATION	DESIGNATION
9523097	ANSAUGSTUTZEN L-R	SUCTION PORT L-R	MANCHON DE ASPIRATION G-D
9523095	ANSAUGSTUTZEN R-L	SUCTION PORT R-L	MANCHON DE ASPIRATION D-G
0293010	DICHTUNG	PACKING	JOINT
0237008	MUTTER 2"	NUT 2"	ECROU 2"
0408224	DICHTUNG	PACKING	JOINT
0237095	ANSAUGSIEB	SUCTION SIEVE	FILTRE DE ASPIRATION
9515682	ANSAUGSIEB	SUCTION SIEVE	FILTRE DE ASPIRATION
PUMPE	SIEHE ELEKTROSCHALTPLAN	SEE ELECTRIC WIRING DIAGRAM	VOIR SCHEMA ELECTRIQUE
8302895	HALTERING	SUPPORT RING	BAGUE DE SUPPORT
0113129	ANSCHLUSSTÜCK	CONNECTION PIECE	PIECE DE CONNEXION
* 9504629	ZYKLONGEHÄUSE	CYCLONE HOUSING	CORPS CYCLONE
0360211	MUTTER	NUT	ECROU
0408238	DICHTUNG	PACKING	JOINT
0620343	SCHLAUCHANSCHLUSS	HOSE CONNECTION	CONNEXION DE TUYAU
0233037	SCHLAUCHKLEMME	HOSE WIRE CLAMP	COLLIER DE SERRAGE
9505250	SCHLAUCH	HOSE	TUYAU
9505252	SCHLAUCH L-R	HOSE L-R	TUYAU G-D
9505429	SCHLAUCH R-L	HOSE R-L	TUYAU D-G
9505200	ANSCHLUSSTÜCK	CONNECTION PIECE	PIECE DE CONNEXION
9505278	HALTEBÜGEL	SUPPORT	SUPPORT
8660002	STOPFEN	BOLT	BOULON
* 0408225	DICHTUNG	PACKING	JOINT
9505259	SCHLAUCH L-R	HOSE L-R	TUYAU G-D
9505432	SCHLAUCH R-L	HOSE R-L	TUYAU D-G
0620473	VERTEILERROHR	DISTRIBUTING PIPE	TUYEAU DISTRIBUTEUR
9523739	SCHLAUCH	HOSE	TUYAU
0233046	SCHLAUCHKLEMME	HOSE WIRE CLAMP	COLLIER DE SERRAGE
8100538	SCHLAUCH	HOSE	TUYAU
0621028	ÜBERGANGSSTÜCK	CONNECTOR	PIECE DE RACCORDEMENT
0233045	SCHLAUCHKLEMME	HOSE WIRE CLAMP	COLLIER DE SERRAGE
9505257	SCHLAUCH L-R	HOSE L-R	TUYAU G-D
9505433	SCHLAUCH R-L	HOSE R-L	TUYAU D-G
0501091	PUMPENGEHÄUSE	PUMP HOUSING	CORPS DE POMPE
* 9514646	PUMPENLAUFRAD	PUMP WHEEL	ROUE DE POMPE
V 0501095	GLEITRINGDICHTUNG	SLIDING SEAL	JOINT AXIAL
0501094	DICHTUNG	PACKING	JOINT
0501108	PUMPENDECKEL	PUMP LID	COUVERCLE DE POMPE
0501098	VENTILATORFLÜGEL	FAN WHEEL	ROUE VENTILATEUR
9518714	LÜFTERHAUBE	FAN COWL	COPOTAGE DE VENTILATEUR

6.4 WASCHPUMPE 1,7KW CRNI, 50HZ



6.4 WASH PUMP 1,7KW CRNI, 50HZ

6.4 POMPE DE LAVAGE 1,7KW CRNI, 50HZ

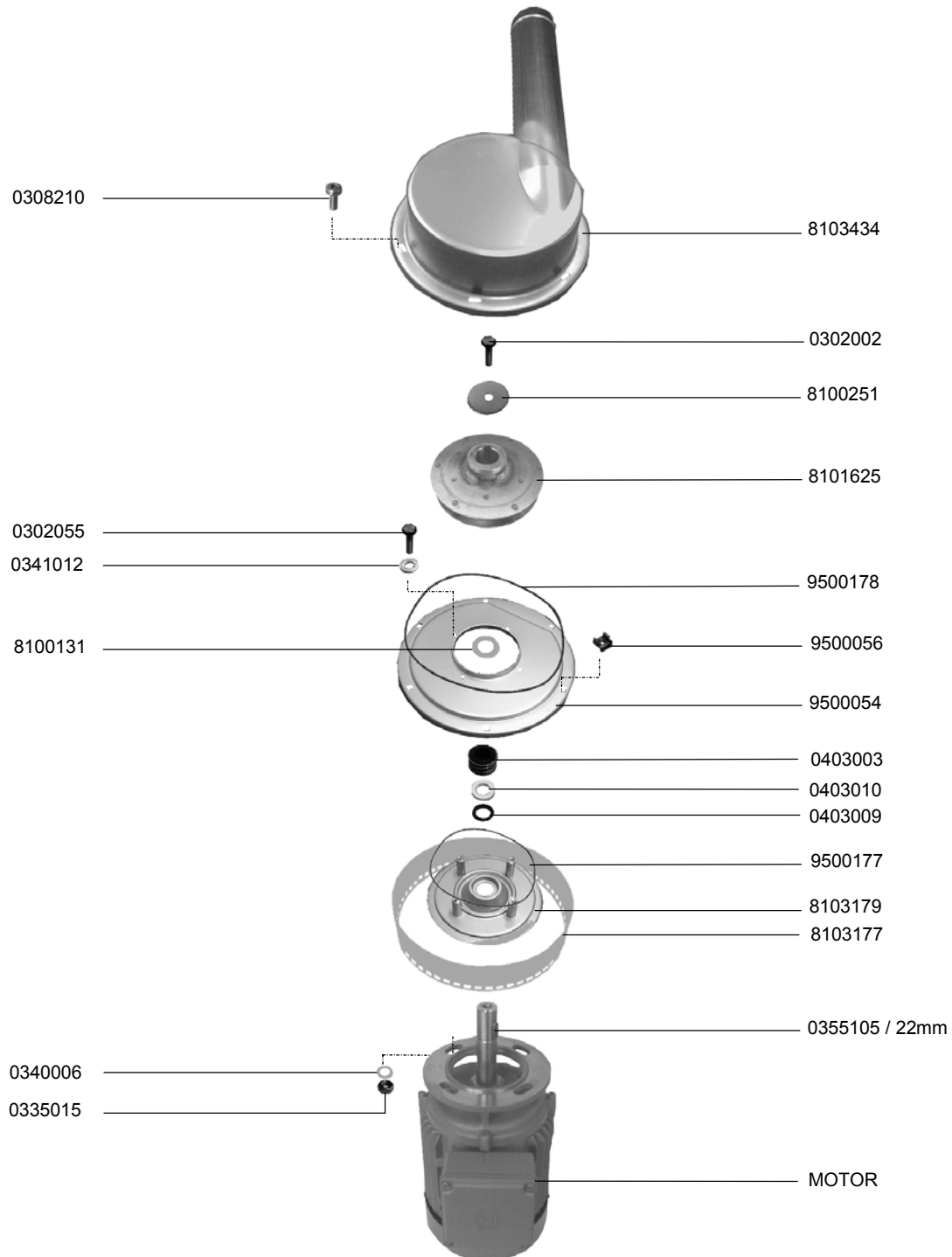

6.4 WASCHPUMPE 1,7KW CRNI, 50HZ



6.4 WASH PUMP 1,7KW CRNI, 50HZ

6.4 POMPE DE LAVAGE 1,7KW CRNI, 50HZ

IDENT.-NR. IDENT.-NO.	BEZEICHNUNG	DESIGNATION	DESIGNATION
MOTOR	SIEHE ELEKTROSCHALTPLAN	SEE ELECTRIC WIRING DIAGRAM	VOIR SCHEMA ELECTRIQUE
* 0355105	PASSFEDER A 8X7X22	FEATHER KEY A 8X7X22	RESSORT D'AJUSTAGE A 8X7X22
8103177	ANSAUGSIEB	SUCTION SIEVE	FILTRE D'ASPIRATION
8103179	MOTORTRÄGER	MOTOR SUPPORT	SUPPORT DE MOTEUR
* 9500177	RUNDDICHTRING 70°	GASKET 70°	JOINT 70°
V 0403009	GLEITR.-MANSCHETTE WINKEL 30X40X7 480000008	COLLAR PERBUNAN 30X40X7 480 000 008	MANCHETTE PEBUNAN 30X40X7 480 000 008
V 0403010	GLEITRING KERAMIK 25,9X38X8	SLIDING SEAL CERAMICS 25X38X8	JOINT AXIAL CERAMIQUE 25X38X8
V 0403003	GLEITRINGDICHTUNG VITON 25X44X20	SLIDING SEAL 25X44X20	JOINT AXIAL 25X44X20
9500054	PUMPENBODEN	PUMP BASE	FOND DE POMPE
9500056	KÄFIGMUTTER M6 1,2-1,6	NUT M6 1,2-1,6	ECROU M6 1,2-1,6
* 9500178	RUNDDICHTRING 70°	GASKET 70°	JOINT 70°
* 8101625	PUMPENRAD 1,7KW Ø120X49 1.4301	IMPELLER 1,7KW Ø120X49 1.4301	ROUE DE POMPE 1,7KW Ø120X49 1.4301
8100251	U-SCHEIBE Ø34X7X2 1.4301	FRONT DISC Ø34X7X2 1.4301	RONDELLE Ø34X7X2 1.4301
0302002	SKT.-SCHRAUBE M6X20	HEXAGON SCREW	VIS A 6 PANS
8103434	PUMPENDECKEL KOMPL.	PUMP LID CPL.	COUVERCLE DE POMPE CPL.
0308210	SKT.-SCHRAUBE M6X10	SCREW M6 X 10,	VIS M 6 X 10,
0302055	SKT.-SCHRAUBE M6X12	HEXAGON SCREW M6 X 12 MM 1.4301	VIS A 6 PANS DIN 933 M6 X 12 MM 1.4301
0341012	FEDERRING 6	SPRING RING 6	RESSORT 6
8100131	U-SCHEIBE Ø38XØ24,1X1 1.4301	SUPPORT DISC Ø38XØ24,1X1 1.4301	RONDELLE Ø38XØ24,1X1 1.4301
0340006	U-SCHEIBE MS. VERN. Ø18XØ8,4X2	WASHER BRASS NICKELLED Ø18XØ8,4X2	RONDELLE EN LAITON NICKELE Ø18XØ8,4X2
0335015	SKT.-MUTTER M8 1.4301	HEXAGON NUT M8 1.4301	ECROU A 6 PANS M8 1.4301

6.5 WASCHPUMPE - PUMPENKLARSPÜLUNG



6.5 WASHPUMP - PUMP FINAL RINSE

6.5 POMPE DE LAVAGE - RINCAGE FINAL A POMPE

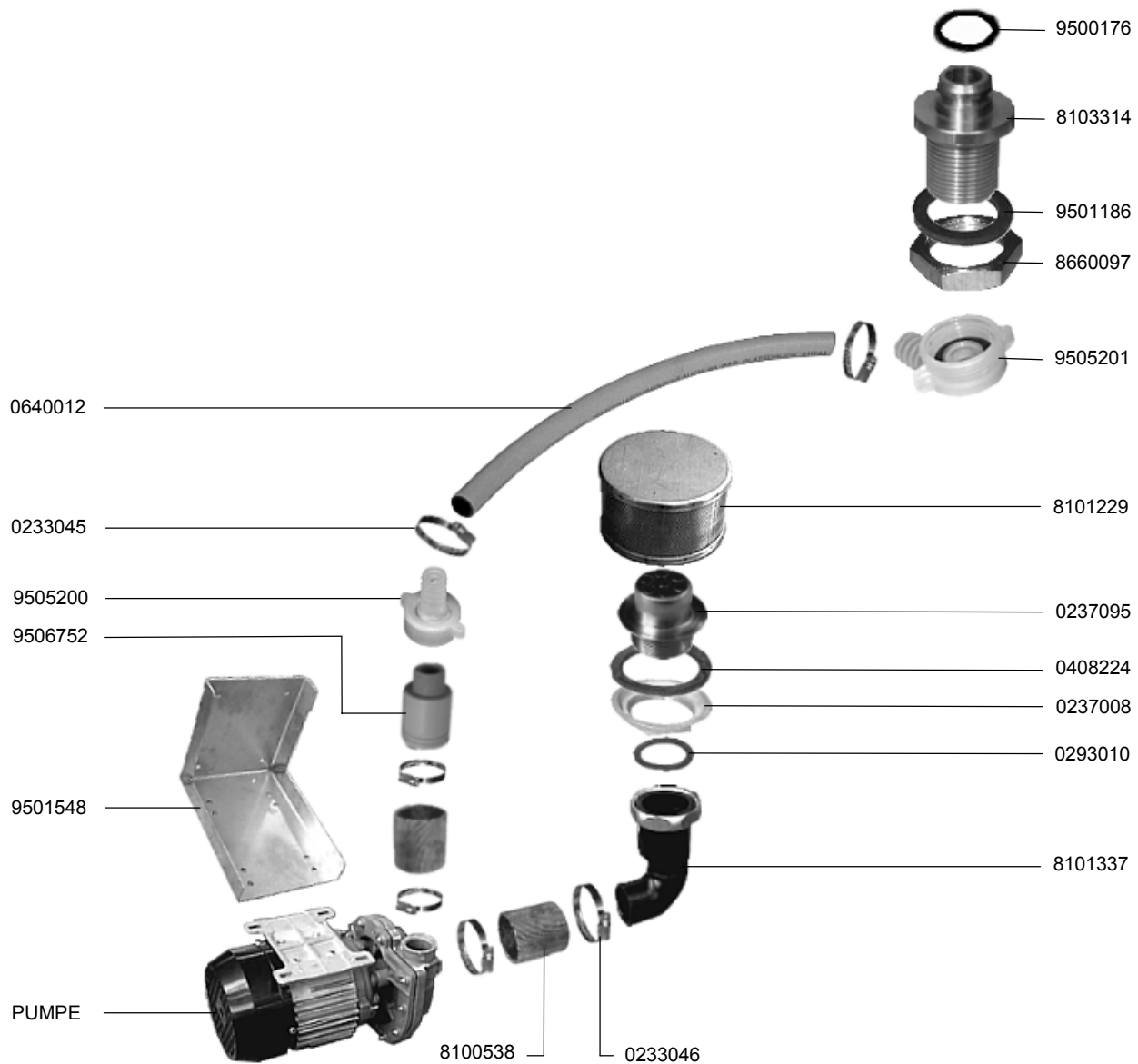

6.5 WASCHPUMPE - PUMPENKLARSPÜLUNG



6.5 WASHPUMP - PUMP FINAL RINSE

6.5 POMPE DE LAVAGE - RINCAGE FINAL A POMPE

IDENT.-NR. IDENT.-NO.	BEZEICHNUNG	DESIGNATION	DESIGNATION
8101337	ANSAUGSTUTZEN	SUCTION PORT	MANCHON DE ASPIRATION
0293010	DICHTUNG	PACKING	JOINT
0237008	MUTTER 2"	NUT 2"	ECROU 2"
0408224	DICHTUNG	PACKING	JOINT
0237095	ANSAUGSIEB	SUCTION SIEVE	FILTRE DE ASPIRATION
8101229	ANSAUGSIEB	SUCTION SIEVE	FILTRE DE ASPIRATION
9505201	ANSCHLUSWINKEL	CONNECTION ANGLE	ANGLE DE CONNEXION
8660097	MUTTER 3/4"	NUT 3/4"	ECROU 3/4"
9501186	DICHTUNG	PACKING	JOINT
8103314	TANKDURCHFÜHRUNG	TANKTHROUGH-LEAD	TRAVERSEE DU BAC
* 9500176	O-RING	O-RING	BAGUE
0640012	SCHLAUCH	HOSE	TUYAU
0233045	SCHLAUCHKLEMME 20-32	HOSE WIRE CLAMP 20-32	COLLIER DE SERRAGE 20-32
9505200	ANSCHLUSSTÜCK	CONNECTION PART	PIECE DE CONNEXION
9506752	VERBINDUNGSTEIL	CONNECTION PART	PIECE DE CONNEXION
9501548	KONSOLE	CONSOLE	CONSOLE
PUMPE	SIEHE ELEKTROSCHALTPLAN	SEE ELECTRIC WIRING DIAGRAM	VOIR SCHEMA ELECTRIQUE
8100538	SCHLAUCH	HOSE	TUYAU
0233046	SCHLAUCHKLEMME 32-50	HOSE WIRE CLAMP 32 50	COLLIER DE SERRAGE 32-50

6.6 WASCHPUMPE V 750



6.6 WASHPUMP V 750

6.6 POMPE DE LAVAGE V 750

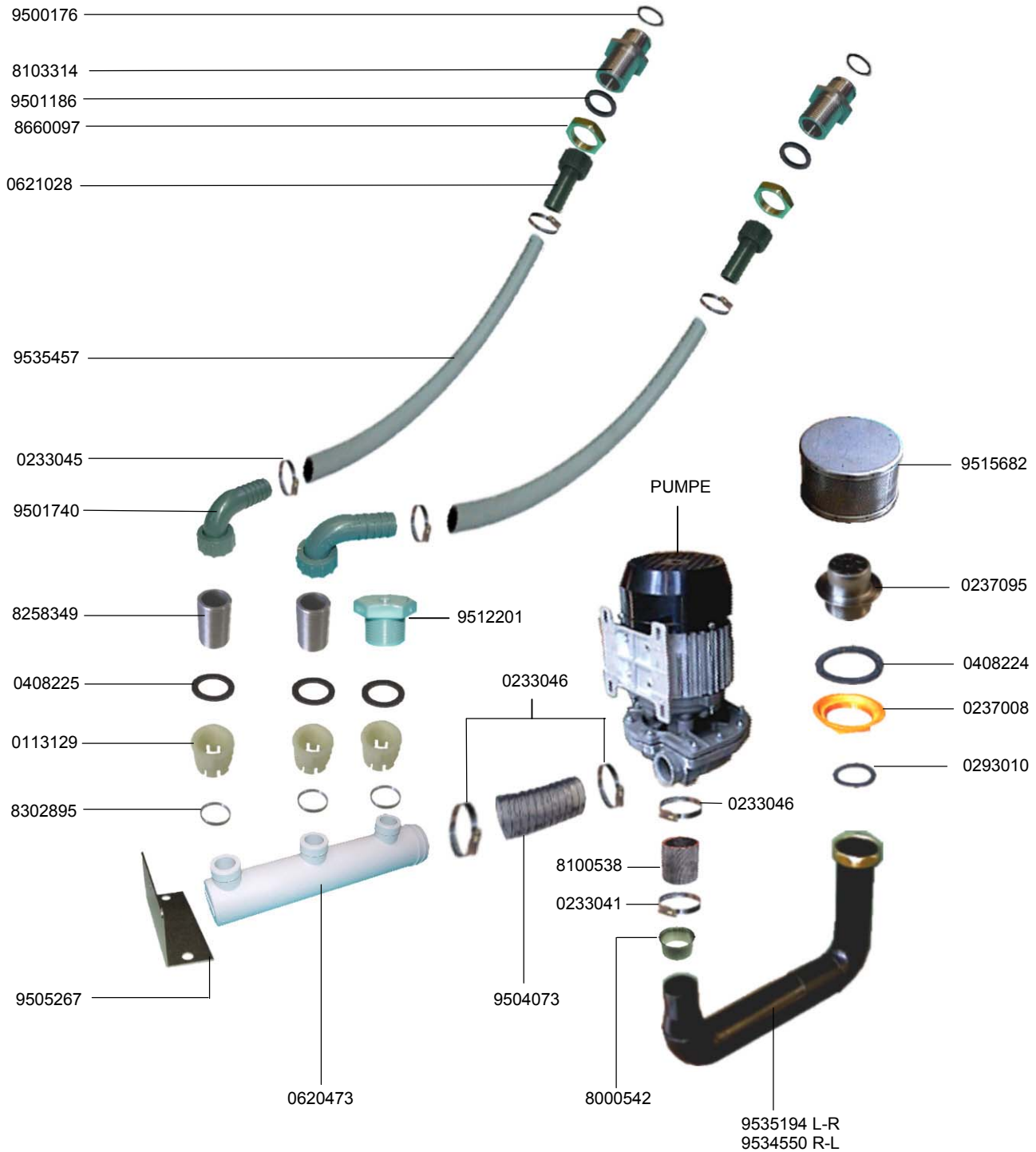

6.6 WASCHPUMPE V 750



6.6 WASHPUMP V 750

6.6 POMPE DE LAVAGE V 750

IDENT.-NR. IDENT.-NO.	BEZEICHNUNG	DESIGNATION	DESIGNATION
9535194	ANSAUGSTUTZEN L-R	SUCTION PORT L-R	MANCHON DE ASPIRATION G-D
9534550	ANSAUGSTUTZEN R-L	SUCTION PORT R-L	MANCHON DE ASPIRATION D-G
0293010	DICHTUNG	PACKING	JOINT
0237008	MUTTER 2"	NUT 2"	ECROU 2"
0408224	DICHTUNG	PACKING	JOINT
0237095	ANSAUGSIEB	SUCTION SIEVE	FILTRE DE ASPIRATION
9515682	ANSAUGSIEB	SUCTION SIEVE	FILTRE DE ASPIRATION
9501740	ANSCHLUSSWINKEL	CONNECTION ANGLE	ANGLE DE CONNECTION
8660097	MUTTER 3/4"	NUT 3/4"	ECROU 3/4"
9501186	DICHTUNG	PACKING	JOINT
8103314	TANKDURCHFÜHRUNG	TANKTHROUGH-LEAD	TRAVERSEE DU BAC
* 9500176	O-RING	O-RING	BAGUE
9535457	SCHLAUCH	HOSE	TUYAU
0233045	SCHLAUCHKLEMME 20-32	HOSE WIRE CLAMP 20-32	COLLIER DE SERRAGE 20-32
0233046	SCHLAUCHKLEMME 32-50	HOSE WIRE CLAMP 32-50	COLLIER DE SERRAGE 32-50
0621028	ANSCHLUSSTÜCK	CONNECTION PIECE	PIECE DE CONNEXION
8258349	GEWINDENIPPEL	NIPPLE	NIPPLE
PUMPE	SIEHE ELEKTROSCHALTPLAN	SEE ELECTRIC WIRING DIAGRAM	VOIR SCHEMA ELECTRIQUE
8100538	SCHLAUCH	HOSE	TUYAU
0233046	SCHLAUCHKLEMME 32-50	HOSE WIRE CLAMP 32 50	COLLIER DE SERRAGE 32-50
* 0408225	DICHTUNG	PACKING	JOINT
0113129	ANSCHLUSSTÜCK	CONNECTION PIECE	PIECE DE CONNEXION
8302895	HALTERING	SUPPORT RING	BAGUE DE SUPPORT
9505267	HALTERUNG	SUPPORT	SUPPORT
0620473	VERTEILERROHR	DISTRIBUTING PIPE	TUYEAU DISTRIBUTEUR
9504073	SCHLAUCH	HOSE	TUYAU
0233041	SCHLAUCHKLEMME 40-60	HOSE WIRE CLAMP 40-60	COLLIER DE SERRAGE 40-60
9512201	STOPFEN	BOLT	BOULON
8000542	VERSTÄRKUNGSRING	SUPPORT RING	BAGUE DE SUPPORT

7 TROCKNUNG

7 DRYING

7 SECHAGE

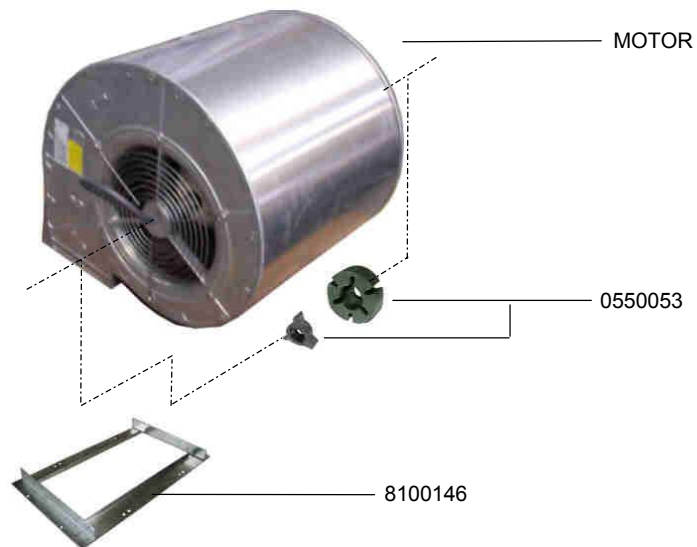

IDENT.-NR. IDENT.-NO.	BEZEICHNUNG	DESIGNATION	DESIGNATION
8100146	RAHMEN FÜR GEBLÄSE,SCHW.T 1.4301 440X250X30	FRAME FOR FAN 1.4301 440X250X30	CADRE DE VENTILATEUR 1.4301 440X250X30
MOTOR	SIEHE ELEKTROSCHALTPLAN	SEE ELECTRIC WIRING DIAGRAM	VOIR SCHEMA ELECTRIQUE
V 0550053	LAGERBUECHSE 1610-023 00273340 MIT EINSATZ	BEARING BUSH 1610-023 00273340	COUSSINET 1610-023 00273340

8.1 TÜR 500



8.1 DOOR 500

8.1 PORTE 500

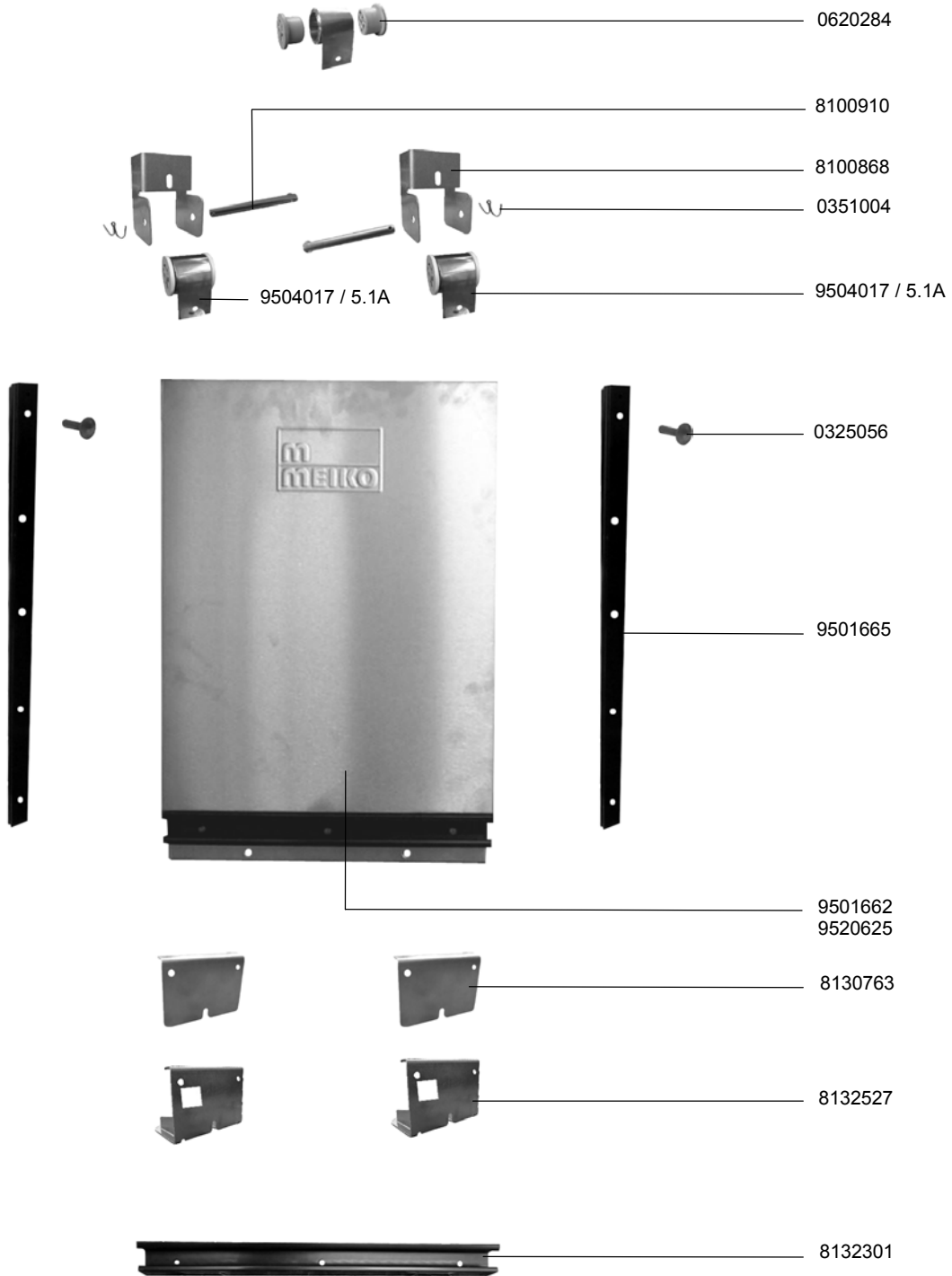

8.1 TÜR 500



8.1 DOOR 500

8.1 PORTE 500

IDENT.-NR. IDENT.-NO.	BEZEICHNUNG	DESIGNATION	DESIGNATION
8132301	TÜRGRIFFPROFIL TÜR 500MM	DOOR HANDLE PROFILE DOOR 500MM	PROFILE DE POIGNEE DE PORTE, PORTE 500MM
8132527	TÜRANSCHLAG MIT ABLAUFSCHLIESSUNG	DOOR CATCH WITH DRAIN CLOSING SYSTEM	ARRET DE PORTE AVEC SYSTEME DE FERMETURE DE VIDANGE
8130763	TÜRANSCHLAG	DOOR CATCH	ARRET DE PORTE
9501662	TÜR	DOOR	PORTE
9520625	TÜR OHNE PRÄGUNG	DOOR WITHOUT EMBOSsing	PORTE SANS ESTAMPE
9501665	FÜHRUNGSSCHIENE	GUIDE RAIL	RAIL DE GUIDAGE
0325056	SCHRAUBE M5X30	SCREW M5X30	VIS M5X30
V 9504017	ROLLFEDER 5.1A	ROLLER SPRING 5.1A	ROULEAU A TROU 5.1A
* 0351004	SPLINT 2X20	SPLIT 2X20	GOUPILLE 2X20
8100868	ROLLFEDERHALTERUNG	SCROLL SPRING SUPPORT	SUPPORT POUR RESSORT A CROSSE
8100910	LAGERBOLZEN KURZ Ø8X78	BOLT SHORT Ø8X78	BOULON Ø8X78
* 0620284	LAGERROLLE ½"	SUPPORT ROLL ½"	ROLEAU DE SUPPORT ½"

8.2 TÜR 800



8.2 DOOR 800

8.2 PORTE 800

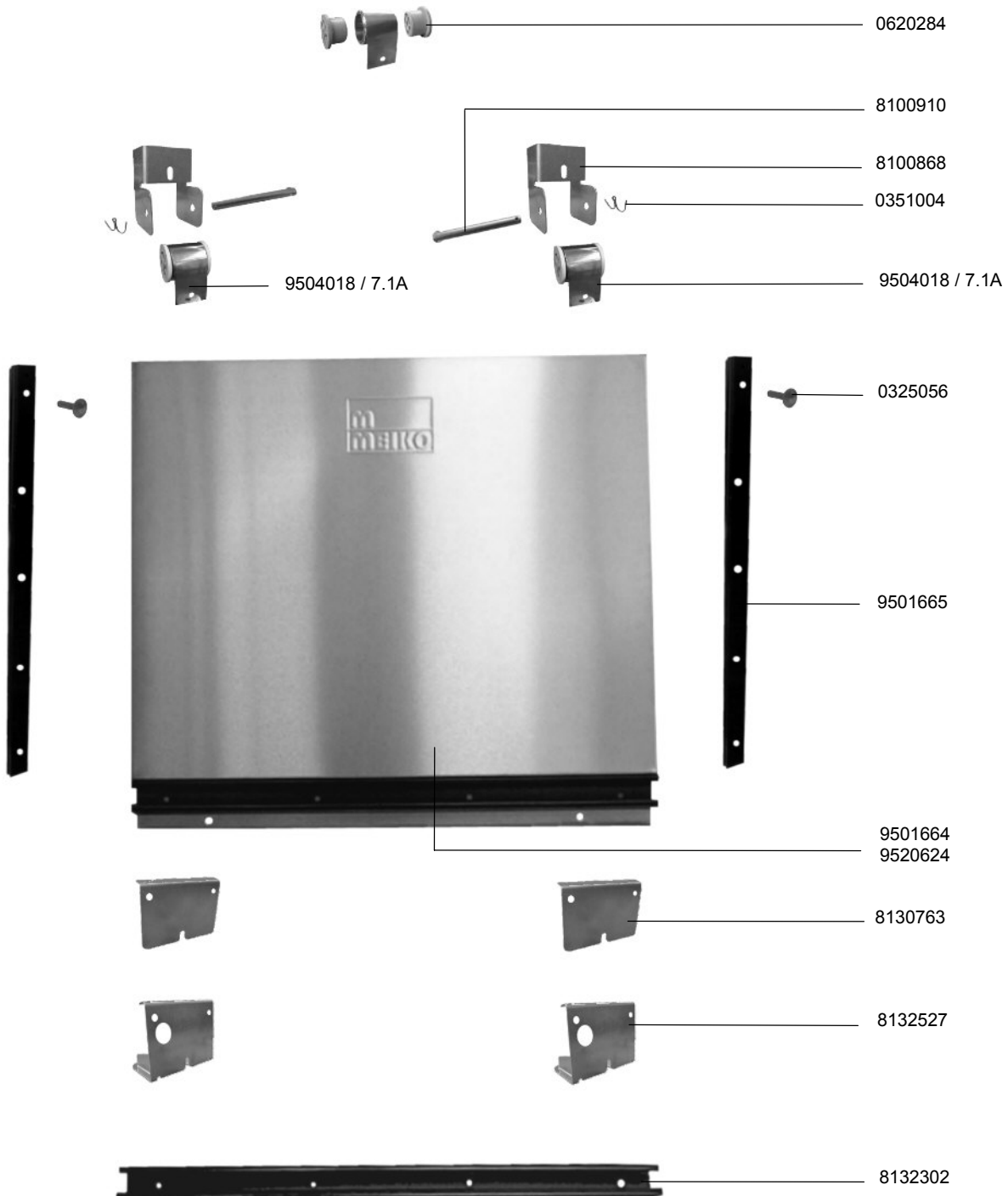

8.2 TÜR 800



8.2 DOOR 800

8.2 PORTE 800

IDENT.-NR. IDENT.-NO.	BEZEICHNUNG	DESIGNATION	DESIGNATION
8132302	TÜRGRIFFFPROFIL TÜR 800MM	DOOR HANDLE PROFILE DOOR 800MM	PROFILE DE POIGNEE DE PORTE, PORTE 800MM
8132527	TÜRANSCHLAG MIT ABLAUFSCHLIESSUNG	DOOR CATCH WITH DRAIN CLOSING SYSTEM	ARRET DE PORTE AVEC SYSTEME DE FERMETURE DE VIDANGE
8130763	TÜRANSCHLAG	DOOR CATCH	ARRET DE PORTE
9501664	TÜR	DOOR	PORTE
9520624	TÜR OHNE PRÄGUNG	DOOR WITHOUT EMBOSING	PORTE SANS ESTAMPE
9501665	FÜHRUNGSSCHIENE	GUIDE RAIL	RAIL DE GUIDAGE
0325056	SCHRAUBE M5X30	SCREW M5X30	VIS M5X30
V 9504018	ROLLFEDER 7.1A	ROLLER SPRING 7.1A	ROULEAU A TROU 7.1A
* 0351004	SPLINT 2X20	SPLIT 2X20	GOUPILLE 2X20
8100868	ROLLFEDERHALTERUNG	SCROLL SPRING SUPPORT	SUPPORT POUR RESSORT A CROSSE
8100910	LAGERBOLZEN KURZ Ø8X78	BOLT SHORT Ø8X78	BOULON Ø8X78
* 0620284	LAGERROLLE ½"	SUPPORT ROLL ½"	ROLEAU DE SUPPORT ½"

8.3 TÜR 1200



8.3 DOOR 1200

8.3 PORTE 1200

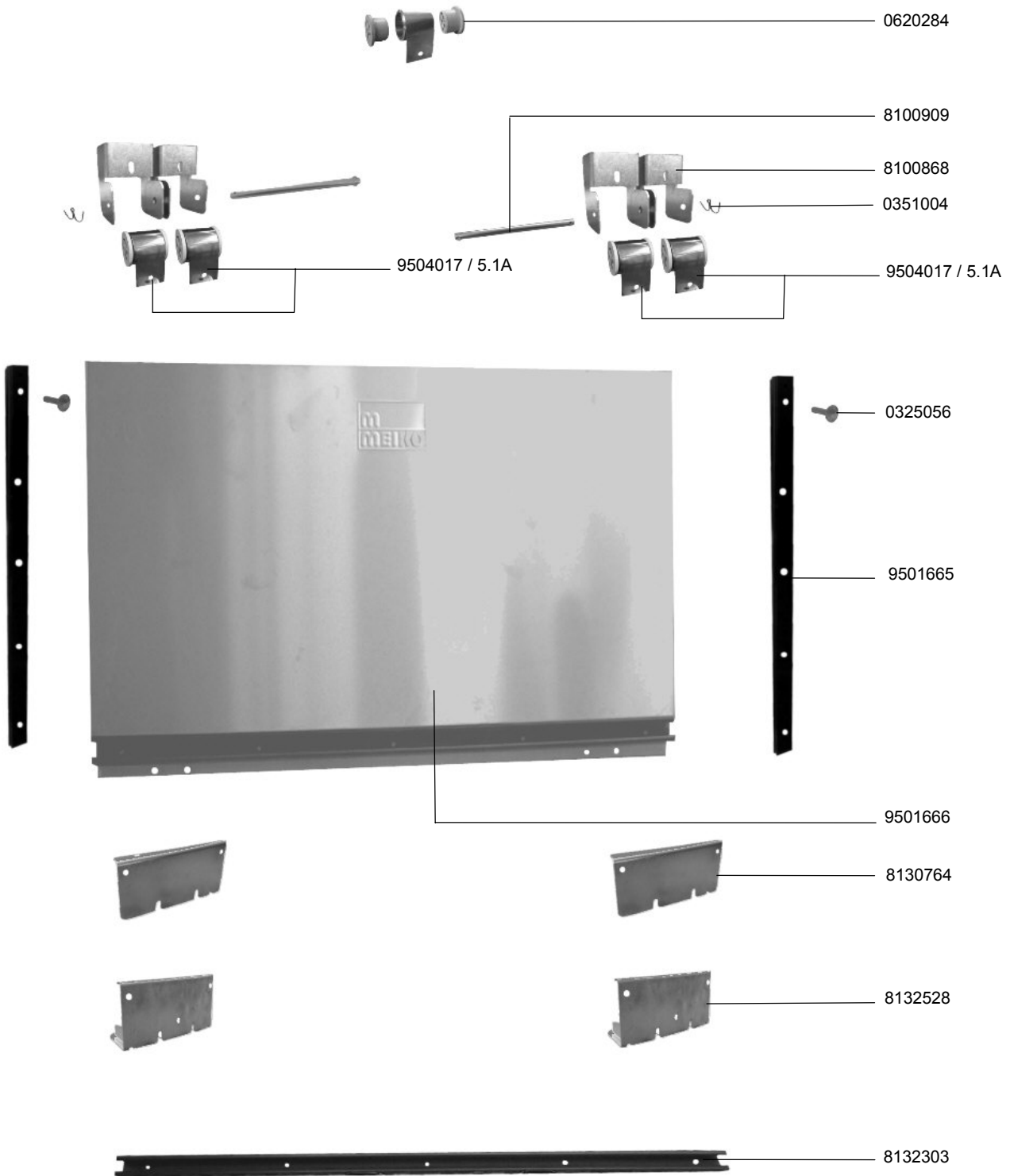

8.3 TÜR 1200



8.3 DOOR 1200

8.3 PORTE 1200

IDENT.-NR. IDENT.-NO.	BEZEICHNUNG	DESIGNATION	DESIGNATION
8132303	TÜRGRIFFFPROFIL TÜR 1200MM	DOOR HANDLE PROFILE DOOR 1200MM	PROFILE DE POIGNEE DE PORTE, PORTE 1200MM
8132528	TÜRANSCHLAG MIT ABLAUFSCHLIESSUNG	DOOR CATCH WITH DRAIN CLOSING SYSTEM	ARRET DE PORTE AVEC SYSTEME DE FERMETURE DE VIDANGE
8130764	TÜRANSCHLAG	DOOR CATCH	ARRET DE PORTE
9501666	TÜR	DOOR	PORTE
9501665	FÜHRUNGSSCHIENE	GUIDE RAIL	RAIL DE GUIDAGE
0325056	SCHRAUBE M5X30	SCREW M5X30	VIS M5X30
V 9504017	ROLLFEDER 5.1A	ROLLER SPRING 5.1A	ROULEAU A TROU 5.1A
* 0351004	SPLINT 2X20	SPLIT 2X20	GOUPILLE 2X20
8100868	ROLLFEDERHALTERUNG	SCROLL SRING SUPPORT	SUPPORT POUR RESSORT A CROSSE
8100909	LAGERBOLZEN LANG Ø8X149	BOLT LONG Ø8X149	BOULON Ø8X149
* 0620284	LAGERROLLE ½"	SUPPORT ROLL ½"	ROLEAU DE SUPPORT ½"

9.0 FRISCHWASSERINSTALLATION (WARMWASSER)



9.0 FRESH WATER INSTALLATION (WARM WATER)

9.0 INSTALLATION A EAU CLAIRE (EAU CHAUDE)

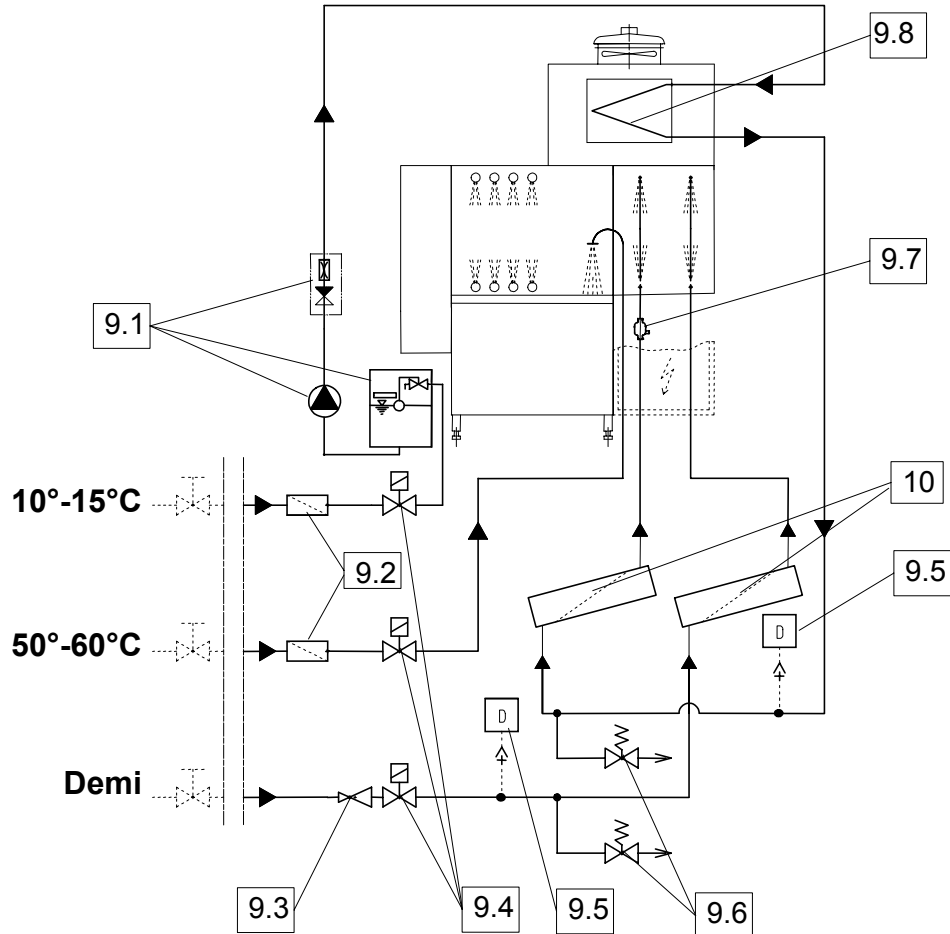

POS.	BEZEICHNUNG	DESIGNATION	DESIGNATION
------	-------------	-------------	-------------

9.1	FRISCHWASSERNETZTRENNUNG	FRESH WATER MAINS ISOLATING DEVICE	DISPOSITIF DE ISOLEMENT DU RESEAU DE EAU
9.2	FILTER	FILTER	FILTRE
9.3	DRUCKMINDERVENTIL	PRESSURE REDUCING VALVE	REDUCTEUR DE PRESSION
9.4	MAGNETVENTIL	SOLENOID VALVE	ELECTROVANNE
9.5	DURCHFLUSSMESSER	FLOW CONTROL	DEBIT METRE
9.6	ÜBERDRUCKVENTIL	OVERPRESSURE VALVE	SOUPAPE DE SURPRESSION
9.7	NETZMITTELMISCHBEHÄLTER	RINSE-AID MIXING CHAMBER	RESERVOIR DE MELANGE DE PRODUIT DE RINCAGE
9.8	WÄRMETAUSCHER	HEAT EXCHANGER	ECHANGEUR DE CHALEUR
10	HEIZUNG	HEATING ELEMENT	RESISTANCE

9.0 FRISCHWASSERINSTALLATION (KALTWASSER)



9.0 FRESH WATER INSTALLATION (COLD WATER)

9.0 INSTALLATION A EAU CLAIRE (EAU FROIDE)

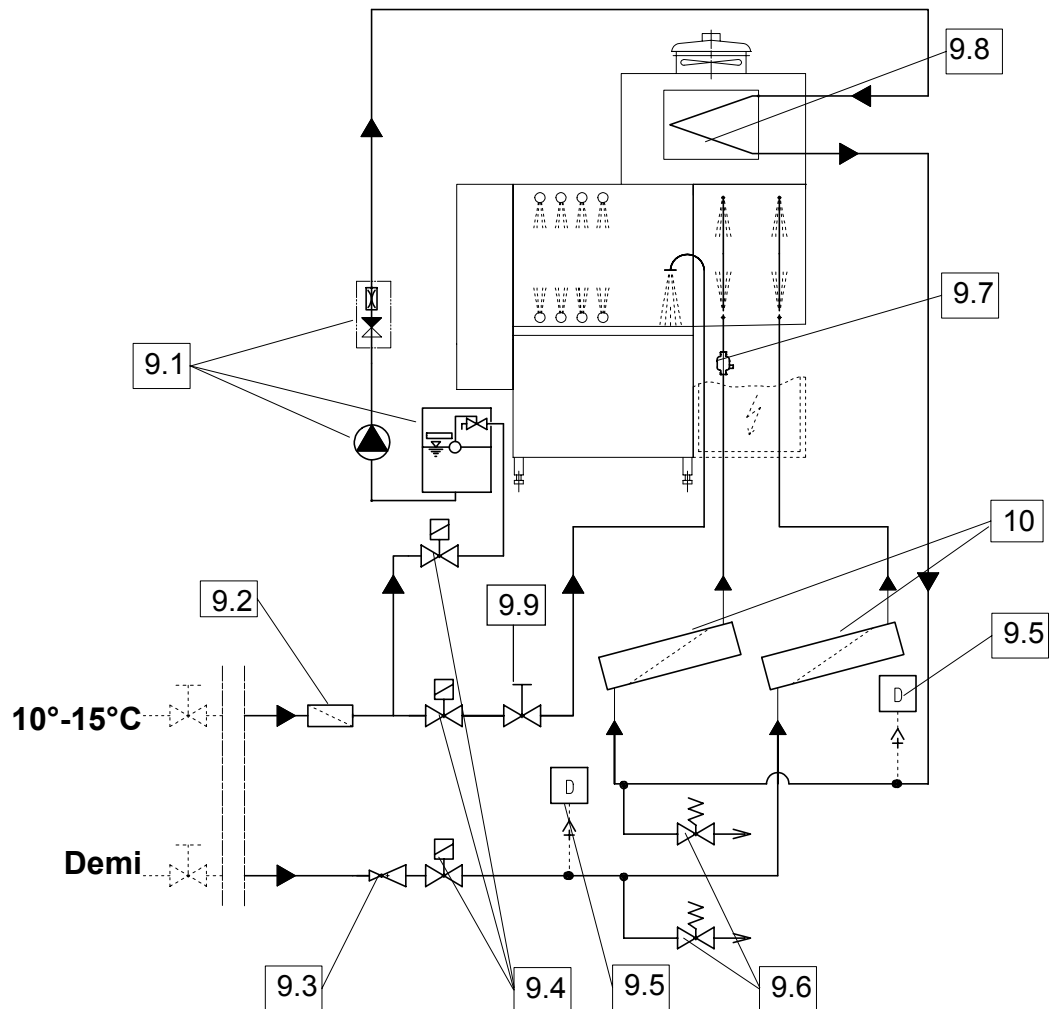

POS.	BEZEICHNUNG	DESIGNATION	DESIGNATION
9.1	FRISCHWASSERNETZTRENNUNG	FRESH WATER MAINS ISOLATING DEVICE	DISPOSITIF DE ISOLEMENT DU RESEAU DE EAU
9.2	FILTER	FILTER	FILTRE
9.3	DRUCKMINDERVENTIL	PRESSURE REDUCING VALVE	REDUCTEUR DE PRESSION
9.4	MAGNETVENTIL	SOLENOID VALVE	ELECTROVANNE
9.5	DURCHFLUSSMESSER	FLOW CONTROL	DEBIT METRE
9.6	ÜBERDRUCKVENTIL	OVERPRESSURE VALVE	SOUPAPE DE SURPRESSION
9.7	NETZMITTELMISCHBEHÄLTER	RINSE-AID MIXING CHAMBER	RESERVOIR DE MELANGE DE PRODUIT DE RINCAGE
9.8	WÄRMETAUSCHER	HEAT EXCHANGER	ECHANGEUR DE CHALEUR
9.9	ABSPERRSCHIEBER	STOP BAFFLE	CLAPET DE ARRET
10	HEIZUNG	HEATING ELEMENT	RESISTANCE

9.0 FRISCHWASSERINSTALLATION (WÄRMEPUMPE)



9.0 FRESH WATER INSTALLATION (HEAT PUMP)

9.0 INSTALLATION A EAU CLAIRE (POMPE DE CHALEUR)

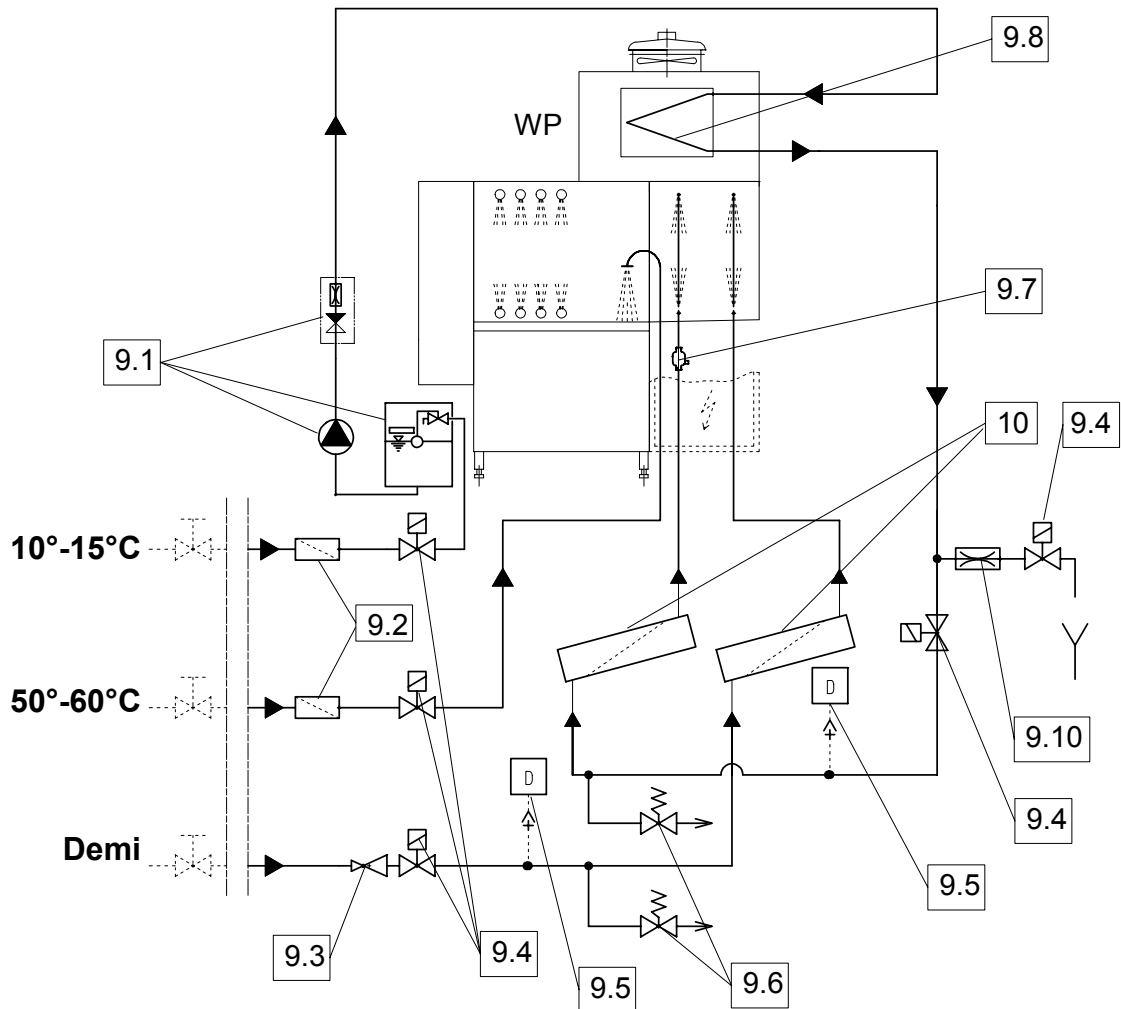

POS.	BEZEICHNUNG	DESIGNATION	DESIGNATION
9.1	FRISCHWASSERNETZTRENNUNG	FRESH WATER MAINS ISOLATING DEVICE	DISPOSITIF DE ISOLEMENT DU RESEAU DE EAU
9.2	FILTER	FILTER	FILTRE
9.3	DRUCKMINDERVENTIL	PRESSURE REDUCING VALVE	REDUCTEUR DE PRESSION
9.4	MAGNETVENTIL	SOLENOID VALVE	ELECTROVANNE
9.5	DURCHFLUSSMESSER	FLOW CONTROL	DEBIT METRE
9.6	ÜBERDRUCKVENTIL	OVERPRESSURE VALVE	SOUPAPE DE SURPRESSION
9.7	NETZMITTELMISCHBEHÄLTER	RINSE-AID MIXING CHAMBER	RESERVOIR DE MELANGE DE PRODUIT DE RINCAGE
9.8	WÄRMETAUSCHER	HEAT EXCHANGER	ECHANGEUR DE CHALEUR
9.10	MENGENREGLER	FLOW REGULATOR	REGULATEUR DE DEBIT
10	HEIZUNG	HEATING ELEMENT	RESISTANCE

9.1 FRISCHWASSERNETZTRENNUNG



9.1 FRESH WATER MAINS ISOLATING DEVICE

9.1 DIPOSITIF DE ISOLEMENT DU RESEAU DE EAU

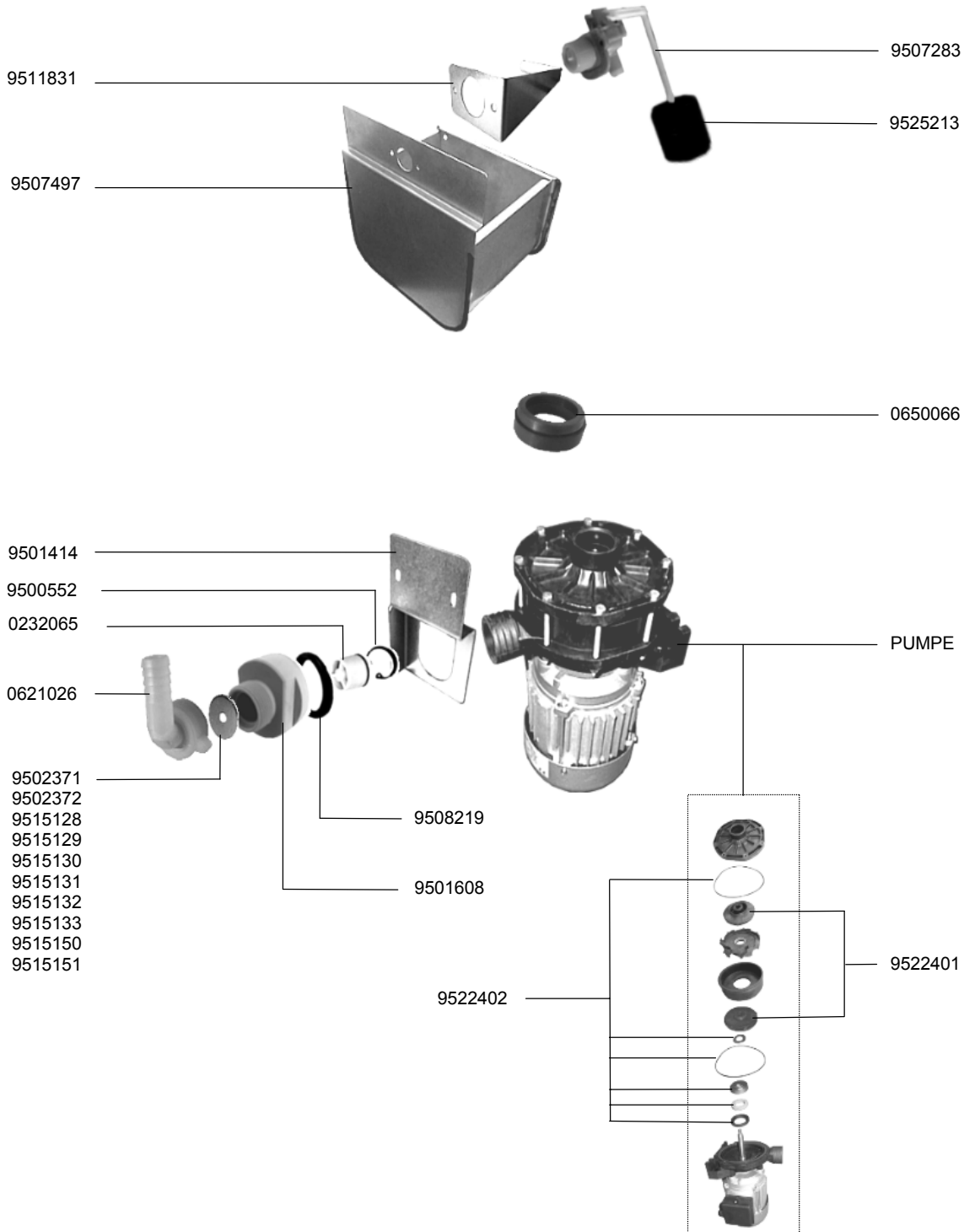

9.1 FRISCHWASSERNETZTRENNUNG



9.1 FRESH WATER MAINS ISOLATING DEVICE

9.1 DIPOSITIF DE ISOLEMENT DU RESEAU DE EAU

IDENT.-NR. IDENT.-NO.	BEZEICHNUNG	DESIGNATION	DESIGNATION
PUMPE	SIEHE ELEKTROSCHALTPLAN	SEE ELECTRIC WIRING DIAGRAM	VOIR SCHEMA ELECTRIQUE
* 0650066	MUFFE	MUFF	MANCHON
* 9525213	SCHWIMMER	FLOAT	FLOTTEUR
* 9507283	SCHWIMMERVERTIL	FLOAT VALVE	VANNE A FLOTTEUR
9511831	HALTEBLECH	SUPPORT	SUPPORT
9507497	BEHÄLTER	CONTAINER	CONTENEUR
9501414	HALTEBÜGEL	SUPPORT	SUPPORT
9500552	SICHERUNGSRING	SAFETY RING	BAGUE DE SECURITE
0232065	RÜCKSCHLAGVENTIL	CHECK VALVE	CLAPET ANTI-RETOUR
0621026	ANSCHLUSSWINKEL	CONNECTION ANGLE	ANGLE DE CONNEXION
9502371	DROSSELSCHEIBE Ø20,5XØ2,4; 270L/H	THROTTLE DISK Ø20,5XØ2,4; 270L/H	DISQUE DE ETRANGLEMENT Ø20,5XØ2,4; 270L/H
9502372	DROSSELSCHEIBE Ø20,5XØ2,5; 280L/H	THROTTLE DISK Ø20,5XØ2,5; 280L/H	DISQUE DE ETRANGLEMENT Ø20,5XØ2,5; 280L/H
9515128	DROSSELSCHEIBE Ø20,5XØ2,6; 290L/H	THROTTLE DISK Ø20,5XØ2,6; 290L/H	DISQUE DE ETRANGLEMENT Ø20,5XØ2,6; 290L/H
9515129	DROSSELSCHEIBE Ø20,5XØ2,7; 300L/H	THROTTLE DISK Ø20,5XØ2,7; 300L/H	DISQUE DE ETRANGLEMENT Ø20,5XØ2,7; 300L/H
9515130	DROSSELSCHEIBE Ø20,5XØ2,8; 320L/H	THROTTLE DISK Ø20,5XØ2,8; 320L/H	DISQUE DE ETRANGLEMENT Ø20,5XØ2,8; 320L/H
9515131	DROSSELSCHEIBE Ø20,5XØ2,9; 330L/H	THROTTLE DISK Ø20,5XØ2,9; 330L/H	DISQUE DE ETRANGLEMENT Ø20,5XØ2,9; 330L/H
9515132	DROSSELSCHEIBE Ø20,5XØ3,0; 330-340L/H	THROTTLE DISK Ø20,5XØ3,0; 330-340L/H	DISQUE DE ETRANGLEMENT Ø20,5XØ3,0; 330-340L/H
9515133	DROSSELSCHEIBE Ø20,5XØ3,1; 350L/H	THROTTLE DISK Ø20,5XØ3,1; 350L/H	DISQUE DE ETRANGLEMENT Ø20,5XØ3,1; 350L/H
9515150	DROSSELSCHEIBE Ø20,5XØ3,2; 360-380L/H	THROTTLE DISK Ø20,5XØ3,2; 360-380L/H	DISQUE DE ETRANGLEMENT Ø20,5XØ3,2; 360-380L/H
9515151	DROSSELSCHEIBE Ø20,5XØ3,3; 400L/H	THROTTLE DISK Ø20,5XØ3,3; 400L/H	DISQUE DE ETRANGLEMENT Ø20,5XØ3,3; 400L/H
9501608	ADAPTER	ADAPTER	ADAPTEUR
* 9508219	O-RING	O-RING	BAGUE
V 9522402	DICHTUNGSSATZ	PACKING	JOINT
* 9522401	PUMPENLAUFRAD	PUMP WHEEL	ROUE DE POMPE

9.2 FILTER

9.2 FILTER

9.2 FILTRE

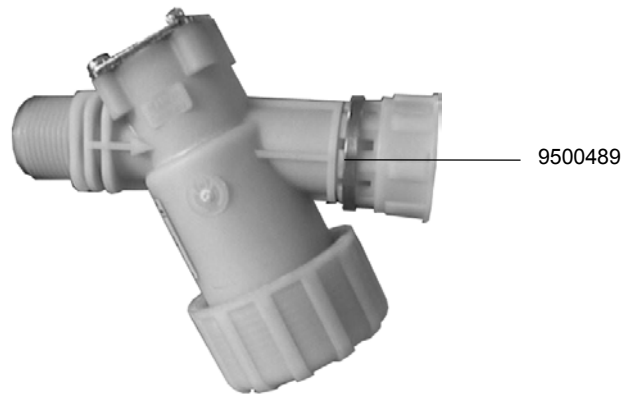
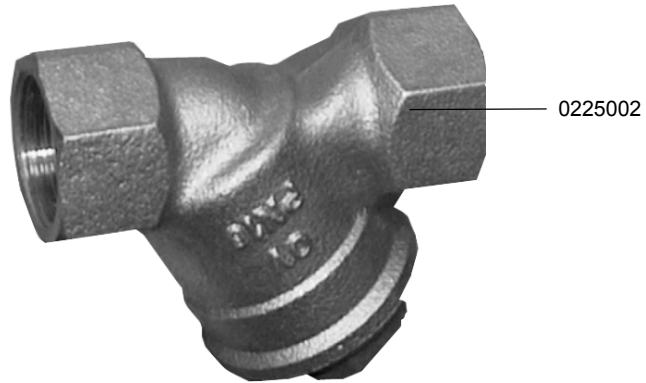

IDENT.-NR. IDENT.-NO.	BEZEICHNUNG	DESIGNATION	DESIGNATION
9500489	SCHMUTZFÄNGER 3/4"	DIRT TRAP 3/4"	COLLECTEUR DE BOUE 3/4"
0225002	SCHMUTZFÄNGER 1/2"	DIRT TRAP 1/2"	COLLECTEUR DE BOUE 1/2"

9.3 DRUCKMINDERVENTIL



9.3 PRESSURE REDUCING VALVE

9.3 REDUCTEUR DE PRESSION

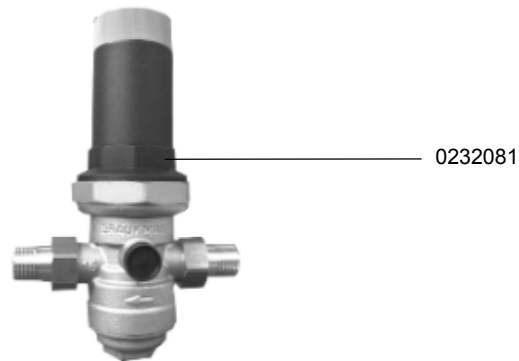
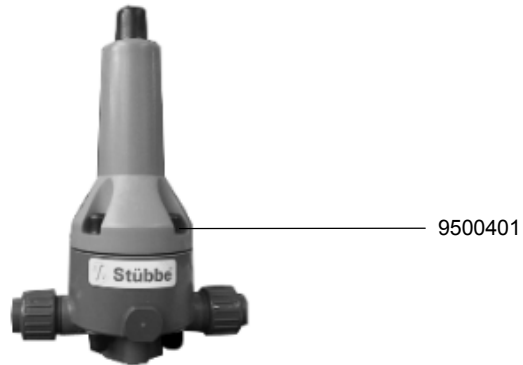
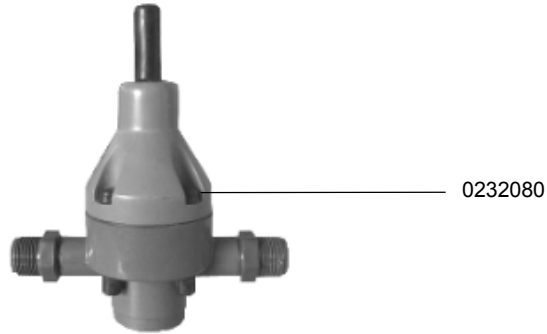

IDENT.-NR. IDENT.-NO.	BEZEICHNUNG	DESIGNATION	DESIGNATION
* 0232081	DRUCKMINDERVENTIL D06FN-1/2" A	PRESSURE REDUCING VALVE D06FN-1/2" A	REDUCTEUR DE PRESSION D06FN-1/2" A
* 9500401	DRUCKMINDERVENTIL DN 10 0,5-9 BAR 3/4"	PRESSURE REDUCING VALVE DN 10 0,5-9 BAR 3/4"	COLLECTEUR DE BOUE DN 10 0,5-9 BAR 3/4"
* 0232080	DRUCKMINDERVENTIL DMV 750 DN 10 1-9 BAR KOMPLETT	PRESSURE REDUCING VALVE DMV 750; DN 10 1-9 BAR	COLLECTEUR DE BOUE DMV 750; DN 10 1-9 BAR

9.4 MAGNETVENTIL



9.4 SOLENOID VALVE

9.4 ELECTROVANNE

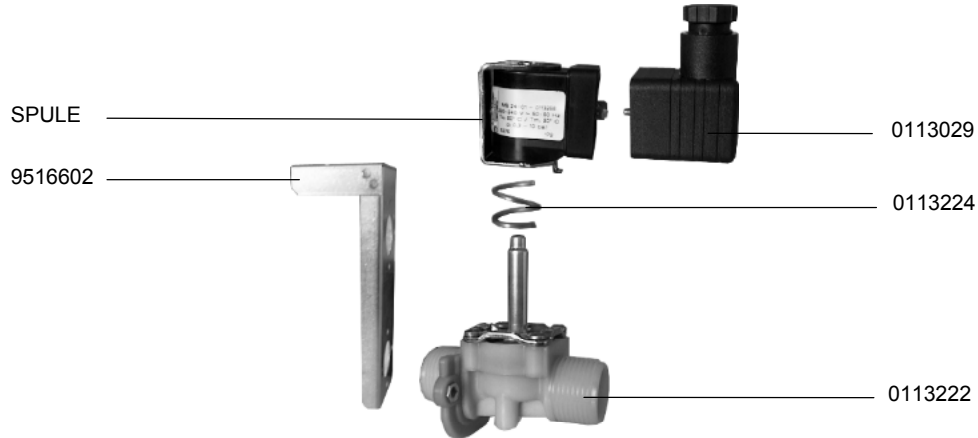

9.4 MAGNETVENTIL



9.4 SOLENOID VALVE

9.4 ELECTROVANNE

IDENT.-NR. IDENT.-NO.	BEZEICHNUNG	DESIGNATION	DESIGNATION
* 9500227	MAGNETVENTIL	SOLENOID VALVE	ELECTROVANNE
* 0113312	MAGNETVENTIL	SOLENOID VALVE	ELECTROVANNE
* 0113222	MAGNETVENTIL	SOLENOID VALVE	ELECTROVANNE
* 0113224	FEDER	SPRING	RESSORT
0113029	STECKBÜCHSE	TIP JACK	FICHE FEMELLE
SPULE	SIEHE ELEKTROSCHALTPLAN	SEE ELECTRIC WIRING DIAGRAMM	VOIR SCHEMA ELECTRIQUE
9516602	HALTERUNG	BRACKET	FIXATION

9.5 DURCHFLUSSMESSER



9.5 FLOW CONTROL

9.5 DEBIT METRE

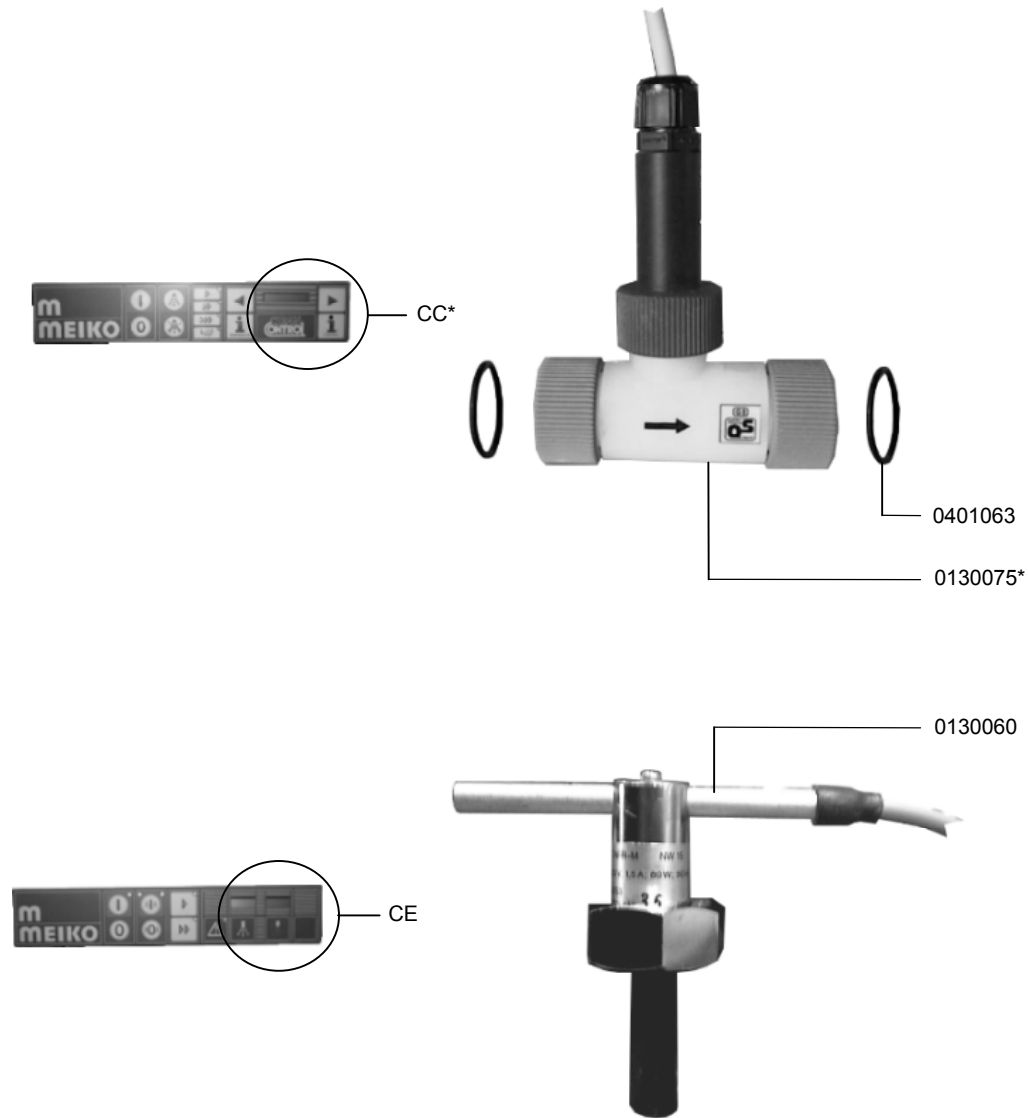

IDENT.-NR. IDENT.-NO.	BEZEICHNUNG	DESIGNATION	DESIGNATION
--------------------------	-------------	-------------	-------------

* 0130060	AUSTAUSCHWÄCHTER KPL.	DRY RUN PROTECTION CPL.	PROTECTEUR DE CHAUFFAGE
* 0130075	DURCHFLUSSMESSER	FLOW CONTROL	DEBIT METRE
* 0401063	O-RING	O-RING	BAGUE

9.6 ÜBERDRUCKVENTIL



9.6 OVERPRESSURE VALVE

9.6 SOUPE DE SURPRESSION

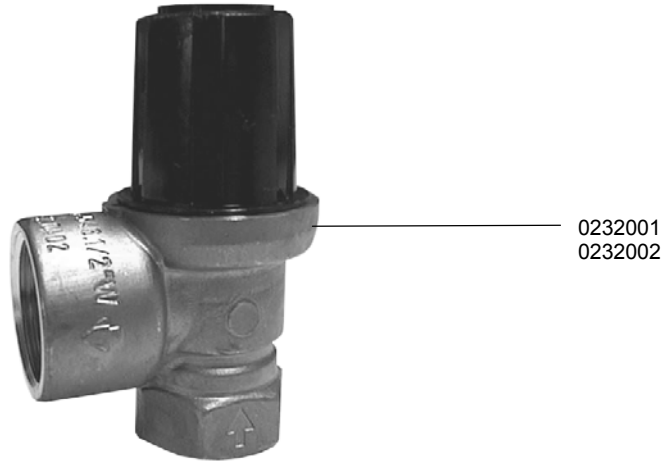

IDENT.-NR. IDENT.-NO.	BEZEICHNUNG	DESIGNATION	DESIGNATION
* 0232001	SICHERHEITSVENTIL 1/2"	OVERPRESSURE VALVE 1/2"	SOUPE DE SURPRESSION 1/2"
* 0232002	SICHERHEITSVENTIL 3/4"	OVERPRESSURE VALVE 3/4"	SOUPE DE SURPRESSION 3/4"

9.7 NETZMITTELMISCHBEHÄLTER



9.7 RINSE-AID MIXING CHAMBER

9.7 RESERVOIR DE MELANGE DE PRODUIT DE RINCAGE

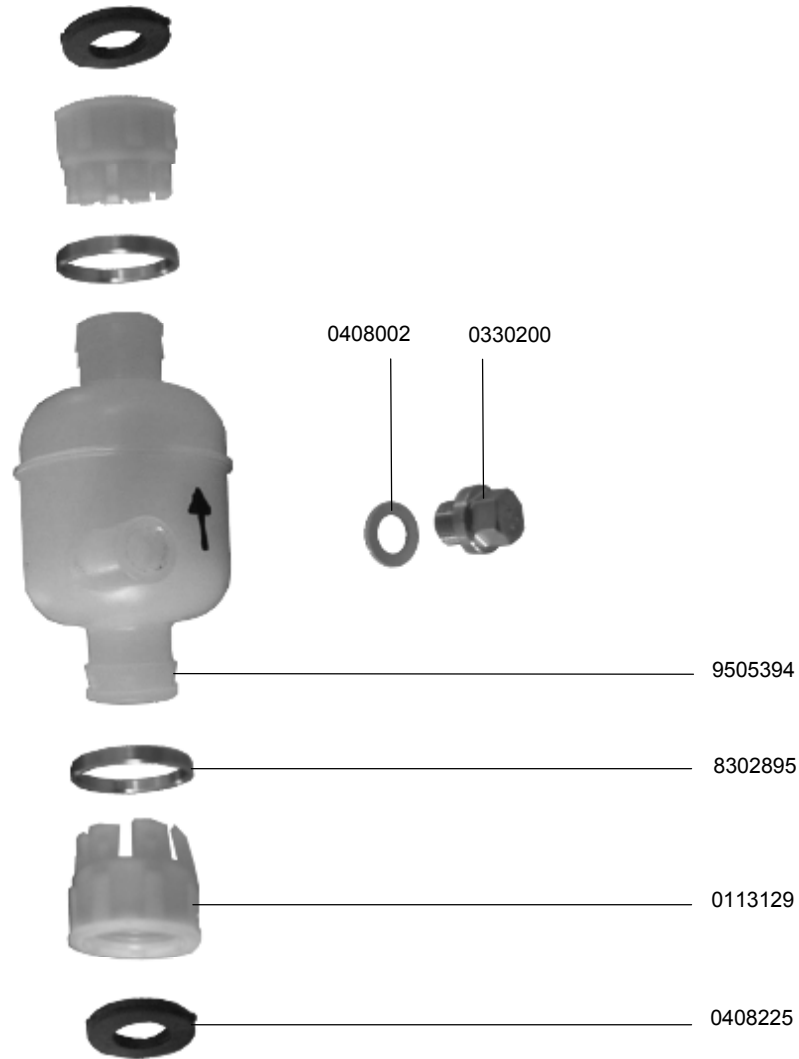

IDENT.-NR. IDENT.-NO.	BEZEICHNUNG	DESIGNATION	DESIGNATION
9513107	MISCHBEHÄLTER KPL.	MIXING CHAMBER CPL.	RESERVOIR DE MELANGE CPL.
0408225	DICHTUNG	PACKING	JOINT
0113129	ANSCHLUSSTÜCK	CONNECTION PART	PIECE DE CONNEXION
8302895	HALTERING	RING	BAGUE
9505394	MISCHBEHÄLTER	MIXING CHAMBER	RESERVOIR DE MELANGE
0330200	VERSCHLUSSRAUBE 1/8"	SCREW 1/8"	VIS 1/8"
0408002	DICHTUNG	PACKING	JOINT

9.8 WÄRMETAUSCHER

9.8 HEAT EXCHANGER

9.8 ECHANGEUR DE CHALEUR

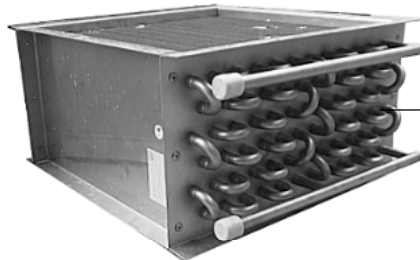

0254026 / 1.4435
9517229 / Cu

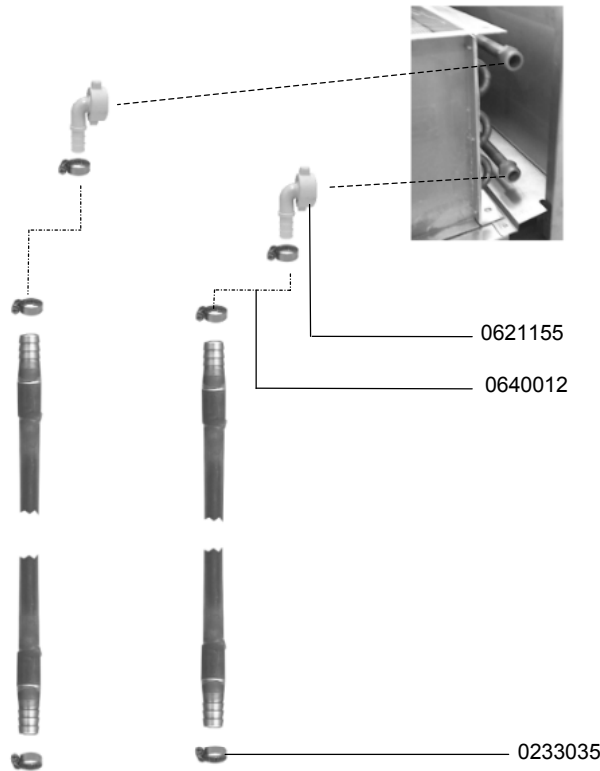

IDENT.-NR. IDENT.-NO.	BEZEICHNUNG	DESIGNATION	DESIGNATION
0233035	SCHLAUCHKLEMME 12-20	HOSE WIRE CLAMP 12-20	COLLIER DE SERRAGE 12-20
0640012	SCHLAUCH	HOSE	TUYAU
0621155	ANSCHLUSSWINKEL	CONNECTION ANGLE	ANGLE DE CONNEXION
0254026	KÜHLER 1.4435	COOLER 1.4435	REFROIDISSEUR 1.4435
9517229	KÜHLER CU	COOLER CU	REFROIDISSEUR CU

9.9 ABSPERRSCHIEBER



9.9 STOP BAFFLE

9.9 CLAPET DE ARRET

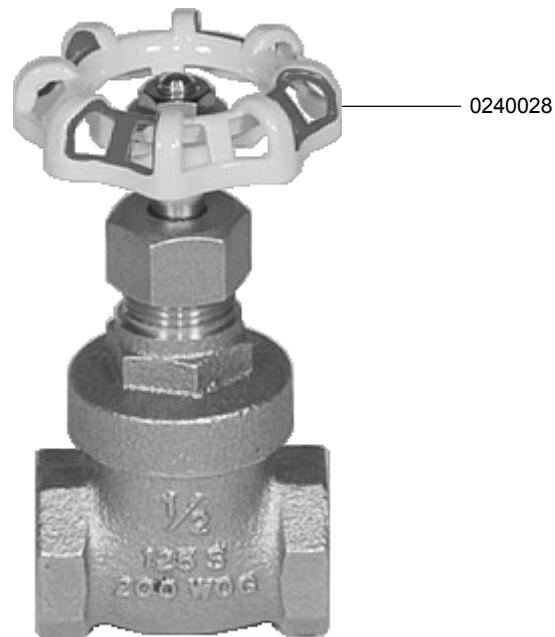

IDENT.-NR. IDENT.-NO.	BEZEICHNUNG	DESIGNATION	DESIGNATION
0240028	ABSPERRSCHIEBER	STOP BAFFLE	CLAPET DE ARRET

9.10 MENGENREGLER

9.10 FLOW REGULATOR

9.10 REGULTEUR DE DEBIT

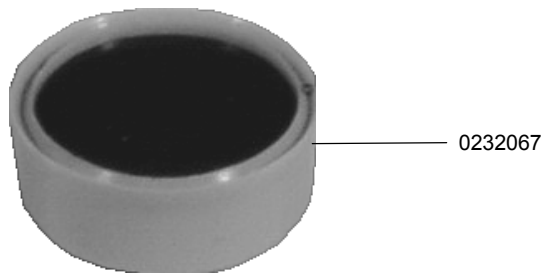

IDENT.-NR. IDENT.-NO.	BEZEICHNUNG	DESIGNATION	DESIGNATION
0232067	MENGENREGLER DURCHFLUSS - 360L/H	FLOW REGULATOR FLOW 360L/H	REGULATEUR DE DEBIT DEBIT 360L/H

10.1 ELEKTROBEHEIZUNG

10.1 ELECTRICAL HEATING

10.1 CHAUFFAGE ELECTRIQUE

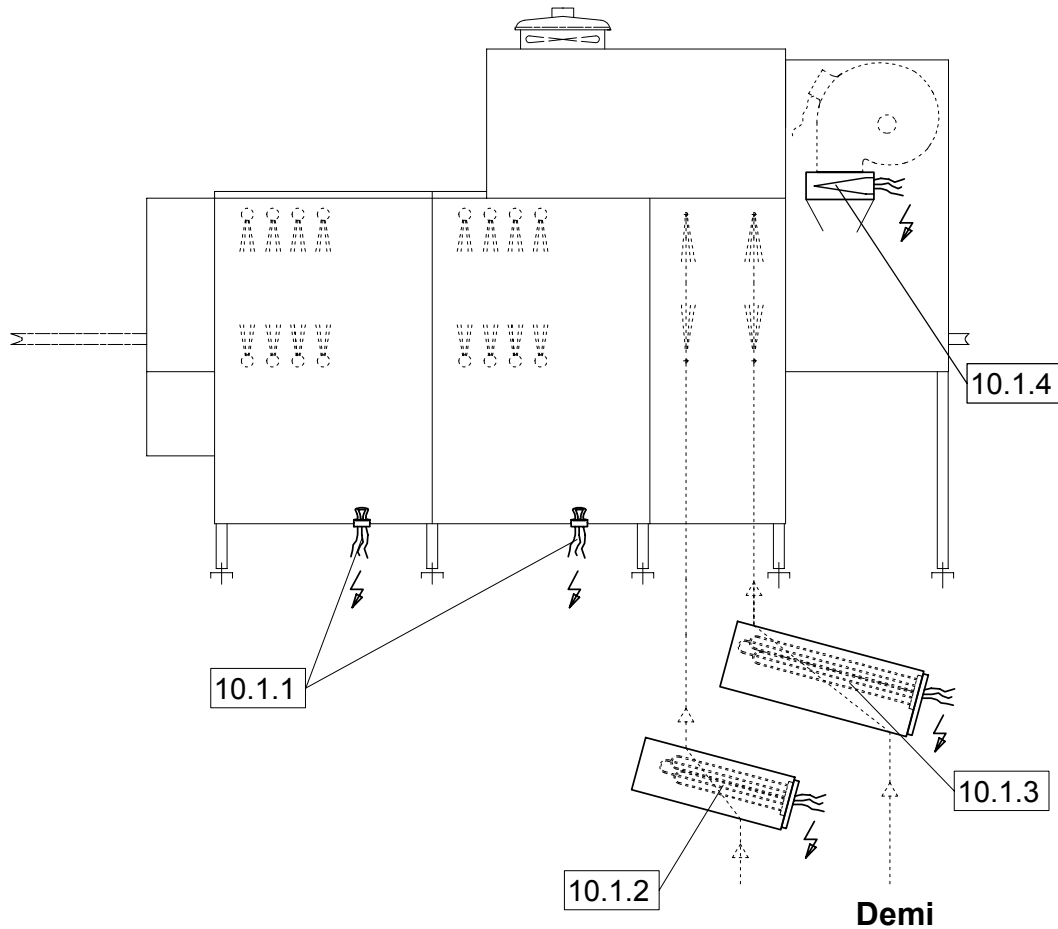

POS.	BEZEICHNUNG	DESIGNATION	DESIGNATION
10.1.1	TANKHEIZUNG ELEKTRISCH	TANK HEATING ELECTRICAL	RESISTANCE DU BAC ELECTRIQUE
10.1.2	BOILER	BOILER	SURCHAUFFEUR
10.1.3	BOILER	BOILER	SURCHAUFFEUR
10.1.4	TROCKNUNGSHEIZREGISTER	HEATING REGISTER	REGISTRE DE CHAUFFAGE

10.1.1 TANKHEIZUNG, ELEKTRISCH



10.1.1 TANK HEATING ELEMENT, ELECTRICAL

10.1.1 RESISTANCE DU BAC, ELECTRIQUE

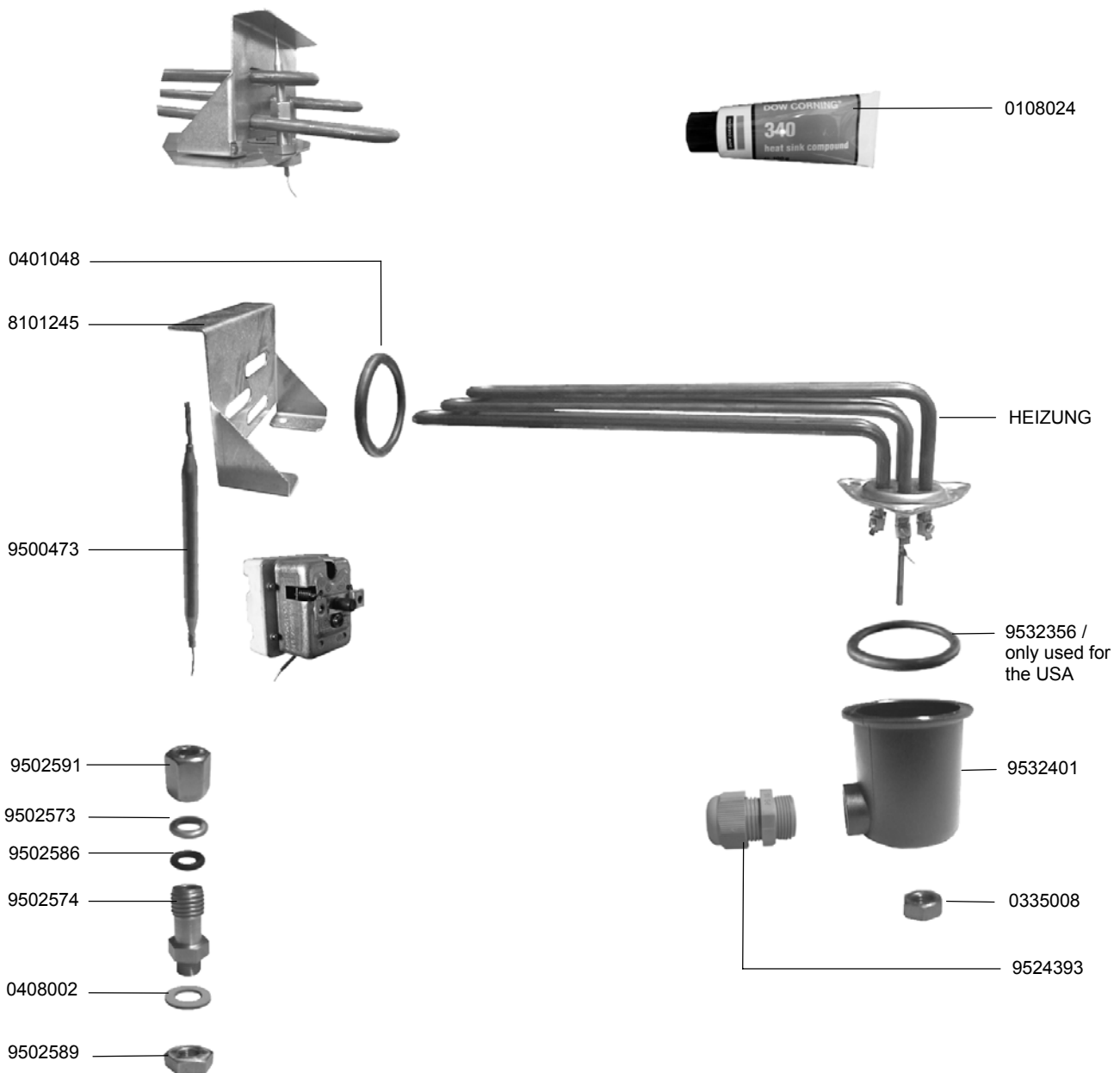

10.1.1 TANKHEIZUNG, ELEKTRISCH



10.1.1 TANK HEATING ELEMENT, ELECTRICAL

10.1.1 RESISTANCE DU BAC, ELECTRIQUE

IDENT.-NR. IDENT.-NO.	BEZEICHNUNG	DESIGNATION	DESIGNATION
0108024	LEITFÄHIGKEITSPASTE	CONDUCTIVE PASTE	PATE DE CONDUCTION
HEIZUNG	SIEHE ELEKTROSCHALTPLAN	SEE ELECTRIC WIRING DIAGRAM	VOIR SCHEMA ELECTRIQUE
* 9532356	O-RING	O-RING	BAGUE
9532401	HEIZSTABABDECKUNG	HEATING ELEMENT COVERED	ELEMENT DE CHAUFFAGE RECOUVERT
0335008	SKT.MUTTER M5	HEXAGON NUT M5	ECROU A 6 PANS M5
9524393	VERSCHRAUBUNG	SCREWING	VISSAGE
9502589	SKT.MUTTER 1/8"	HEXAGON NUT 1/8"	ECROU A 6 PANS 1/8"
0408002	DICHTUNG	PACKING	JOINT
9502574	VERSCHRAUBUNG	SCREWING	VISSAGE
* 9502586	O-RING	O-RING	BAGUE
9502573	SCHEIBE	DISK	DISQUE
9502591	ÜBERWURFMUTTER M12	SLEEVE NUT M12	ECROU RACCORD M12
* 9500473	TEMPERATURFÜHLER	TEMPERATURE PROBE	SONDE DE TEMPERATURE
8101245	BEFESTIGUNG	FIXATION	FIXATION
* 0401048	O-RING	O-RING	BAGUE

10.1.2 DURCHLAUFWASSERERWÄRMER



10.1.2 BOILER

10.1.2 SURCHAFFEUR

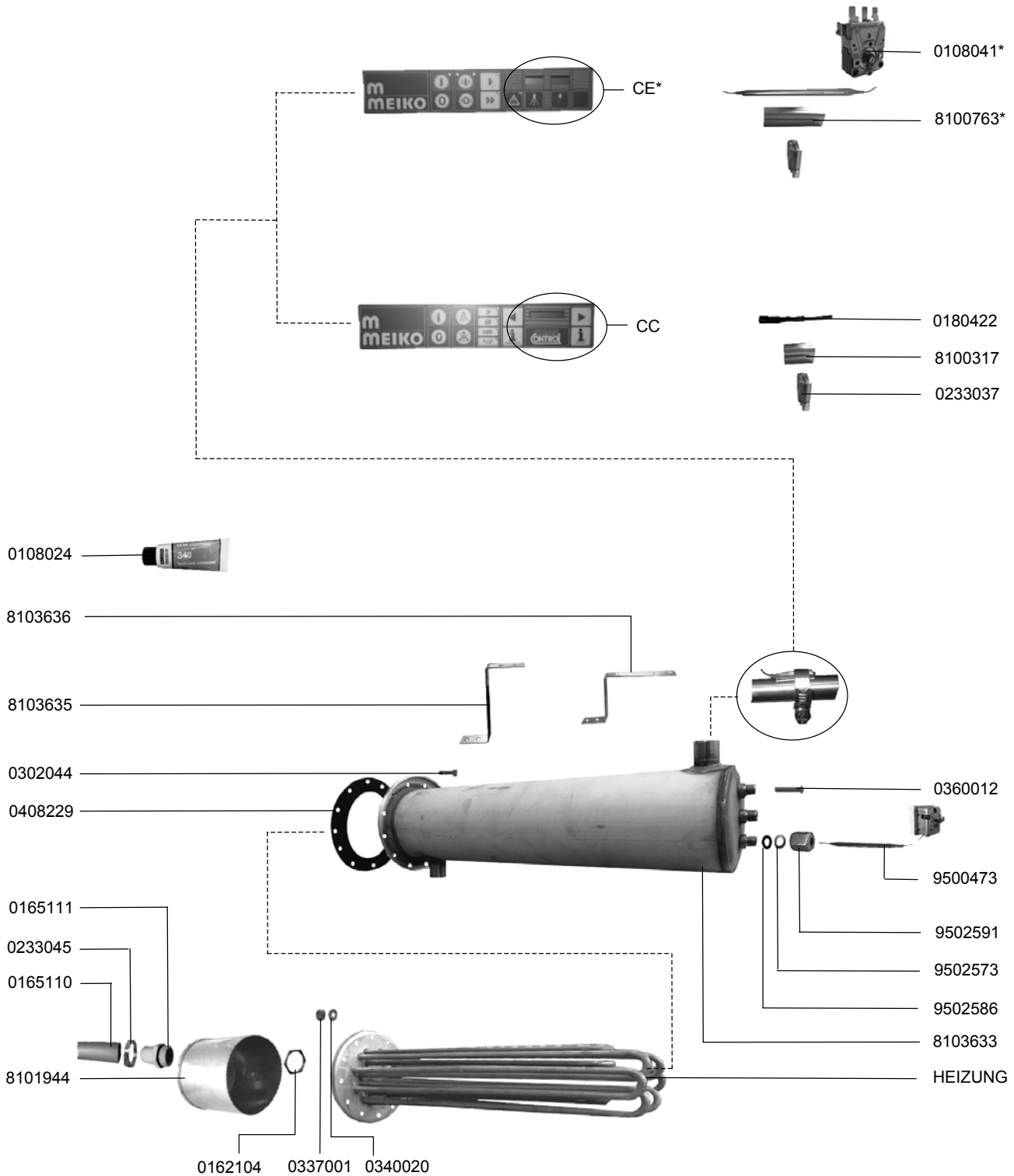

10.1.2 DURCHLAUFWASSERERWÄRMER



10.1.2 BOILER

10.1.2 SURCHAFFEUR

IDENT.-NR. IDENT.-NO.	BEZEICHNUNG	DESIGNATION	DESIGNATION
HEIZUNG	SIEHE ELEKTROSCHALTPLAN	SEE ELECTRIC WIRING DIAGRAMM	VOIR SCHEMA ELECTRIQUE
8103633	BOILER	BOILER	SURCHAUFFEUR
* 9502586	O-RING	O-RING	BAGUE
9502573	SCHEIBE	DISK	DISQUE
* 9500473	TEMPERATURBEGRENZER	TEMPERATURE LIMITER	LIMITEUR DE TEMPERATURE
9502591	ÜBERWURFMUTTER	SLEEVE NUT	ECROU RACCORD
0360012	HALBRUNDNIET	ROUND HEAD RIVET	RIVET A TETE RONDE
0233037	SCHLAUCHKLEMME 16-27	HOSE WIRE CLAMP 16-27	COLLIER DE SERRAGE 16-27
8100317	BEFESTIGUNGSBLECH	FIXATION	FIXATION
0180422	KABELBAUM	CABLE HARNESS	HARNAIS DE CABLES
8100763	BEFESTIGUNG	HOLDER	FIXATION
* 0108041	TEMPERATURBEGRENZER	TEMPERATURE LIMITER	LIMITEUR DE TEMPERATURE
0108024	LEITFÄHIGKEITSPASTE	CONDUCTIVE PASTE	PATE DE CONDUCTION
8103636	BEFESTIGUNGSWINKEL	FIXATION ANGLE	ANGLE DE FIXATION
8103635	BEFESTIGUNGSWINKEL	FIXATION ANGLE	ANGLE DE FIXATION
0302044	SCHRAUBE M6X110	SCREW M6X110	VIS M6X110
0408229	DICHTUNG	PACKING	JOINT
0165111	VERSCHRAUBUNG	SCREWING	VISSAGE
0233045	SCHLAUCHKLEMME 20-32	HOSE WIRE CLAMP 20-32	COLLIER DE SERRAGE 20-32
0165110	SCHLAUCH	HOSE	TUYAU
8101944	SCHUTZABDECKUNG	PROTECTION COVER	RECOUVREMENT DE PROTECTION
0162104	GEGENMUTTER	COUNTERNUT	CONTRE-ECROU
0337001	SKT.MUTTER M5	HEXAGONE NUT M5	ECROU A 6 PANS M5
0340020	SCHEIBE	DISK	DISQUE

10.1.3.1 DURCHLAUFWASSERERWÄRMER



10.1.3.1 BOILER

10.1.3.1 SURCHAFFEUR

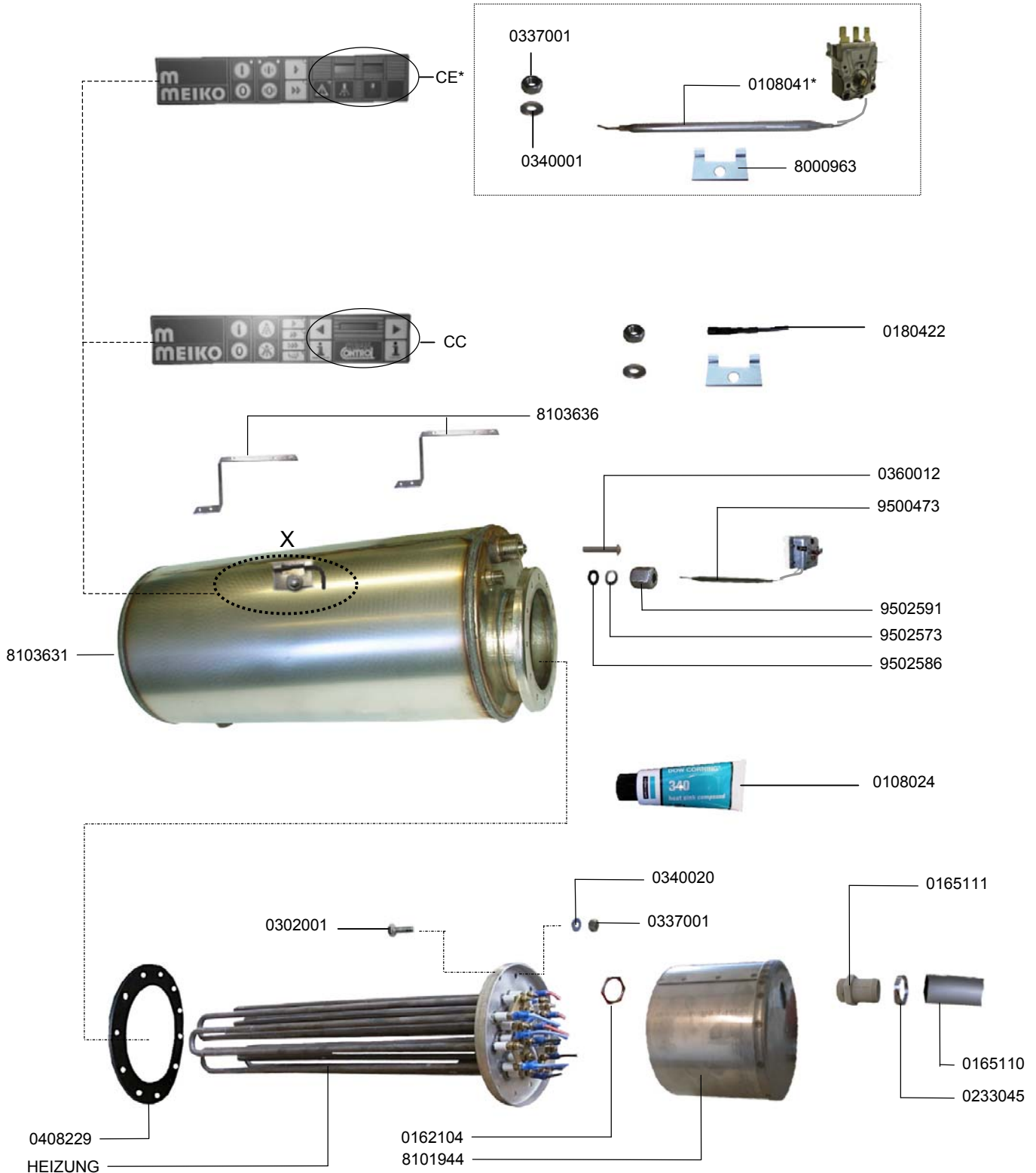

10.1.3.1 DURCHLAUFWASSERERWÄRMER



10.1.3.1 BOILER

10.1.3.1 SURCHAFFEUR

IDENT.-NR. IDENT.-NO.	BEZEICHNUNG	DESIGNATION	DESIGNATION
8101944	SCHUTZABDECKUNG	PROTECTION COVER	RECOUVREMENT DE PROTECTION
0165111	VERSCHRAUBUNG	SCREWING	VISSAGE
0165110	SCHLAUCH	HOSE	TUYAU
0233045	SCHLAUCHKLEMME 20-32	HOSE WIRE CLAMP 20-32	COLLIER DE SERRAGE 20-32
* 9502586	O-RING	O-RING	BAGUE
9502573	SCHEIBE	DISK	DISQUE
9502591	ÜBERWURFMUTTER	SLEEVE NUT	ECROU RACCORD
* 9500473	TEMPERATURBEGRENZER	TEMPERATURE LIMITER	LIMITEUR DE TEMPERATURE
0360012	HALBRUNDNIET	ROUND HEAD RIVET	RIVET A TETE RONDE
8000963	HALTER	FIXATION	FIXATION
0180422	KABELBAUM	CABLE HARNESS	HARNAIS DE CABLES
0340001	SCHEIBE	DISK	DISQUE
0337001	SKT.MUTTER M5	HEXAGONE NUT M5	ECROU A 6 PANS M5
* 0108041	TEMPERATURFÜHLER	TEMPERATURE PROBE	SONDE DE TEMPERATURE
0108024	LEITFÄHIGKEITSPASTE	CONDUCTIVE PASTE	PATE DE CONDUCTION
8103636	BEFESTIGUNGSWINKEL	FIXATION ANGLE	ANGLE DE FIXATION
8103631	BOILER	BOILER	SURCHAUFFEUR
0408229	DICHTUNG	PACKING	JOINT
HEIZUNG	SIEHE ELEKTROSCHALTPLAN	SEE ELECTRIC WIRING DIAGRAM	VOIR SCHEMA ELECTRIQUE
0340020	SCHEIBE	DISK	DISQUE
0337001	SKT.MUTTER M5	HEXAGONE NUT M5	ECROU A 6 PANS M5
0162104	GEGENMUTTER	COUNTERNUT	CONTRE-ECROU

10.1.4 TROCKNUNGSHHEIZREGISTER



10.1.4 DRYING-HEATING REGISTER

10.1.4 REGISTRE DE CHAUFFAGE-SECHAGE

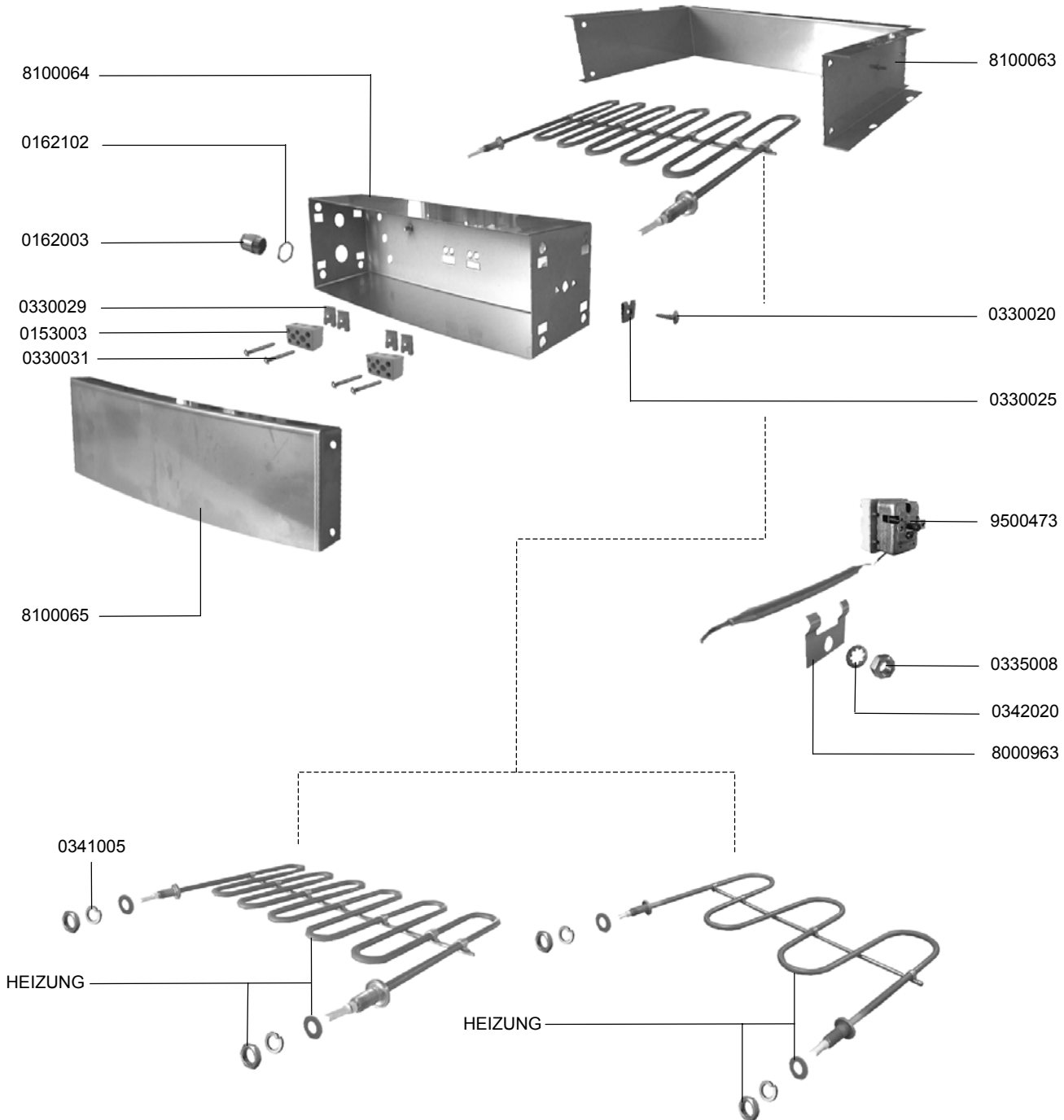

10.1.4 TROCKNUNGSHEIZREGISTER



10.1.4 DRYING-HEATING REGISTER

10.1.4 REGISTRE DE CHAUFFAGE-SECHAGE

IDENT.-NR. IDENT.-NO.	BEZEICHNUNG	DESIGNATION	DESIGNATION
8000963	HALTER	FIXATION	FIXATION
0342020	ZAHNSCHEIBE	TOOTH LOCK WASHER	RONDELLE A FENTE
0335008	MUTTER M5	NUT M5	ECROU M5
* 9500473	TEMPERATURFÜHLER	TEMPERATURE PROBE	SONDE DE TEMPERATURE
0330025	BLECHMUTTER	NUT	ECROU
0330020	SCHRAUBE 4,2X13	SCREW 4,2X13	VIS 4,2X13
8100063	MANTEL	CLADDING	HABILLAGE
8100064	HEIZKÖRPERBLECH	HEATING REGISTER HOUSING	CAISSON DE RESISTANCE
0162102	GEGENMUTTER	COUNTERNUT	CONTRE-ECROU
0162003	VERSCHRAUBUNG	SCREWING	VISSAGE
0330029	KLAMMER	CLAMP	BRIDE DE FIXATION
0153003	ANSCHLUSSKLEMME	CONNECTING TERMINAL	BORNE
0330031	SCHRAUBE 2,9X22	SCREW 2,9X22	VIS 2,9X22
8100065	ABDECKBLECH	COVER	COUVERCLE
0341005	FEDERRING	SPRING RING	BAGUE DE RESSORT
HEIZUNG	SIEHE ELEKTROSCHALTPLAN	SEE ELECTRIC WIRING DIAGRAM	VOIR SCHEMA ELECTRIQUE

11 TAKTSCHALTER



11 INTERVAL SWITCH

11 INTERRUPTEUR DE SYNCHRONISATION

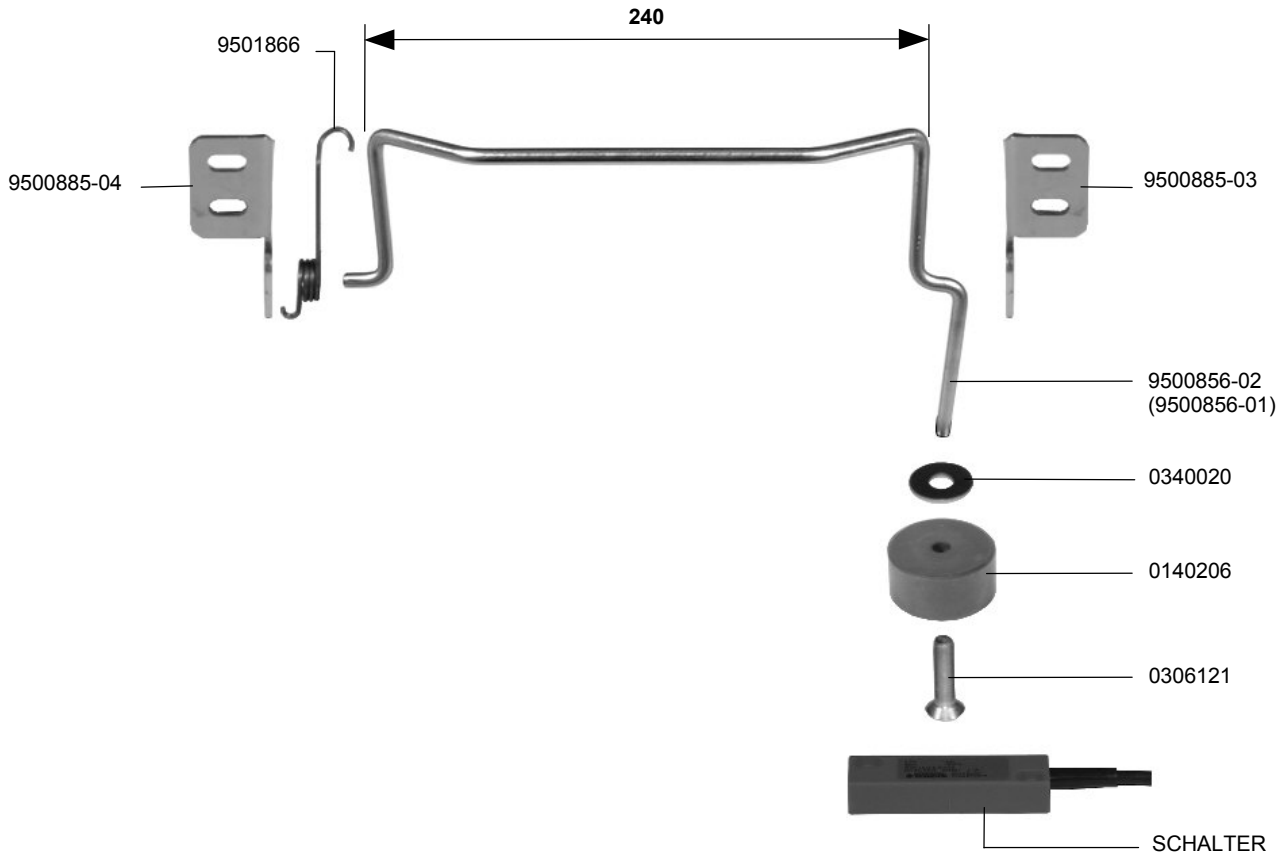

IDENT.-NR. IDENT.-NO.	BEZEICHNUNG	DESIGNATION	DESIGNATION
SCHALTER	SIEHE ELEKTROSCHALTPLAN	SEE ELECTRIC WIRING DIAGRAM	VOIR SCHEMA ELECTRIQUE
0306121	SENKSCHRAUBE M5X20	FLAT HEAD SCREW M5X20	VIS A TETE FRAISEE M5X20
0140206	RINGMAGNET	RING MAGNET	AIMANT ROND
0340020	UNTERLEGSCHLEIFE	SUPPORT DISK	DISQUE
9500856-01	SCHALTSCHLEIFER L-R NICHT ABGEBILDET	SLIDER SWITCH L-R NOT DISPLAYED	INTERRUPTEUR ECONOMISEUR G-D PAS D'IMAGE
9500856-02	SCHALTSCHLEIFER R-L	SLIDER SWITCH R-L	INTERRUPTEUR ECONOMISEUR D-G
9500885-03	LAGERWINKEL	BEARING ANGLE	ANGLE DE LOGEMENT
9500885-04	LAGERWINKEL	BEARING ANGLE	ANGLE DE LOGEMENT
* 9501866	SCHENKELFEDER	TORSION SPRING	RESSORT DE TORSION

12.0 FRISCHWASSERSPARSCHALTER



12.0 FRESH WATER SAVING DEVICE

12.0 INT. ECONOMISEUR - EAU DE RINCAGE

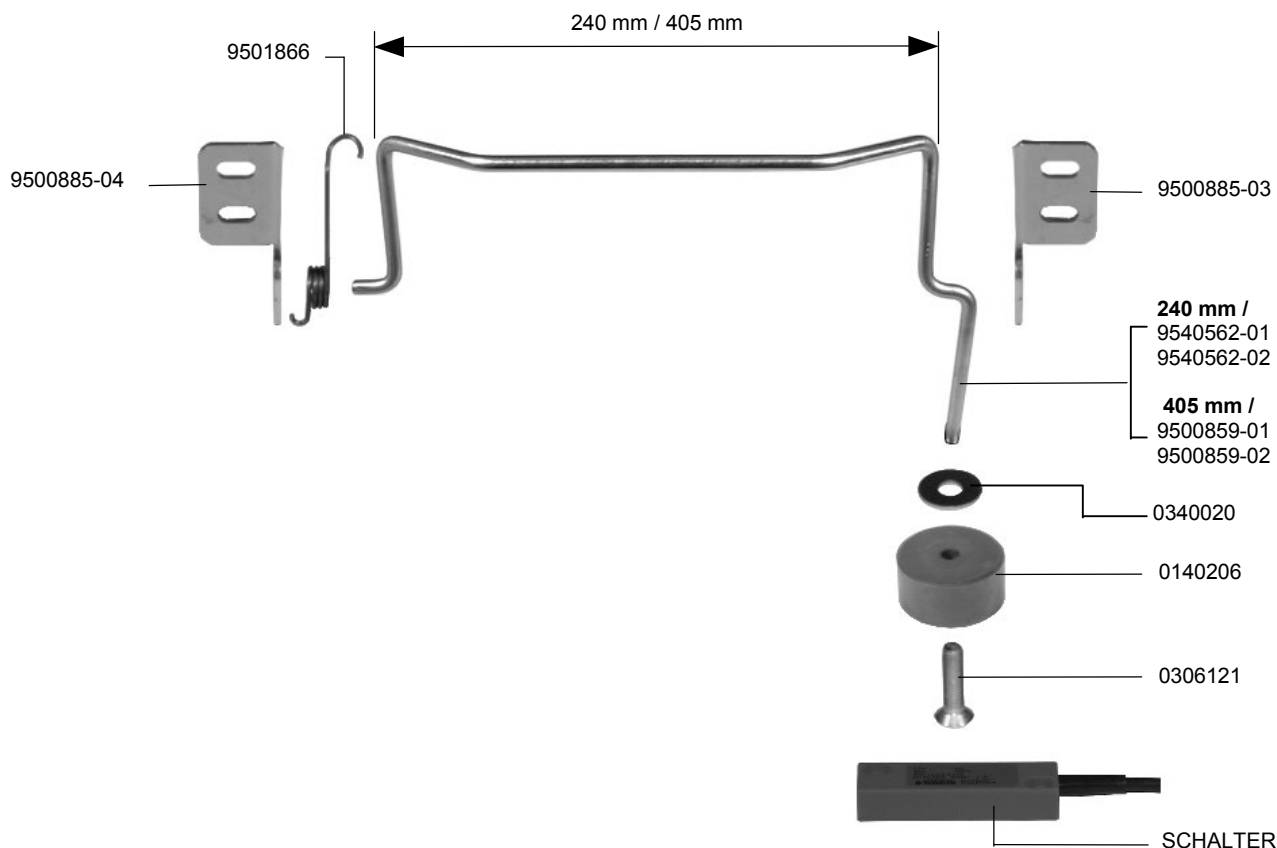

IDENT.-NR. IDENT.-NO.	BEZEICHNUNG	DESIGNATION	DESIGNATION
SCHALTER	SIEHE ELEKTROSCHALTPLAN	SEE ELEKTRIC WIRING DIAGRAM	VOIR SCHEMA ELECTRIQUE
0306121	SENKSCHRAUBE M5X20	FLAT HEAD SCREW M5X20	VIS A TETE FRAISEE M5X20
0140206	RINGMAGNET	RING MAGNET	AIMANT ROND
0340020	UNTERLEGSSCHEIBE	SUPPORT DISK	DISQUE
9540562-01	SCHALTSCHLEIFER L-R	SLIDER SWITCH L-R	INTERRUPTEUR ECONOMISEUR G-D
9540562-02	SCHALTSCHLEIFER R-L NICHT ABGEBILDET	SLIDER SWITCH R-L NOT DISPLAYED	INTERRUPTEUR ECONOMISEUR D-G PAS D' IMAGE
9500859-01	SCHALTSCHLEIFER L-R	SLIDER SWITCH L-R	INTERRUPTEUR ECONOMISEUR G-D
9500859-02	SCHALTSCHLEIFER R-L NICHT ABGEBILDET	SLIDER SWITCH R-L NOT DISPLAYED	INTERRUPTEUR ECONOMISEUR D-G PAS D' IMAGE
9500885-03	LAGERWINKEL	BEARING ANGLE	ANGLE DE LOGEMENT
9500885-04	LAGERWINKEL	BEARING ANGLE	ANGLE DE LOGEMENT
* 9501866	SCHENKELFEDER	TORSION SPRING	RESSORT DE TORSION

15.1.2 MASCHINENSTOLLEN



15.1.2 FEET OF MACHINE

15.1.2 PIEDS DE MACHINE

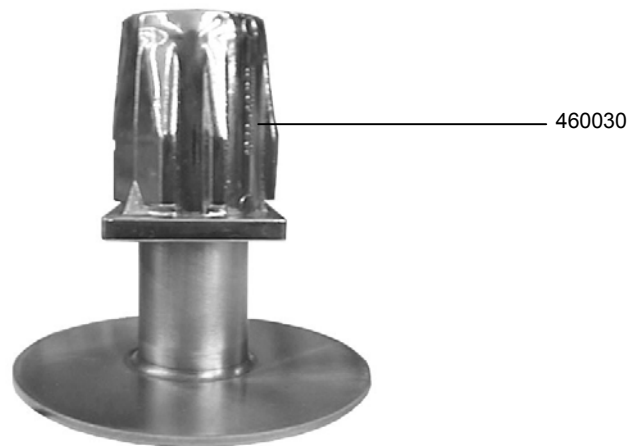
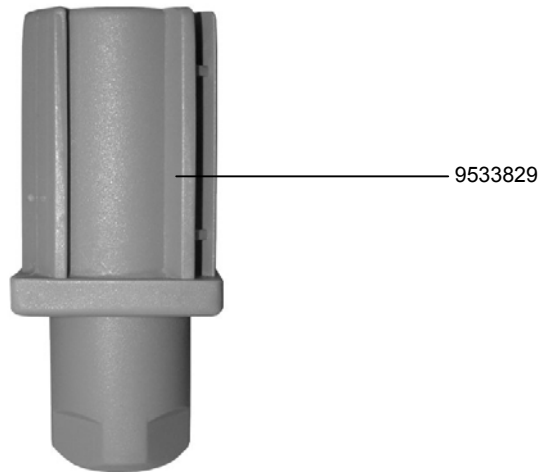

IDENT.-NR. IDENT.-NO.	BEZEICHNUNG	DESIGNATION	DESIGNATION
9533829	TISCHSTOLLEN KPL.	TABLE FEET CPL.	PIEDS DE TABLE CPL.
0460030	STELLFUSS NIRO CAMLOCK 1015-4003-1144	STANDING FEET CAMLOCK 1015-4003-1144	PIEDS NIRO CAMLOCK 1015-4003-1144

15.1.3 ROHRABDICHTUNG

15.1.3 TUBE PACKING

15.1.3 JOINT DE TUYAU

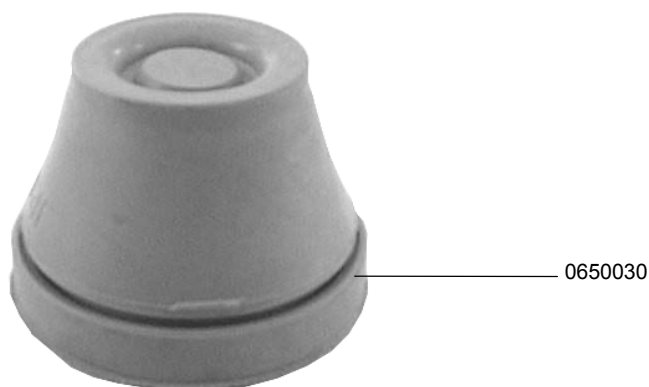

IDENT.-NR. IDENT.-NO.	BEZEICHNUNG	DESIGNATION	DESIGNATION
0650030	KABELDURCHFÜHRUNG	CABLE DUCT	TRAVERSE DE CABLE

15.1.4 SCHWIMMERSCHALTER



15.1.4 FLOATING SWITCH

15.1.4 FLOTTEUR POUR NIVEAU DE BAC

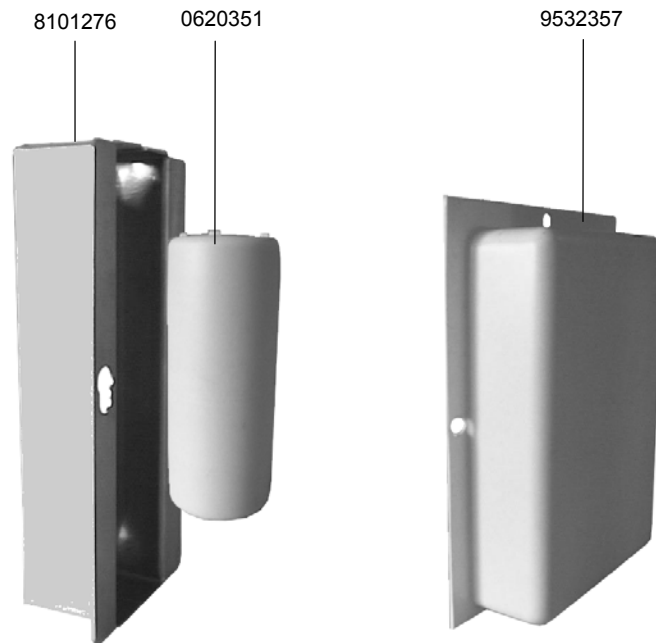

IDENT.-NR. IDENT.-NO.	BEZEICHNUNG	DESIGNATION	DESIGNATION
9532357	ABDECKUNG	COVER	RECOUVREMENT
* 0620351	SCHWIMMER K 343	FLOAT, PLASTIC K 343	FLOTTEUR K 343
8101276	SCHWIMMERFÜHRUNG 177 X 45 X 44	FLOAT GUIDE 177 X 45 X 44	GUIDAGE POUR FLOTTEUR 177 X 45 X 44

15.1.5 TISCHENDSCHALTER

15.1.5 TABLE END SWITCH

15.1.5 INTERRUPTEUR FIN DE COURSE

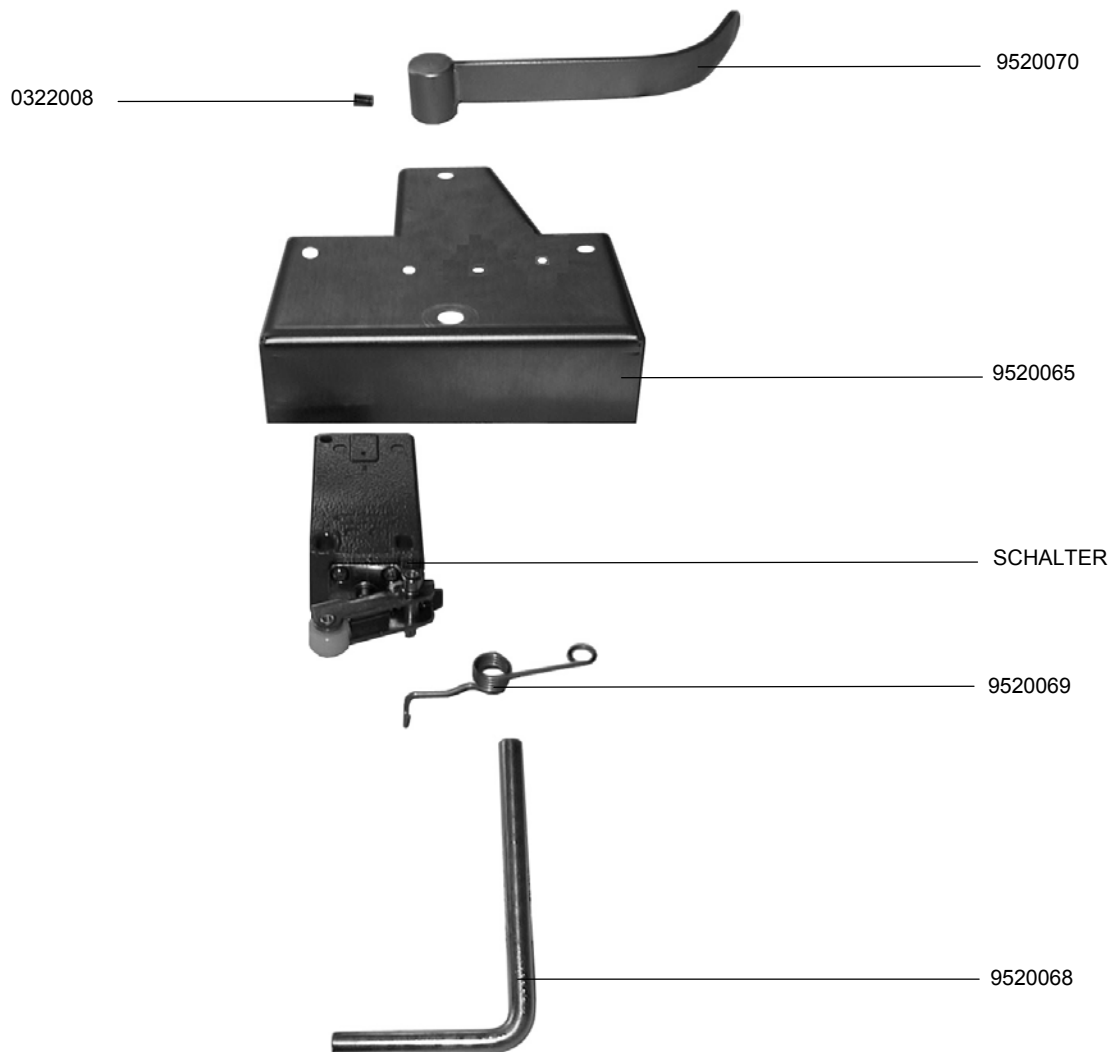

IDENT.-NR. IDENT.-NO.	BEZEICHNUNG	DESIGNATION	DESIGNATION
9520068	SCHALTERFAHNE	ACTUATING LEVER	LEVIER DE MANOEUVRE
* 9520069	SCHENKELFEDER	SPRING	RESSORT
SCHALTER	SIEHE ELEKTROSCHALTPLAN	SEE ELECTRIC WIRING DIAGRAM	VOIR SCHEMA ELECTRIQUE
9520065	BEFESTIGUNGSPLATTE	BASE PLATE	PLAQUE DE MONTAGE
9520070	SCHALTERFAHNE	ACTUATING LEVER	LEVIER DE MANOEUVRE
0322008	GEWINDESTIFT M6X8	SET SCREW M6X8	VIS SANS TETE M6X8

15.2.1.1 TANKABLAUF



15.2.1.1 DRAIN

15.2.1.1 VIDANGE

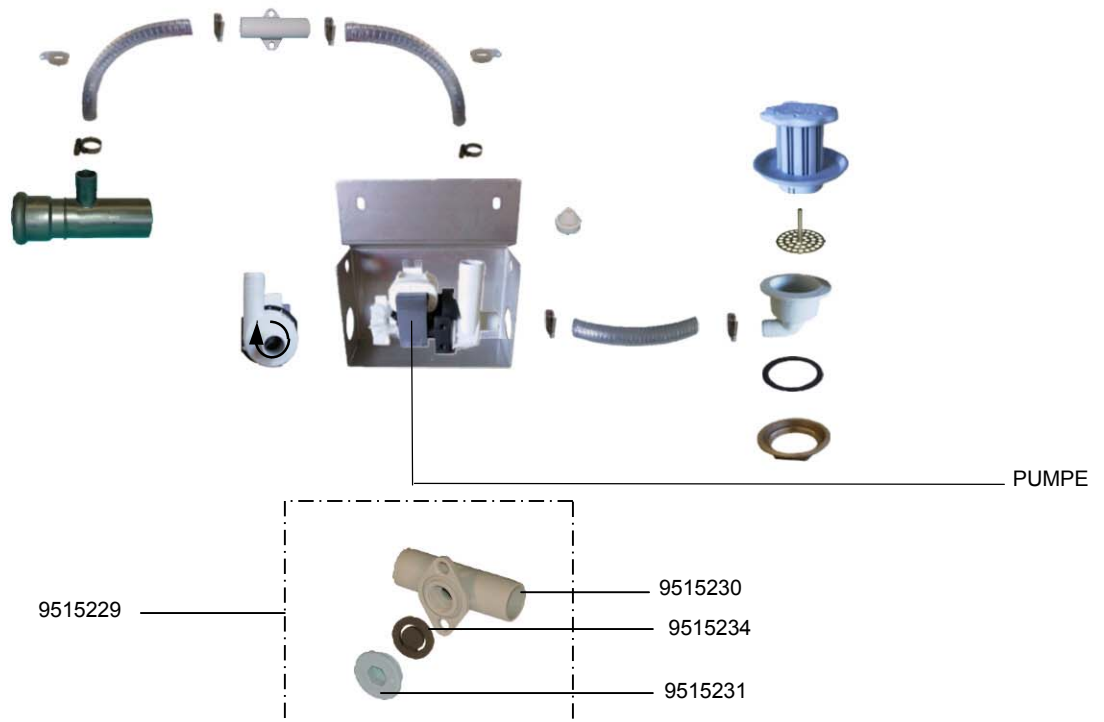
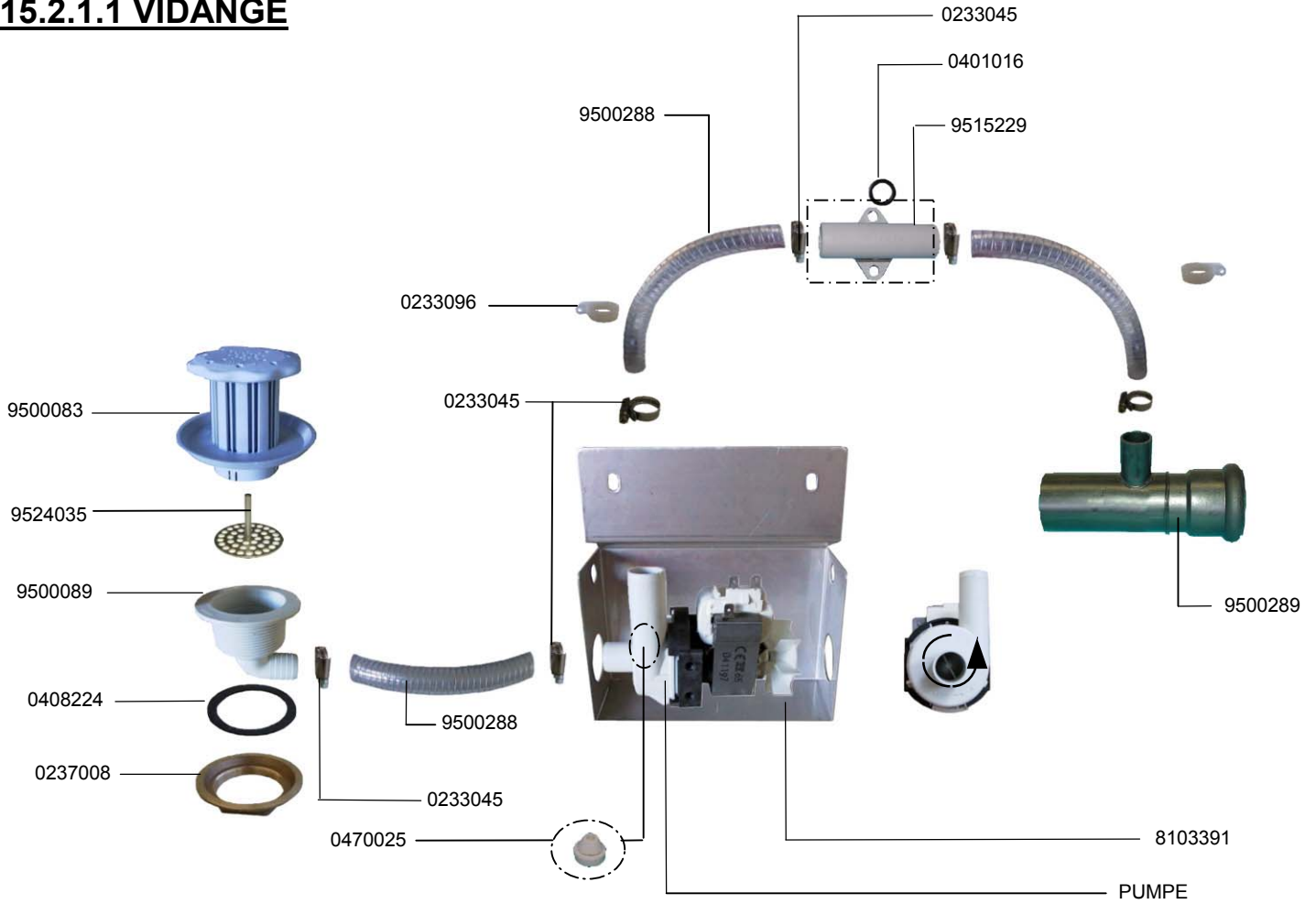

15.2.1.1 TANKABLAUF



15.2.1.1 DRAIN

15.2.1.1 VIDANGE

IDENT.-NR. IDENT.-NO.	BEZEICHNUNG	DESIGNATION	DESIGNATION
0233045	SCHLAUCHKLEMME 20-32	HOSE WIRE CLAMP 20-32	COLLIER DE SERRAGE 20-32
0401016	DICHTUNG	PACKING	JOINT
9500289	ROHR	TUBE	TUYAU
8103391	PUMPENHALTERUNG	PUMP SUPPORT	SUPPORT DE POMPE
PUMPE	SIEHE ELEKTROSCHALTPLAN	SEE ELECTRIC WIRING DIAGRAM	VOIR SCHEMA ELECTRIQUE
9500288	SCHLAUCH	HOSE	TUYAU
0237008	MUTTER 2"	NUT 2"	ECROU 2"
0408224	DICHTUNG	PACKING	JOINT
9500089	ABLAUFVENTIL	DRAIN VALVE	VANNE DE VIDANGE
9524035	SIEB FÜR ABLAUF	SIEVE FOR DRAIN	TAMIS POUR VIDANGE
9500083	STANDSIEB	SIEVE	FILTRE
0233096	SCHLAUCHKLEMME	HOSE WIRE CLAMP	COLLIER DE SERRAGE
9515229	ENTLÜFTUNGSVENTIL KPL	VENT VALVE CPL	VANNE D' AERATION CPL
9515230	ENTLÜFTUNGSVENTIL	VENT VALVE	VANNE D' AERATION
* 9515234	DICHTUNG	PACKING	JOINT
9515231	VERSCHLUSSSCHRAUBE	SCREW PLUG	BOUCHON FILETE DE DECHARGE
0470025	GUMMIPUFFER	RUBBER BUFFER	TAMPON EN CAOUTCHOUC

15.2.2 ABSAUGGEBLÄSE



15.2.2 EXTRACTION FAN

15.2.2 VENTILATEUR D'ASPIRATION



IDENT.-NR. IDENT.-NO.	BEZEICHNUNG	DESIGNATION	DESIGNATION
MOTOR	SIEHE ELEKTROSCHALTPLAN	SEE ELECTRIC WIRING DIAGRAM	VOIR SCHEMA ELECTRIQUE

15.2.3 ABSAUGGEBLÄSE Ø 400

15.2.3 EXTRACTION FAN Ø 400

15.2.3 VENTILATEUR D'ASPIRATION Ø 400



IDENT.-NR. IDENT.-NO.	BEZEICHNUNG	DESIGNATION	DESIGNATION
MOTOR	SIEHE ELEKTROSCHALTPLAN	SEE ELECTRIC WIRING DIAGRAM	VOIR SCHEMA ELECTRIQUE

15.2.4 RADIALGEBLÄSE (MRL-0,75KW)



15.2.4 RADIAL FAN

15.2.4 VENTILATEUR RADIAL

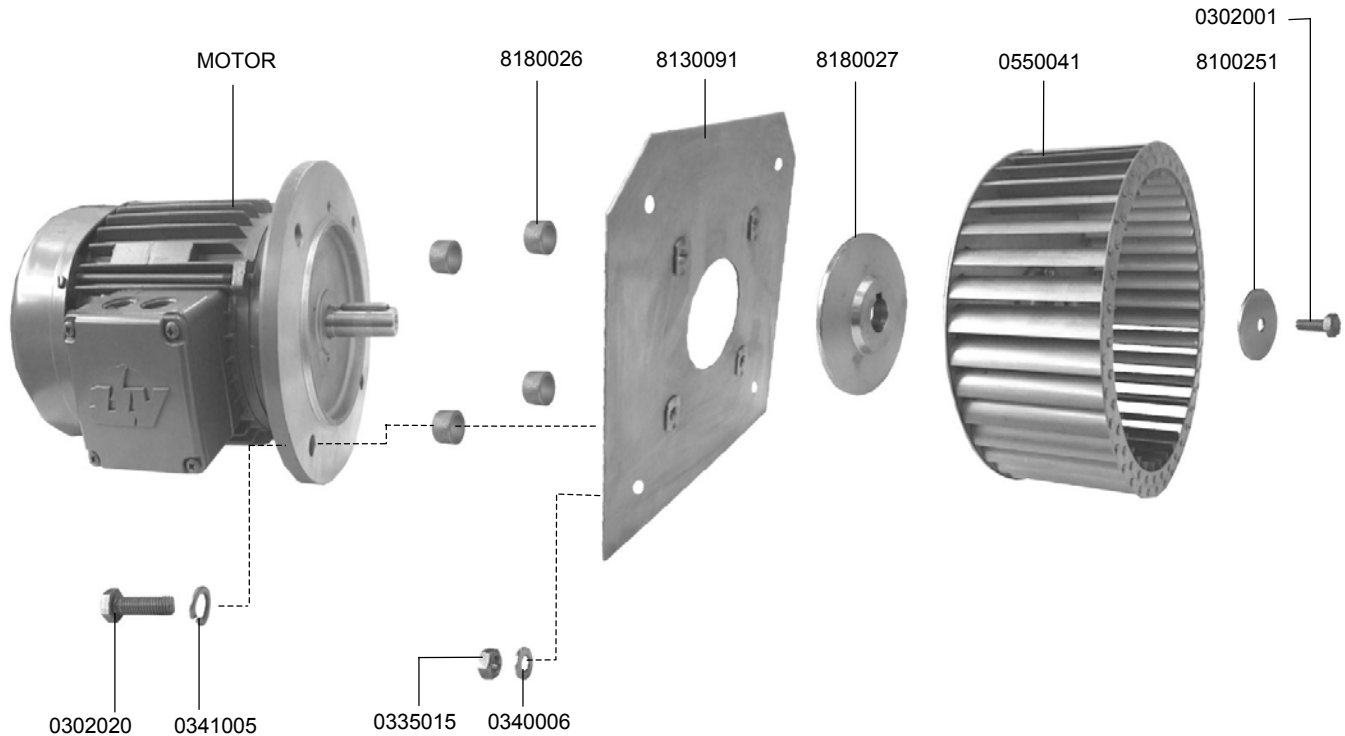

IDENT.-NR. IDENT.-NO.	BEZEICHNUNG	DESIGNATION	DESIGNATION
0302001	SKT.-SCHRAUBE M6X15	HEXAGON SCREW M6X15	VIS A 6 PANS M6X15
8100251	U-SCHEIBE Ø34X7X2, 1.4301	FRONT DISC Ø34X7X2; 1.4301	RONDELLE Ø34X7X2, 1.4301
0550041	LÜFTERRAD 12504271022-E Ø225X100, 1.4301	VENTILATOR WHEEL WITH CENTER Ø225X100, 1.4301	ROUE DE VENTILATEUR AVEC MOYEU Ø225X100, 1.4301
8180027	SCHLEUDERSCHEIBE Ø90X19X11,5, CUZN	CENTRIFUGAL DISC Ø90X19X11,5, CUZN	RONDELLE CENTRIFUGE Ø90X19X11,5, CUZN
8130091	MOTORPLATTE FÜR MRL 280X280X2, 1.4301	MOTOR SUPPORT F. MRL-FAN 280X280X2, 1.4301	PLAQUE SUPPORT DE MOTEUR 280X280X2, 1.4301
8180026	DISTANZ LÜFTERMOTOR Ø17X10, 1.4301	DISTANCE PIECE F. EXTRACTION MOTOR Ø17X10, 1.4301	PIECE DE DISTANCE POUR VENTILATEUR Ø17X10, 1.4301
MOTOR	SIEHE ELEKTROSCHALTPLAN	SEE ELECTRIC WIRING DIAGRAM	VOIR SCHEMA ELECTRIQUE
0302020	SKT.-SCHRAUBE M10X25	HEXAGON SCREW M10X25	VIS A 6 PANS M10X25
0341005	FEDERRING A10	FEATHER KEY A10	RONDELLE RESSORT A10
0335015	SKT.-MUTTER M8	HEXAGON NUT M8	ECROU A 6 PANS M8
0340006	U-SCHEIBE MS. VERN. 8,4X18X2	WASHER BRASS NICKELLED 8,4X18X2	RONDELLE EN LAITON NICKELE 8,4X18X2

15.2.5 FROSTSCHUTZWÄCHTER

15.2.5 ANTI-FREEZE PROTECTION

15.2.5 PROTECTEUR ANTI-GEL

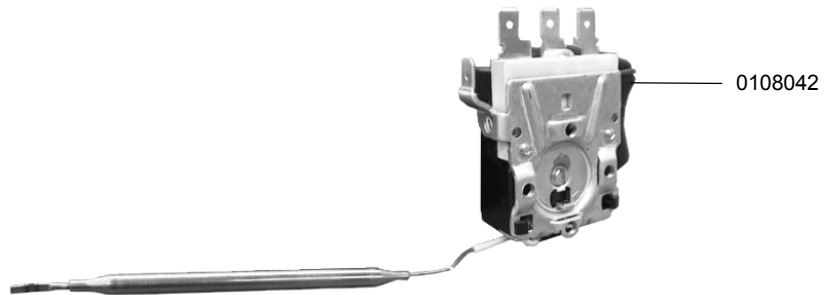
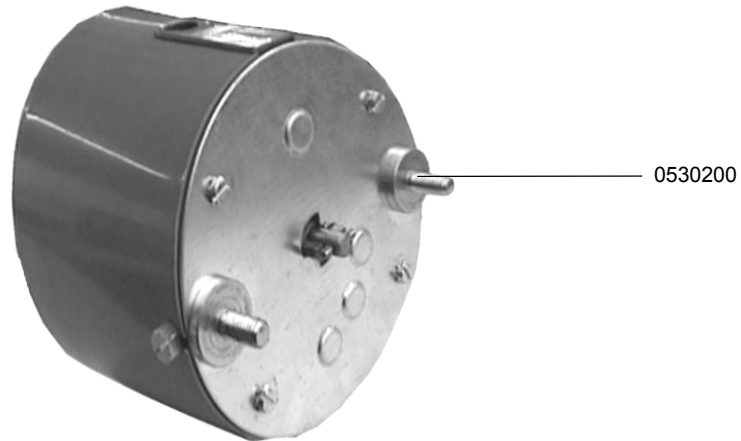

IDENT.-NR. IDENT.-NO.	BEZEICHNUNG	DESIGNATION	DESIGNATION
* 0108042	TEMPERATURFÜHLER	TEMPERATURE PROBE	SONDE DE TEMPERATURE
0530200	MOTOR	MOTOR	MOTEUR

15.2.6 SCHWIMMERSCHALTER



15.2.6 FLOATING SWITCH

15.2.6 FLOTTEUR POUR NIVEAU DE BAC

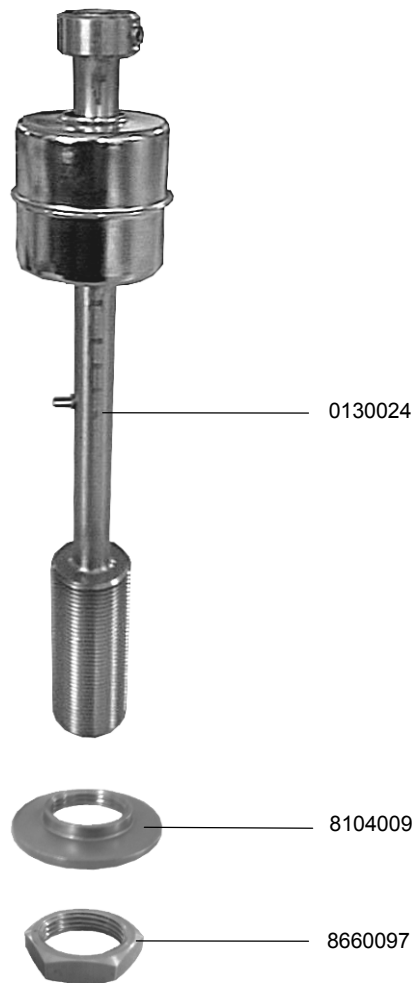

IDENT.-NR. IDENT.-NO.	BEZEICHNUNG	DESIGNATION	DESIGNATION
8660097	SKT. MUTTER 3/4"	HEXAGONE SCREW 3/4"	ECROU A 6 PANS 3/4"
8104009	MUTTER 3/4"	NUT 3/4"	ECROU 3/4"
* 0130024	SCHWIMMER	FLOAT	FLOTTEUR

16.1 KURVE 90°



16.1 CURVE 90°

16.1 COURBE 90°

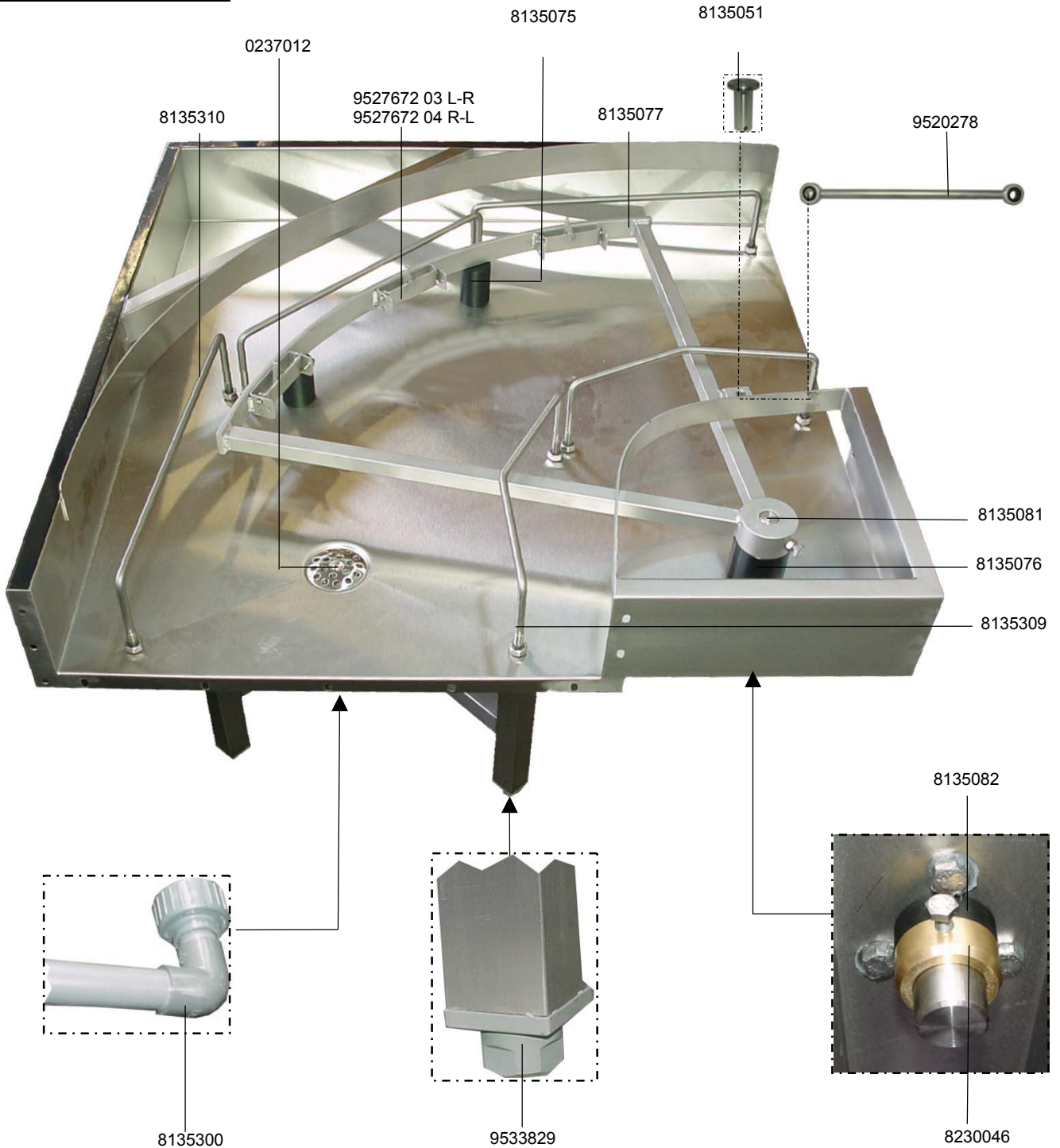

16.1 KURVE 90°



16.1 CURVE 90°

16.1 COURBE 90°

IDENT.-NR. IDENT.-NO.	BEZEICHNUNG	DESIGNATION	DESIGNATION
8135310	KORBGLEITBÜGEL	BASKET GUIDES	ARCHET GLISSANT POUR PANIER
0237012	UNIVERSALVENTIL	UNIVERSAL VALVE	SOUPAPE UNIVERSELLE
* 9527672 03	TRANSPORTKLINKE L-R	TRANSPORT RATCHET L-R	LOQUET DE TRANSPORT L-R
* 9527672 04	TRANSPORTKLINKE R-L	TRANSPORT RATCHET R-L	LOQUET DE TRANSPORT R-L
* 8135051	GELENKBOLZEN-KOPPELSTANGE	HINGED BOLT-COUPLING BAR	AXE D'ARTICULATION
8135077	ANTRIEBSRAD	DRIVE WHEEL	ROUE D'ENTRAINEMENT
V 8135075	AUFLAGER ET 90°	SUPPORT 90°	SUPPORT 90°
V 8135076	LAGERGEHÄUSE ET 90°	BEARING HOUSING	LOGEMENT DU PALIER
8135309	KORBGLEITBÜGEL	BASKET GUIDES	ARCHET GLISSANT POUR PANIER
* 9520278	KOPPELSTANGE	COUPLING BAR	ELEMENT DE COUPLAGE
8135081	ACHSE 20X125	AXLE 20X125	ESSIEU 20X125
V 8135082	DISTANZBUCHSE 30X30	CONNECTION RING 30X30	BAGUE DE CONNEXION 30X30
8230046	DISTANZRING	SPACER	DOVILLE DE ECARTEMENT
9533829	TISCHSTOLLEN KPL.	TABLE FEET COMPLET	PIEDS DE TABLE COMPLET
8135300	ABLAUFROHR ET 90°	OUTLET PIPE	ROBINET POUR L'ECOULEMENT DE L'EAU

16.2 KURVE 180°



16.2 CURVE 180°

16.2 COURBE 180°

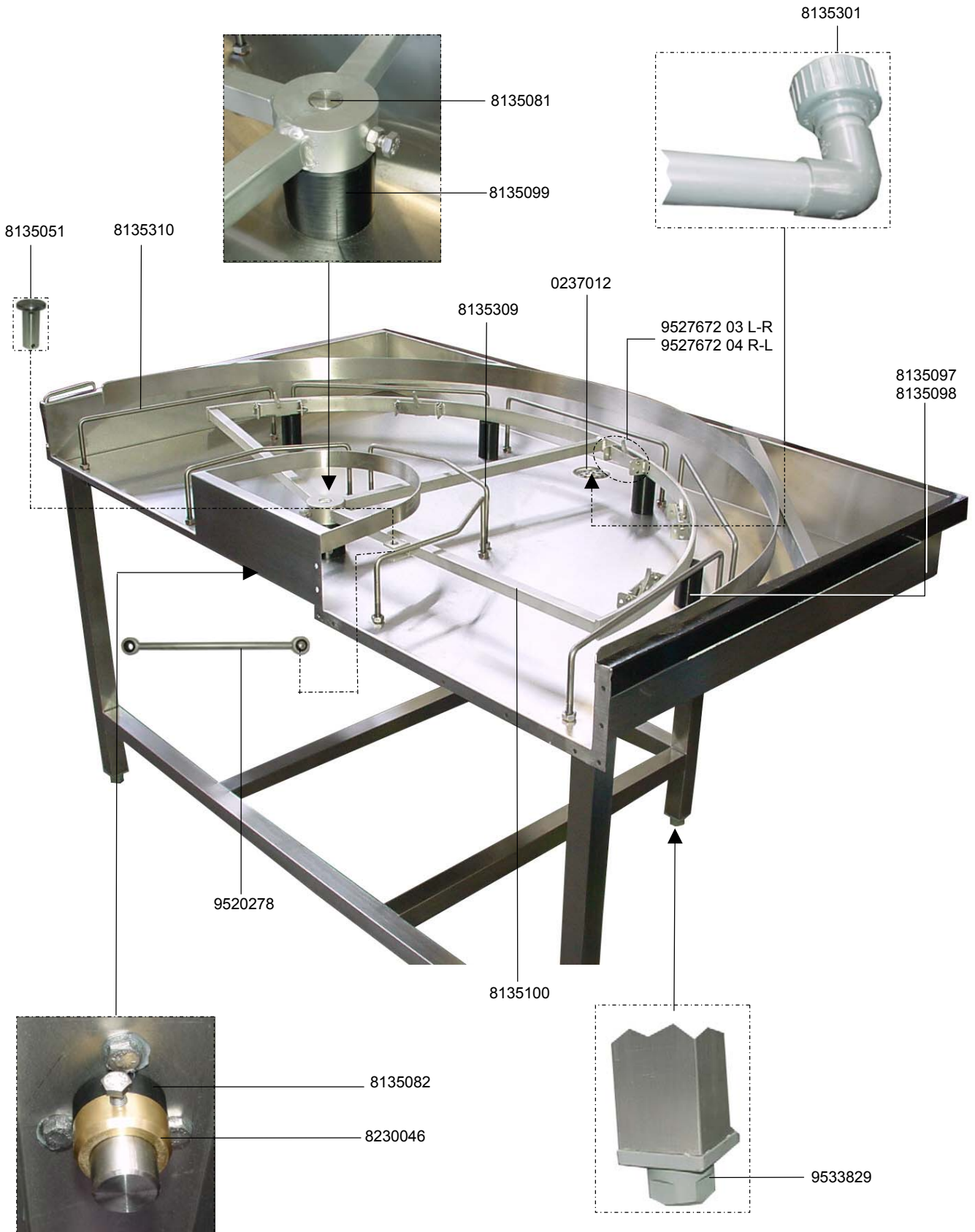

16.2 KURVE 180°



16.2 CURVE 180°

16.2 COURBE 180°

IDENT.-NR. IDENT.-NO.	BEZEICHNUNG	DESIGNATION	DESIGNATION
8135310	KORBGLEITBÜGEL	BASKET GUIDES	ARCHET GLISSANT POUR PANIER
8135081	ACHSE 20X125	AXLE	ESSIEU
V 8135099	LAGERGEHÄUSE ET 180°	BEARING HOUSING	LOGEMENT DU PALIER
8135309	KORBGLEITBÜGEL	BASKET GUIDES	ARCHET GLISSANT POUR PANIER
0237012	UNIVERSALVENTIL	UNIVERSAL VALVE	SOUPAPE UNIVERSELLE
* 9527672 03	TRANSPORTKLINKE L-R	TRANSPORT RATCHET L-R	LOQUET DE TRANSPORT L-R
* 9527672 04	TRANSPORTKLINKE R-L	TRANSPORT RATCHET R-L	LOQUET DE TRANSPORT R-L
8135301	ABLAUFROHR ET 180°	OUTLET PIPE	ROBINET POUR L'ÉCOULEMENT DE L'EAU
V 8135097	AUFLAGER ET 180°-66MM	SUPPORT 180°-66MM	SUPPORT 180°-66MM
V8135098	AUFLAGER ET 180°-72MM	SUPPORT 180°-72MM	SUPPORT 180°-72MM
9533829	TISCHSTOLLEN KPL.	TABLE CLEAT	CRAMPON DE LA TABLE
8135100	ANTRIEBSRAD	DRIVE WHEEL	ROUE D'ENTRAÎNEMENT
* 9520278	KOPPELSTANGE	COUPLING BAR	ELEMENT DE COUPLAGE
V 8135082	DISTANZBUCHSE 30X30	CONNECTION RING 30X30	BAGUE DE CONNEXION 30X30
8230046	DISTANZRING	TABLE FEET COMPLET	PIEDS DE TABLE COMPLET
* 8135051	GELENKBOLZEN-KOPPELSTANGE	HINGED BOLT-COUPLING BAR	AXE D'ARTICULATION