

DOMINATOR GAS RANGE APPLIANCES

Refer to Section 1 for models covered by this document

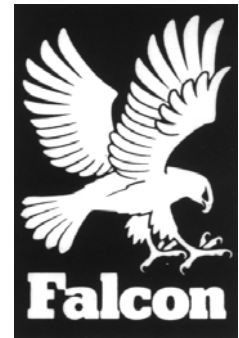

USERS INSTRUCTIONS

SECTION 1 - GENERAL DESCRIPTION

SECTION 2 - LIGHTING and OPERATIONS

SECTION 3 - USING THE APPLIANCE

SECTION 4 - CLEANING and MAINTENANCE

These appliances have been CE-marked on the basis of compliance with the Gas Appliance Directive for the Countries, Gas Types and Pressures as stated on the Data Plate.

These appliances MUST BE installed by a competent person in compliance with the INSTALLATION AND SERVICING INSTRUCTIONS and National Regulations in force at the time. Particular attention MUST be paid to the following:

Gas Safety (Installation & Use) Regulations

Health and Safety at Work Act

Furthermore, if a need arises to convert the appliance for use with another gas, a competent person must be consulted. Those parts which have been protected by the manufacturer MUST NOT be adjusted by the User.

Users should be conversant with the appropriate provisions of the Fire Precautions Act and the requirements of the Gas Safety Regulations. In particular the need for regular servicing by a competent person to ensure the continued safe and efficient performance of the Appliance.

WARNING - TO PREVENT SHOCKS, ALL APPLIANCES WHETHER GAS OR ELECTRIC, MUST BE EARTHED.

Upon receipt of the User's Instruction manual, the installer should instruct the responsible person(s) of the correct operation and maintenance of the Appliance.

This equipment is ONLY FOR PROFESSIONAL USE, and shall be operated by QUALIFIED persons. It is the responsibility of the Supervisor or equivalent to ensure that users wear SUITABLE PROTECTIVE CLOTHING and to draw attention to the fact that, some parts will, by necessity, become VERY HOT and will cause burns if touched accidentally.

Falcon Foodservice Equipment

HEAD OFFICE AND WORKS

PO Box 37, Foundry Loan, Larbert.
Stirlingshire. Scotland. FK5 4PL

AFE SERVICE CONTACT -

PHONE - 01438 751 111 FAX - 01438 369 900

RZZ 331 Ref. 1



AGA FOODSERVICE EQUIPMENT

SECTION 1 - GENERAL DESCRIPTION

This group of products consists of the following appliances.

G2101 and G2107 OT

Six Burner Open Top Ranges

G2161 and G2167 OT

Four Burner Open Top Ranges

G2107 SB Solid Top Range

G2121 OT Six Burner Open Top Boiling Table

G2124 Four Burner Open Top Boiling Table

G2127 SB Solid Top Boiling Table

G2117 General Purpose Oven

All models are fitted with flame failure devices to shut off gas supply to burners if flames are extinguished.

The ovens are thermostatically controlled.

Controls

All taps are the safety type with fixed HIGH and LOW settings. The operation sequences of the taps are shown in Figure 1.

Figure 1 - Open Top Gas Tap

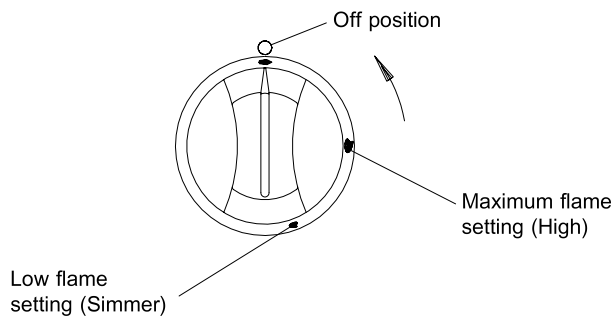

Hob Burner Indication

Each tap may be identified with the corresponding burner as illustrated below -.



Solid Top

The solid hotplate is composed of two filling plates, a ring and centre bullseye. A double-ring burner is located below hotplate and is operated by a control knob on fascia panel indicated by symbol shown in Figure 2.

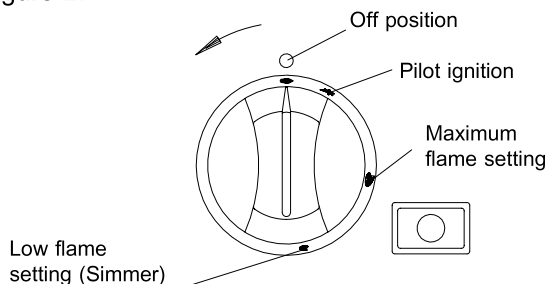
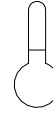

Figure 2 - Solid Top Gas Tap

Oven Thermostat

The oven is thermostatically controlled. This control is identified by the symbol illustrated below.



Note

Spark ignition button is located below oven compartment.

Oven doors must be opened to gain access to device.

SECTION 2 - LIGHTING and OPERATIONS

Open Top

1. Press and turn knob to full flame position.
2. Light burner using taper or match and continue to press knob for a further 20 seconds before release.
3. Burner should remain lit; if burner goes out return to Step 1 and repeat ignition procedure.
4. When burner remains lit, turn knob to required position.

To Shut the Open Top OFF

Turn knob to OFF position.

Solid Top

1. Ensure mains gas is turned on.
2. Remove bullseye castings from solid top hob.
3. Turn control anti-clockwise to pilot ignition position and push knob in.
4. Holding knob in fully, apply taper to pilot and observe pilot lights.
5. When pilot is lit, continue to hold knob in fully for 20 seconds then release. If pilot is extinguished, wait three minutes and repeat from Step 3.
6. Having established pilot condition, turn knob anti-clockwise to FULL FLAME position. This will light main burner.
7. For LOW FLAME operation, turn knob further anti-clockwise to LOW FLAME position.
8. Replace bullseye castings.

To Shut the Solid Top OFF

1. Turn to pilot position, ready for next operation.
2. To extinguish completely, turn to OFF position.

Oven

1. Open oven doors.
2. Turn thermostat knob to maximum setting and push in. This will establish a flow of gas to oven burner.
3. Continue to press knob in and at the same time, push piezo ignitor button situated below oven compartment to provide a spark at oven burner.
4. Having established burner flame, maintain pressure on knob for a further 20 seconds before release.
5. Burner should remain lit. Should burner fail to remain lit, wait 2 to 3 minutes then return to Step 2 and repeat ignition procedure.
6. When burner remains lit, turn thermostat to required position.

To Shut the Oven OFF

To extinguish burner, turn thermostat control knob to OFF position.

SECTION 3 - COOKING HINTS

Open Top

Open top burners are rated at 4.5kW nett.

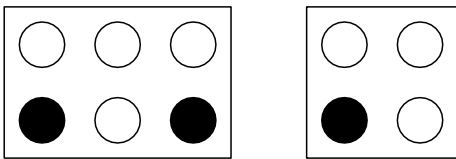

Boost burner (5.3kW) positions are indicated here for models - G2101, G2121, G2161 and G2124.

The pan supports will safely accommodate pans from 125mm diameter. It is recommended however, that pans larger than 300mm diameter be heated upon the rear burners.

Solid Top

It is normal practice to leave the single burner full on for the whole of the time the hotplate is in use.

As much of the heat is concentrated in the centre, tapering away towards the edges, this area should be used for rapid boiling. The pan then moved away from main heat source to simmer at desired intensity.

Hints on Using Solid Hotplate

Getting the best out of this type of heat source is largely a matter of experience coupled with the needs of a particular task in hand. For certain applications, such as heating a pot quickly, it will be found expedient to remove centre ring and place pot directly over burner. If it is necessary to heat the entire surface, the ring must be in position. In the interests of fuel economy, it is recommended that the solid top should not be left unattended with gas on FULL setting. If it is necessary to keep the top hot for any length of time, the control should be turned down to low flame setting.

Do not at any time leave the gas on without a pot whilst the centre ring is removed - such practice simply wastes gas.

The hottest area of the plate is at the centre and towards the rear. The front and sides are cooler.

Oven

Temperature is automatically controlled by the thermostat.

Grid Shelves

Two cooking shelves are supplied which can be supported in any of five different positions within the oven. When two shelves are being used, these should be positioned so that at least one single shelf space is left between them. Always push shelves into oven until the stops hit the front of the supports.

Tray Sizes

Each shelf will accommodate a 2/1 gastronorm tray. Single trays or dishes should be placed centrally. Trays must not be allowed to overhang the shelf in any direction as this will adversely affect heat circulation.

Pre-Heat Time

Allow at least 45 minutes from lighting a cold oven before loading with food to be cooked. Put food in quickly and close the doors firmly.

Oven Cooking Chart

This information is provided as guidance only and all figures are approximate. Due to the natural heat gradient in this type of oven, it will be necessary to interchange products on the upper and lower cooking shelves during the cooking period.

The changeover timing varies depending on product type, weight and temperature.

Food Product	Total Quantity	Total Weight (kg)	Temperature Setting (°C)	Runner Positions	Changeover Time (mins)	Total Cook Time (mins)
Vol-au-vents (medium)	80	1.1	230	2 & 4	10	16
Sultana scones (1 1/2")	80	4.5	240	2 & 4	9	14
Croissants (55g)	36	2	200	2 & 4	12	20
Bread rolls (75g)	48	3.6	230	2 & 4	10	17
Quiche lorraine (8" dia - 680g)	12	8.2	195	2 & 4	35	60
Yorkshire Pudding	72	2.7	240	3 & 5	18	32
Sponge (slab)	4	5.5	200	2 & 4	12	24
Baked jacket potatoes	72	26.5	220	2 & 4	70	110

SECTION 4 - CLEANING and MAINTENANCE

All surfaces are easier to clean if spillage is removed before it becomes burnt on and if unit is cleaned daily.

Stainless Steel Surfaces

These surfaces should be cleaned with hot water and detergent then dried and polished with a soft cloth.

Cleaning agents containing bleach, abrasives or caustic chemicals will damage or stain the stainless steel surfaces and must not be used.

Vitreous Enamel Surfaces

Approved cleaning agents which have the mark of the Vitreous Enamel Development Centre are recommended.

It is advisable to clean daily after use. Wipe clean the vitreous enamel surfaces while they are still warm using a soft cloth and hot soapy water. Badly stained, removable parts should be soaked in hot water with an approved detergent. If the parts are not removable from the unit the application of warm water with approved detergent using nylon or scotch cleaning pads will give good results.

Solid Top

The hob fillings can be lifted off the range for cleaning with warm soapy water, only using abrasives such as nylon cleaning pads for extreme overspill. Remove all accumulated debris which may be gathered in the burner tray and the ledge which supports the fillings.

Warning

Since the fillings are very heavy, care should be taken when handling them.

Open Top

Remove pan supports and burner head from unit. Wash all parts with hot soapy water. After washing, dry all parts well and ensure all water is removed from inside the burner head. Wipe out hob area and drip trays before replacing all parts in reverse order. Ensure that all burner parts are located correctly.

Oven

To Clean The Oven

Clean while oven is warm but not hot. The enamelled base plate lifts out. The runners can be removed, (grip at the bottom, lift upwards until the lower ends come out of the brackets, pull outward towards centre of oven, then lower). Two oven drip trays are provided and these are simply removed without disturbing burner, by sliding them out from the front.

CLEANING INSTRUCTIONS for OPEN TOP BURNERS

The following instructions should be followed when :

- A spillage has occurred on the burner.
- The burner fails to light or stay alight.
- At the end of each day or cooking period.

Caution

Parts may be hot therefore protection to avoid burns should be used.

- Remove the pan support.
- Remove the burner head by lifting upward.

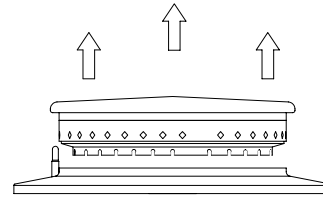

Figure 3

- Thoroughly clean with soap and water. Ensure that all burner ports are clean and free from food or cleaning material debris.

Important

Stubborn debris lodged in ports (See Figure 4) can be removed using a non-metallic implement such as a cocktail stick. The slots in the base should be freed of debris using a soft brush.

Dry burner with a lint-free cloth and blow through the ports to ensure there is no blockage.

Figure 4

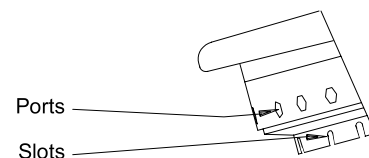

- Clean any spillage from burner base, ensuring all food and cleaning material debris is removed. Dry burner base thoroughly, taking care not to damage the flame sensor.

Flame Sensor

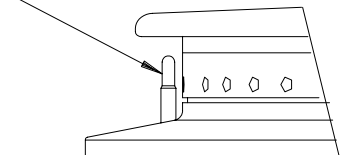
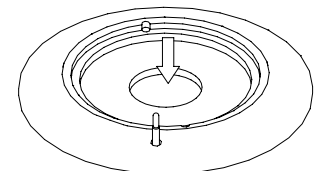

Figure 5

Important

Do not allow any spillage or cleaning material debris enter the large hole in the burner base.

Figure 6



- Replace burner head upon burner base and ensure the head location pins sit within the burner base notches. When burner head is properly located, it will not rotate.

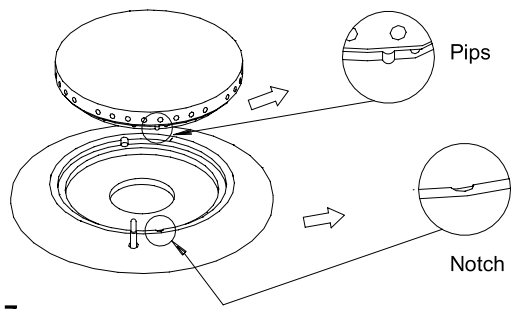

Figure 7

6. Light the burner to check that it operates correctly.

Note

This process should be followed prior to calling for a Service Engineer. Failure due to lack of proper cleaning is not covered by warranty.