

**CORTADORAS DE FIAMBRE**  
**GC-220 / GC-250 / GC-275 / GC-300**
**SLICERS**  
**GC-220 / GC-250 / GC-275 / GC-300**
**TRANCHEUSES**  
**GC-220 / GC-250 / GC-275 / GC-300**

N.	Denominación	Description	Dénomination	Cod.
1a	Juego piedras afilar (220, 250)	Grinding abrasive (220, 250)	Ensemble pierre à aiguiser (220, 250)	6052590
1b	Juego piedras afilar (275, 300)	Grinding abrasive (275, 300)	Ensemble pierre à aiguiser (275, 300)	6052599
2a	Conjunto afilador (220, 250)	Sharpener set (220, 250)	Ensemble aiguiser (220, 250)	6052501
2b	Conjunto afilador (275, 300)	Sharpener set (275, 300)	Ensemble aiguiser (275, 300)	6052502
3a	Soporte afilador (220)	Sharpener holder (220)	Support aiguiser (220)	6052650
3b	Soporte afilador (250, 275, 300)	Sharpener holder (250, 275, 300)	Support aiguiser (250, 275, 300)	6052652
4a	Soporte placa apoyo (250, 275)	Fence support (250, 275)	Support butée (250, 275)	6052629
4b	Soporte placa apoyo (300)	Fence support (300)	Support butée (300)	6052631
5a	Conjunto interruptor (220)	Switch set (220)	Ensemble interrupteur (220)	6052572
5a	Conjunto interruptor (250, 275, 300)	Switch set (250, 275, 300)	Ensemble interrupteur (250, 275, 300)	6052581
5b	Pulsador parada-marcha	Start-stop pushbutton	Bouton arrêt-marche	6052641
5c	Interruptor CE	Switch CE	Interrupteur CE	6052582
6a	Mando regulador corte (220)	Slicing control knob (220)	Commande vernier gradué (220)	6052612
6b	Mando regulador corte (250, 275)	Slicing control knob (250, 275)	Commande vernier gradué (250, 275)	6052614
6c	Mando regulador corte (300)	Slicing control knob (300)	Commande vernier gradué (300)	6052613
7a	Regulador corte (220)	Slicing regulator (220)	Vernier gradué (220)	6052512
7b	Regulador corte (250,275,300)	Slicing regulator (250,275,300)	Vernier gradué (250,275,300)	6052510
8	Condensador	Condenser	Condensateur	6052509
9a	Motor (220)	Motor (220)	Moteur (220)	6052617
9b	Motor (250,275,300)	Motor (250, 275, 300)	Moteur (250,275,300)	6052626
10a	Conjunto soporte cuchilla (220)	Blade support set (220)	Ensemble support lame (220)	6052665
10b	Conjunto sop. cuchilla (250,275,300)	Blade support set (250, 275, 300)	Ensemble support lame (250,275,300)	6052667
11a	Correa (220,250)	Belt (220, 250)	Courroie (220,250)	6052518
11b	Correa (275)	Belt (275)	Courroie (275)	6052520
11c	Correa (300)	Belt (300)	Courroie (300)	6052527
12a	Cuchilla (220)	Blade (220)	Lame (220)	6052536
12b	Cuchilla (250)	Blade 250	Lame (250)	6052545
12c	Cuchilla (275)	Blade (275)	Lame (275)	6052554
12d	Cuchilla (300)	Blade (300)	Lame (300)	6052563
13a	Cubre-cuchilla (220)	Blade guard (220)	Protège-lame (220)	6052530
13b	Cubre-cuchilla (250)	Blade guard (250)	Protège-lame (250)	6052532
13c	Cubre-cuchilla (275)	Blade guard (275)	Protège-lame (275)	6052533
13d	Cubre-cuchilla (300)	Blade guard (300)	Protège-lame (300)	6052534
14a	Conjunto brazo pisador (220)	Carriage handle set (220)	Ensemble poignée du charriot (220)	6052506
14b	Conjunto brazo pisador (250, 275)	Carriage handle set (250, 275)	Ens. poignée du charriot (250, 275)	6052508
14c	Conjunto brazo pisador (300)	Carriage handle set (300)	Ensemble poignée du charriot (300)	6052514
15a	Deslizador de carro (220)	Arm bushing set (220)	Flasque porteur du charriot (220)	6052511
15b	Deslizador de carro (250, 275)	Arm bushing set (250, 275)	Flasque porteur du charriot (250,275)	6052513
15c	Deslizador de carro (300)	Arm bushing set (300)	Flasque porteur du charriot (300)	6052515
16a	Pomo sujeción carro (220)	Carriage knob (220)	Commande du charriot (220)	6052639
16b	Pomo sujeción carro (250, 275, 300)	Carriage knob (250, 275, 300)	Commande du charriot (250,275,300)	6052636
17	Juego patas	Feet set	Ensemble pieds	6052638
18a	Bandeja (220)	Tray (220)	Plateau (220)	6052503
18b	Bandeja (250, 275)	Tray (250, 275)	Plateau (250, 275)	6052504
18c	Bandeja (300)	Tray (300)	Plateau (300)	6052505
19	Manilla bandeja	Tray handle	Poignée plateau	6052610
20a	Placa de apoyo (220)	Back plate (220)	Back plate (220)	6052622
20b	Placa de apoyo (250)	Back plate (250)	Back plate (250)	6052623
20c	Placa de apoyo (275)	Back plate (275)	Back plate (275)	6052624
20d	Placa de apoyo (300)	Back plate (300)	Back plate (300)	6052625
21a	Rascador (220)	Scraper (220)	Racleur (220)	6052643
21b	Rascador (250)	Scraper (250)	Racleur (250)	6052642
21c	Rascador (275)	Scraper (275)	Racleur (275)	6052644
21d	Rascador (300)	Scraper (300)	Racleur (300)	6052640
22a	Soporte bandeja (220)	Tray holder (220)	Support plateau (220)	6052654
22b	Soporte bandeja (250, 275)	Tray holder (250, 275)	Support plateau (250, 275)	6052656
22c	Soporte bandeja (300)	Tray holder (300)	Support plateau (300)	6052658
23a	Manilla pisador	Pusher lever	Poignée pousse-talon	6052627
24a	Tirante con roseta (220)	Rosette tie (220)	Tirant avec bouton moleté (220)	6052615
24b	Tirante con roseta (250, 275)	Rosette tie (250, 275)	Tirant avec bouton moleté (250, 275)	6052616
24c	Tirante con roseta (300)	Rosette tie (300)	Tirant avec bouton moleté (300)	6052618
25	Protector transparente	Transparent guard	Fronteau de sécurité	6052645

GC-220 / GC-250 / GC-275 / GC-300

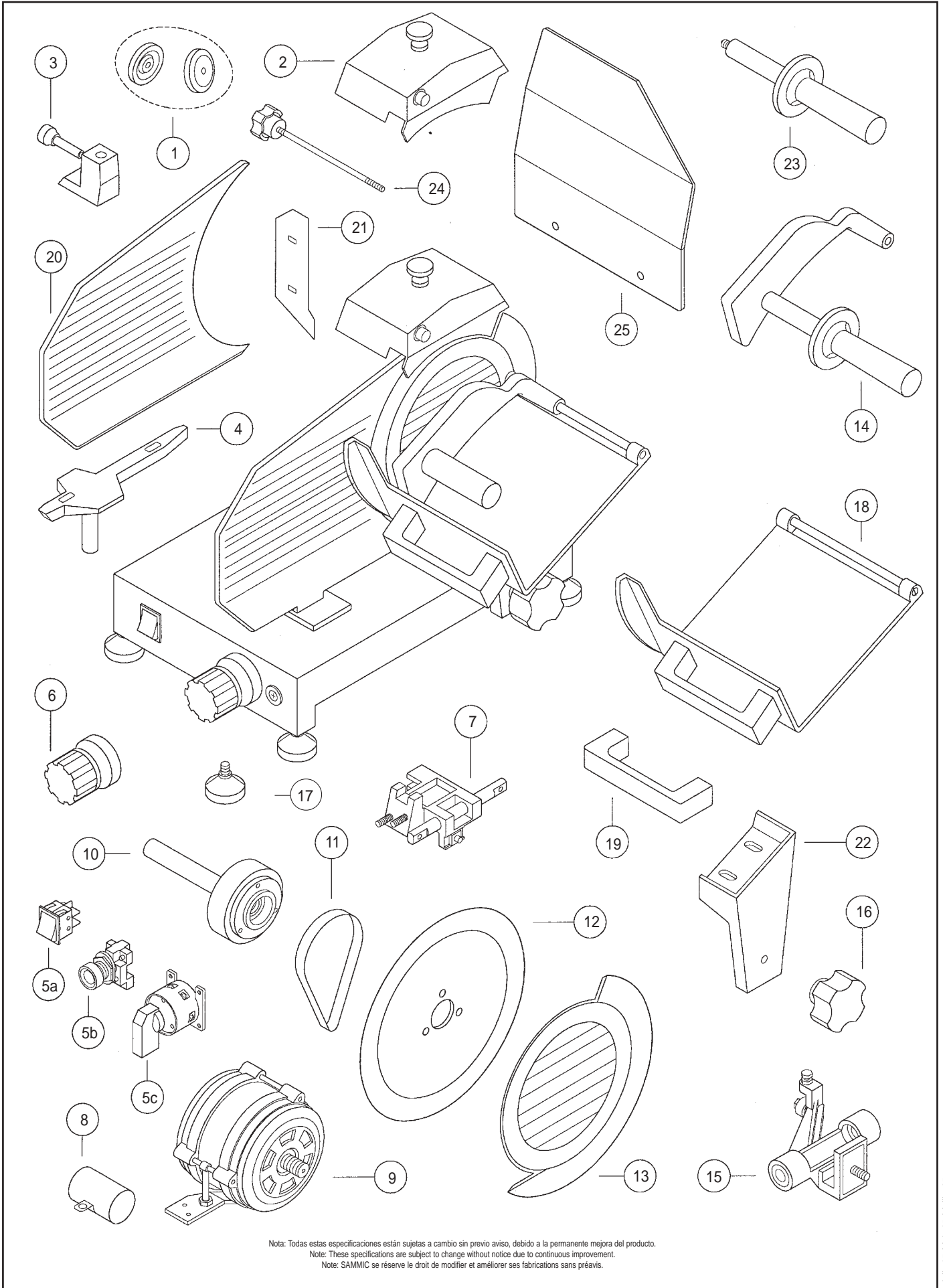

Nota: Todas estas especificaciones están sujetas a cambio sin previo aviso, debido a la permanente mejora del producto.  
 Note: These specifications are subject to change without notice due to continuous improvement.  
 Note: SAMMIC se réserve le droit de modifier et améliorer ses fabrications sans préavis.