

International Commercial Microwave—Technical Information

230 V, 50 Hz Models

HDC5112	P1331211M	UHDC5112	P1331212M
HDC5142	P1331215M	UHDC5142	P1331216M
HDC5182	P1331219M	UHDC5182	P1331220M
DEC11E2	P1331213M	UC11E2	P1331214M
DEC14E2	P1331217M	DEC18E2	P1331221M
UC14E2	P1331218M	UC18E2	P1331222M

- Due to possibility of personal injury or property damage, always contact an authorized technician for servicing or repair of this unit.
- Refer to Service Manual RS5320013 for detailed installation, operating, testing, troubleshooting, and disassembly instructions.

CAUTION

All safety information must be followed as provided in Service Manual RS5320013.

WARNING









To avoid risk of electrical shock, personal injury, or death, disconnect power to oven and discharge capacitor before servicing, unless testing requires power.

Models	UHDC5112 UC11E2	HDC5112 DEC11E2	UHDC5142 UC14E2	HDC5142 DEC14E2	UHDC5182 UC18E2	HDC5182 DEC18E2
Power Source						
Voltage AC	230 VAC	230 VAC	230 VAC	230 VAC	230 VAC	230 VAC
Amperage (single unit)	13 A	13 A	13 A	13 A	13 A	13 A
Frequency	50 Hz	50 Hz	50 Hz	50 Hz	50 Hz	50 Hz
Single phase, 3 wire earthed	X	X	X	X	X	X
Plug	BS 1363A	CEE 7/7 Schuko	BS 1363A	CEE 7/7 Schuko	BS 1363A	CEE 7/7 Schuko
Power Output						
Nominal microwave energy (IEC705)	1100 Watts	1100 Watts	1400 Watts	1400 Watts	1800 Watts	1800 Watts
Minimum temperature rise (ΔT)	11°F/5.5°C	11°F/5.5°C	14°F/7.5°C	14°F/7.5°C	18°F/10°C	18°F/10°C
Operating frequency	2450 MHz	2450 MHz	2450 MHz	2450 MHz	2450 MHz	2450 MHz
Power Consumption						
Cook condition microwave	1800 Watts	1800 Watts	2300 Watts	2300 Watts	3000 Watts	3000 Watts
Dimensions						
Cabinet						
Width	423 mm	423 mm	423 mm	423 mm	423 mm	423 mm
Height	335 mm	335 mm	335 mm	335 mm	335 mm	335 mm
Depth	548 mm	548 mm	578 mm	578 mm	578 mm	578 mm
Oven Interior						
Width	331 mm	331 mm	331 mm	331 mm	331 mm	331 mm
Height	175 mm	175 mm	175 mm	175 mm	175 mm	175 mm
Depth	305 mm	305 mm	305 mm	305 mm	305 mm	305 mm
Weight						
Crated	29 kg	29 kg	31 kg	31 kg	31 kg	31 kg

Component Specifications

⚠ WARNING

To avoid risk of electrical shock, personal injury, or death, disconnect power to oven and discharge capacitor before servicing, unless testing requires power.

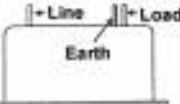
Illustration	Component	Testing	Results
	Thermal Cutout	Disconnect all wires from TCO. Measure resistance across terminals. Cavity Thermal Fuse Magnetron TCO	Open at 104° C (219° F). Open at 138° C (280° F) and closed at 82° C (180° F).
1100 Watt units  1400 and 1800 Watt units 	Diode Assembly	Discharge Capacitors Remove diode lead from capacitor and connect ohmmeter. Reverse leads for second test.	Infinite resistance should be measured in one direction and 50KΩ or more in the opposite direction. NOTE: Analog meter must contain a battery of 6 volts minimum.
	Triac	Disconnect wires to triac. Measure resistance from: MT1 to MT2 MT1 to Gate MT2 to Gate All terminals to ground	Caution - Do not operate oven when wire to terminal MT2 is removed. Infinite. Approximately 40 Ω or more. Infinite. Infinite.
	Capacitor	Discharge Capacitors Remove wires from capacitor terminals and connect ohmmeter, set on highest resistance scale to terminals. Also check between each terminal and capacitor case.	Between Terminals: Meter should momentarily deflect towards zero then return to over 5 MΩ. If no deflection occurs, or if continuous deflection occurs, replace capacitor. Terminal to Case: Infinite resistance.
	Snubber Assembly	Disconnect wires to snubber. Measure resistance across terminals.....	Infinite.
	Magnetron	Discharge Capacitors Remove wires from magnetron and connect ohmmeter to terminals. Also check between each terminal and ground.	Between Terminals: Less than 1 Ω. Each terminal to ground measures Infinite resistance. NOTE: This test is not conclusive. If oven does not heat and all other components test good, replace the magnetron and retest.
	Blower Motor	Remove all wires from motor. Measure resistance across coil.....	Approximately 30 Ω.
	Line filter	Line to Line Load to Load Line to Load Any terminal to Earth8 MΩ. .8 MΩ. Continuity. Infinite.
Wire Harness		Test continuity of wires	Continuity.

Component Specifications

⚠ WARNING

To avoid risk of electrical shock, personal injury, or death, disconnect power to oven and discharge capacitor before servicing, unless testing requires power.

Illustration	Component	Testing	Results																																																
	Transformer 1100 Watt 	Discharge Capacitor Remove all wires from terminals, and measure resistance from: 220 to Common 230 to Common Terminal 5 to 6 Terminal 4 to Earth screw on transformer Terminal 4 to any other terminal 	This transformer is equipped with a 155° C thermal cutout. 1.3 Ω. 1.3 Ω. <1 Ω. 70 Ω. Infinite resistance. If not, replace transformer.																																																
	Transformer 1800 and 1400 Watt 	Discharge Capacitor Remove all wires from terminals, and measure resistance from: 230 to Common Terminal 5 to 6 Terminal 7 to 8 Terminal 4 to Earth screw on transformer Terminal 4 to any other terminal	1 Ω. <1 Ω. <1 Ω. 45 Ω. Infinite resistance. If not, replace transformer.																																																
	Stirrer motor	Remove all wires from motor. Measure resistance across terminals	Approximately 12 KΩ.																																																
	Interlock switch assembly	Disconnect wires to switch. With door open measure resistance from: Terminal C to NO Primary Terminal C to NO Secondary Terminal C to NC Monitor With door closed measure resistance from: Terminal C to NO Primary Terminal C to NO Secondary Terminal C to NC Monitor 	Infinite. Infinite. Continuity. Continuity. Continuity. Infinite.																																																
	Touch Panel Assembly	Continuity is indicated as 100 Ω and below. Pin 1: Ground. 	<table border="1"> <thead> <tr> <th>Pad</th> <th>Trace</th> <th>Measurement</th> </tr> </thead> <tbody> <tr><td>1</td><td>8 & 10</td><td>Continuity</td></tr> <tr><td>2</td><td>7 & 10</td><td>Continuity</td></tr> <tr><td>3</td><td>6 & 10</td><td>Continuity</td></tr> <tr><td>4</td><td>5 & 10</td><td>Continuity</td></tr> <tr><td>5</td><td>4 & 10</td><td>Continuity</td></tr> <tr><td>6</td><td>3 & 10</td><td>Continuity</td></tr> <tr><td>7</td><td>8 & 9</td><td>Continuity</td></tr> <tr><td>8</td><td>7 & 9</td><td>Continuity</td></tr> <tr><td>9</td><td>6 & 9</td><td>Continuity</td></tr> <tr><td>0</td><td>5 & 9</td><td>Continuity</td></tr> <tr><td>Start</td><td>4 & 9</td><td>Continuity</td></tr> <tr><td>Stop/Reset</td><td>4 & 8</td><td>Continuity</td></tr> <tr><td>Power Level</td><td>5 & 8</td><td>Continuity</td></tr> <tr><td>X 2</td><td>6 & 8</td><td>Continuity</td></tr> <tr><td>Time Entry</td><td>7 & 8</td><td>Continuity</td></tr> </tbody> </table>	Pad	Trace	Measurement	1	8 & 10	Continuity	2	7 & 10	Continuity	3	6 & 10	Continuity	4	5 & 10	Continuity	5	4 & 10	Continuity	6	3 & 10	Continuity	7	8 & 9	Continuity	8	7 & 9	Continuity	9	6 & 9	Continuity	0	5 & 9	Continuity	Start	4 & 9	Continuity	Stop/Reset	4 & 8	Continuity	Power Level	5 & 8	Continuity	X 2	6 & 8	Continuity	Time Entry	7 & 8	Continuity
Pad	Trace	Measurement																																																	
1	8 & 10	Continuity																																																	
2	7 & 10	Continuity																																																	
3	6 & 10	Continuity																																																	
4	5 & 10	Continuity																																																	
5	4 & 10	Continuity																																																	
6	3 & 10	Continuity																																																	
7	8 & 9	Continuity																																																	
8	7 & 9	Continuity																																																	
9	6 & 9	Continuity																																																	
0	5 & 9	Continuity																																																	
Start	4 & 9	Continuity																																																	
Stop/Reset	4 & 8	Continuity																																																	
Power Level	5 & 8	Continuity																																																	
X 2	6 & 8	Continuity																																																	
Time Entry	7 & 8	Continuity																																																	

Component Specifications



WARNING

To avoid risk of electrical shock, personal injury, or death, disconnect power to oven and discharge capacitor before servicing, unless testing requires power.

Illustration	Component	Testing	Results
<p>P2 Pin #1</p> <p>P1 Pin #1</p>	<p>Controller board</p> <p>P2</p> <p>P1</p> <p>P1 connector used for touch panel ribbon</p>	<p>Line voltage to control board P2 connector Pin 1—Pin 3.....</p> <p>Output drive voltage to triac Triac terminals..... Gate—T1.....</p> <p>Fan relay (controls blower motor, antenna motor(s), and oven light) Control board..... Terminals C—J.....</p> <p>Cook relay Control board..... Terminals F—K.....</p>	<p>Line voltage (All Conditions)</p> <p>0 VAC (Idle and Standby) 0.9 VAC (Cook)</p> <p>Line voltage (Idle) 0 VAC (Standby and Cook)</p> <p>Line voltage (Idle) 0 volts (Standby and Cook)</p>

Error Code Table

Error Code	Corrective Action
F1	Replace HV/LV Board
F2	Replace HV/LV Board
F3	Replace HV/LV Board
F4	Replace Touch Panel
F5	Replace HV/LV Board

Usage Test

The Usage Test is used to access Magnetron Hours, Magnetron Cycles and Door Cycles. Use the following procedure to access the data:

1. Open door.
 2. Press and hold pad 3 for five (5) seconds.
- NOTE:** After five (5) seconds, SErv illuminates in the display.
3. Press pad 1 for Magnetron Hours.
 4. Press pad 2 for Magnetron Cycles.
 5. Press pad 3 for Door Cycles.

Conditions

Initial Power Up Condition:	Apply power to oven with door closed.
Idle Condition:	Oven plugged in, display blank (no other components operating).
Standby Condition:	Open oven door, light and motors operate.
Cook Condition:	Food load in oven, cook cycle initiated.

Component Specifications



WARNING

To avoid risk of electrical shock, personal injury, or death, disconnect power to oven and discharge capacitor before servicing, unless testing requires power.

Power Test

All Amana and Menumaster microwave oven power outputs are rated using the IEC705 standards. Using the IEC705 test method requires precision measurements and equipment that is not practical to be performed in the field. Using the test shown below will indicate if the oven performance is satisfactory.

Test equipment required:

- 1000 ml test container and thermometer (Amana power test kit R0157397 Fahrenheit / Menumaster power test kit M95D5 Celsius).
- Digital watch / watch with a second hand for use on ovens with electromechanical timers.

Important Notes:

- Low line voltage will cause low temperature rise / power output.
- Ovens must be on a dedicated circuit, properly grounded, and polarized. Other equipment on the same circuit may cause a low temperature rise / power output.
- This test and results are not a true IEC705 test procedure and are only intended to provide servicers with an easy means of determining if the microwave oven cooking output is correct.

Procedure

1. Fill the test container to the 1000 ml line with cool tap water.

NOTE: Water temperature should be approximately 60° F / 16° C.

2. Using the thermometer, stir water for five to ten seconds; measure, and record the temperature (T1).
3. Place test container of water in the center of oven cavity and close door.
4. Heat the water for a 33-second full power cycle.

NOTE: Use a digital watch or a watch with a second hand for ovens with electromechanical timers.

1. At end of the cycle, remove test container. Using the thermometer, stir water for five to ten seconds and record temperature (T2).
2. Subtract the starting water temperature (T1), from the ending water temperature (T2) to obtain the temperature rise (ΔT).
3. If the temperature rise (ΔT) meets or exceeds the minimum, the test is complete. If the temperature rise (ΔT) fails to meet the minimum temperature rise, test the line voltage to verify it is correct. Then repeat steps 1-6 making sure to change the water. If the temperature rise (ΔT) fails to meet the minimum temperature rise again the oven will require service.

Minimum Temperature Rise at Thirty-Three (33) Seconds Run Time

ΔT (°F)	Cooking Power Output	ΔT (°F)	Cooking Power Output	ΔT (°C)	Cooking Power Output	ΔT (°C)	Cooking Power Output
10	1000	20	2000	5	1000	11	2000
11	1100	21	2100	5.5	1100	11.5	2100
12	1200	22	2200	6.5	1200	12	2200
14	1400	24	2400	7.5	1400	13	2400
17	1700	25	2500	9.5	1700	13.5	2500
18	1800	27	2700	10	1800	15	2700
19	1900	30	3000	10.5	1900	16.5	3000

Wiring and Schematic Diagrams

⚠ WARNING

To avoid risk of electrical shock, personal injury, or death, disconnect power to oven and discharge capacitor before servicing, unless testing requires power.

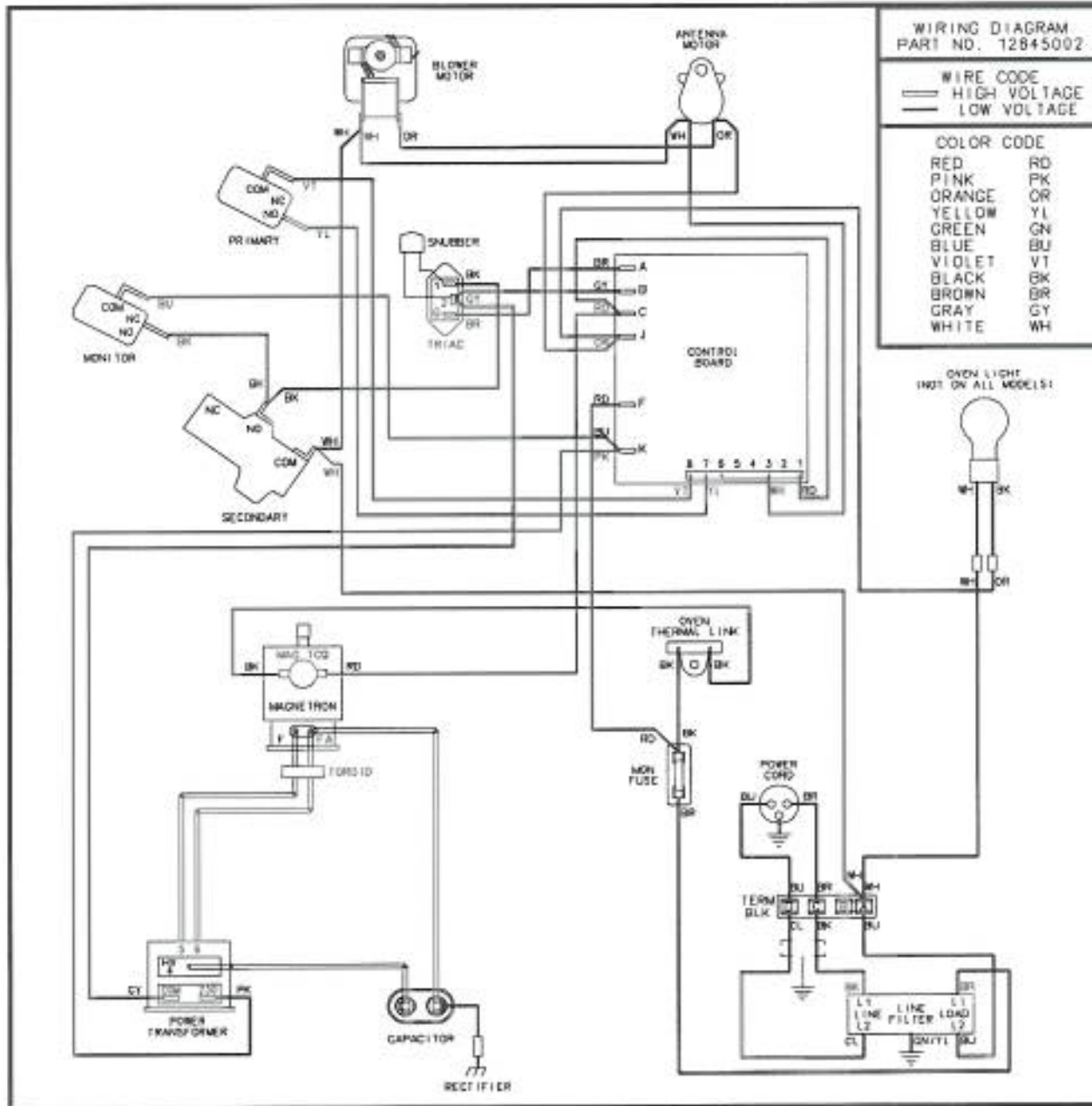

12845002

HDC5112
DEC11E2

P1331211M
P1331213M

UHDC5112
UC11E2

P1331212M
P1331214M

Wiring and Schematic Diagrams

WARNING

To avoid risk of electrical shock, personal injury, or death, disconnect power to oven and discharge capacitor before servicing, unless testing requires power.

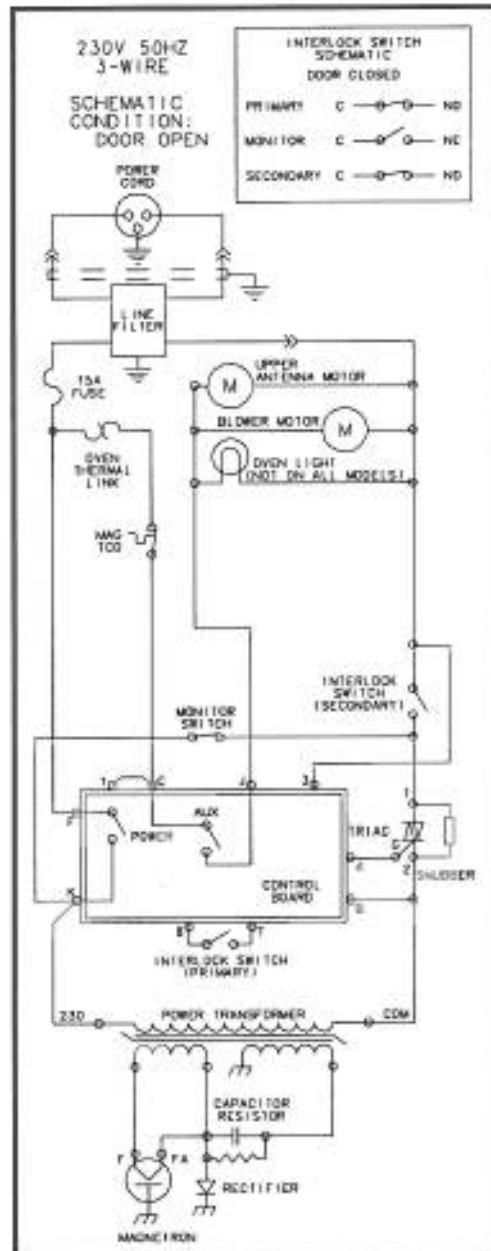

12845002

 **DANGER**
HIGH VOLTAGE

HDC5112
DEC11E2

P1331211M
P1331213M

UHDC5112
UC11E2

P1331212M
P1331214M

Wiring and Schematic Diagrams

⚠ WARNING

To avoid risk of electrical shock, personal injury, or death, disconnect power to oven and discharge capacitor before servicing, unless testing requires power.

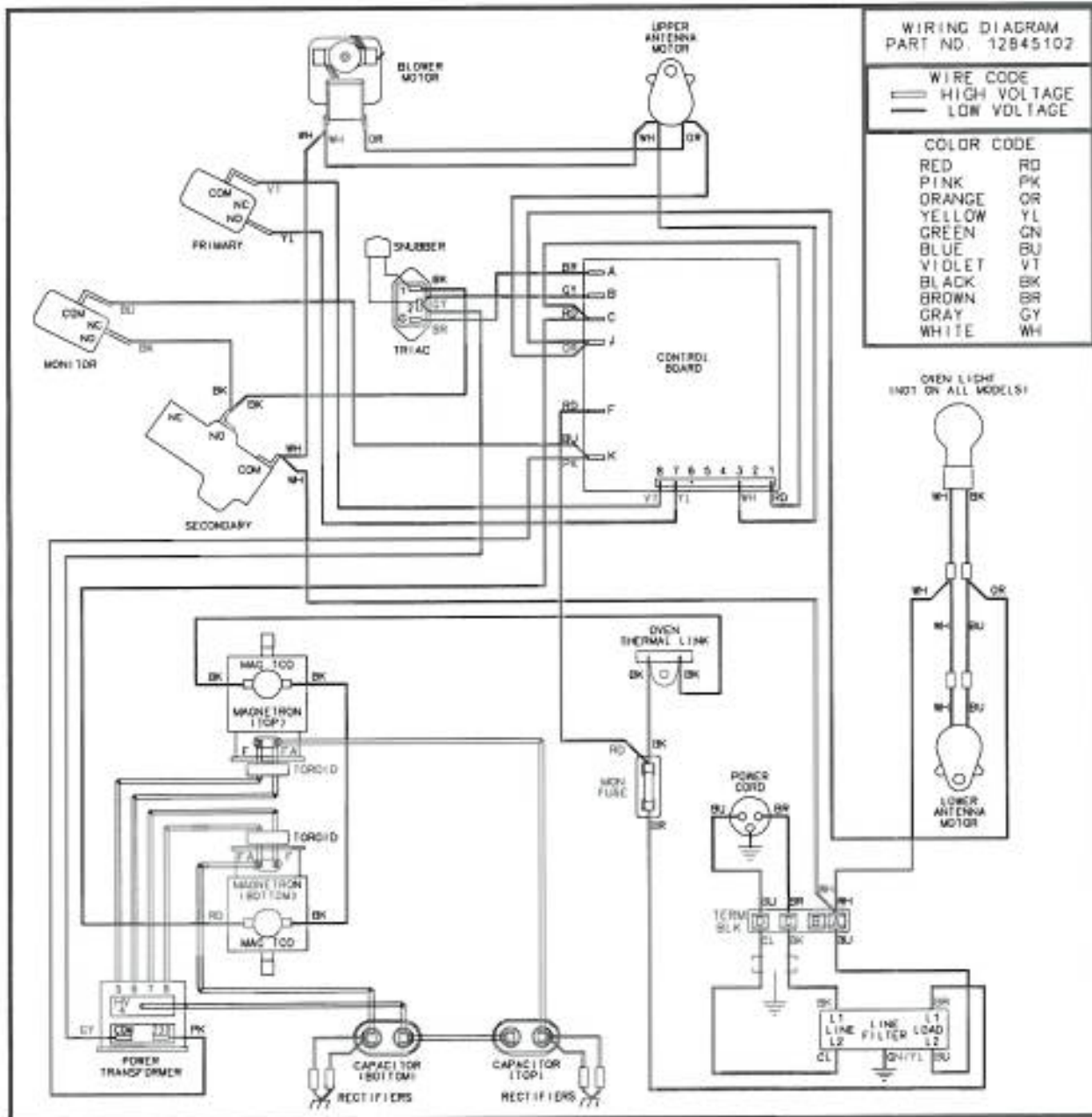

12845102

HDC5142 P1331215M
 DEC14E2 P1331217M
 HDC5182 P1331219M
 DEC18E2 P1331221M

UHDC5142 P1331216M
 UC14E2 P1331218M
 UHDC5182 P1331220M
 UC18E2 P1331222M

Wiring and Schematic Diagrams



WARNING

To avoid risk of electrical shock, personal injury, or death, disconnect power to oven and discharge capacitor before servicing, unless testing requires power.

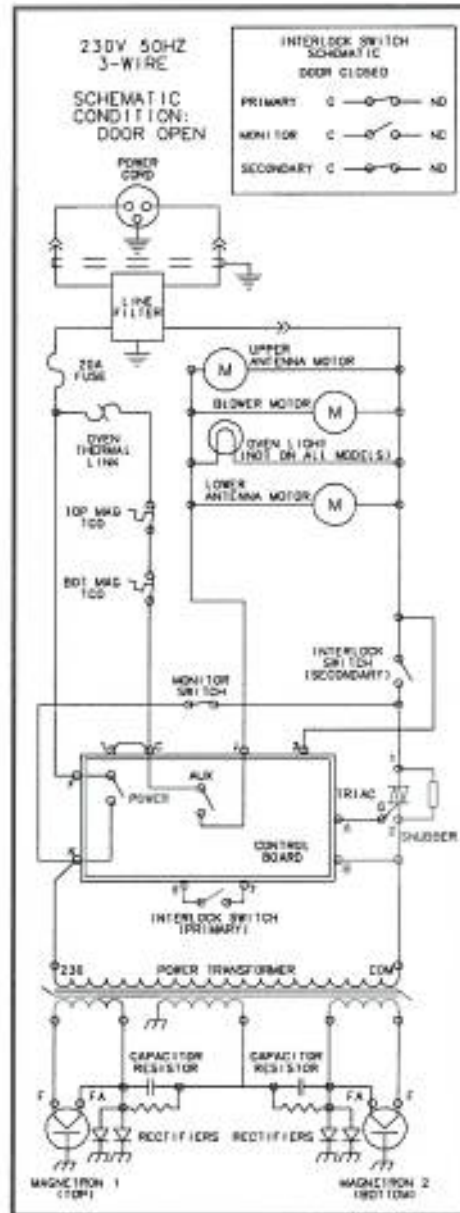

12845102



HDC5142
DEC14E2
HDC5182
DEC18E2

P1331215M
P1331217M
P1331219M
P1331221M

UHDC5142
UC14E2
UHDC5182
UC18E2

P1331216M
P1331218M
P1331220M
P1331222M